

भारतीय गैर न्यायिक
भारत INDIA

रु. 500

FIVE HUNDRED
RUPEES

पाँच सौ रुपये

Rs. 500

सत्यमेव जयते

INDIA NON JUDICIAL



தமிழ்நாடு தமில்நாடு TAMILNADU

09 MAY 2024

Bajaj Finance Limited

AC 094516
J. JAYAKAR
STAMP VENDOR
L. NO. 17/83/1997
ANNA NAGAR, CHENNAI - 600 040.

This Stamp paper forms an integral part of the Debenture Trust Deed (series-289) dated 30th May 2024 executed between Bajaj Finance Limited and Catalyst Trusteeship Limited at Chennai.



For Catalyst Trusteeship Limited

Arune P. V.S.
Authorised Signatory



DEBENTURE TRUST DEED

BETWEEN

BAJAJ FINANCE LIMITED
AS THE ISSUER / COMPANY

AND

CATALYST TRUSTEESHIP LIMITED
AS THE DEBENTURE TRUSTEE

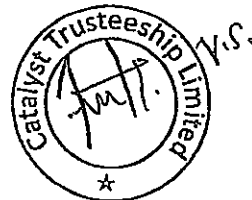
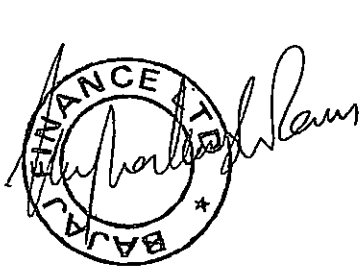

DEBENTURE TRUST DEED

THIS DEBENTURE DEED (hereinafter referred to as the "Deed") is made at Chennai on this day of May 30, 2024.

BY AND BETWEEN

BAJAJ FINANCE LIMITED, a Public Limited Company registered under the Companies Act, 1956, and a Company within the meaning of Section 2(20) of the Companies Act 2013 identified by the CIN L65910MH1987PLC042961 and having its registered office at Akurdi, Pune – 411035 and Corporate Office Ext. at 3rd floor, Panchshil Tech Park, Plot 43/1, 43/2 & 44/2, Viman Nagar, Pune - 411014, hereinafter referred to as the "**Company**" or the "**Issuer**" (which expression shall include its successors and permitted assigns wherever the context or meaning shall so require or permit) of the **ONE PART**;

AND

CATALYST TRUSTEESHIP LIMITED, a Company registered under the Companies Act, 1956, and a Company within the meaning of Section 2(20) of the Companies Act 2013 identified by the CIN. U74999PN1997PLC110262 and having its registered office at GDA House, Plot No. 85, Bhusari Colony (Right), Kothrud, Pune-411038 (hereinafter referred to as the "**Debenture Trustee**" or "**Trustees**" which expression shall unless excluded by or repugnant to the context or meaning thereof include its successors and assigns) of the **OTHER PART**.



The Trustee has been appointed by the Company in accordance with the requirements of the Companies Act, 2013, SEBI (Issue and Listing of Non-Convertible Securities) Regulations, 2021, RBI guidelines and SEBI (Debenture Trustees) Regulations, 1993 along with all amendments thereto.

The Company and the Debenture Trustee are hereinafter individually referred to as "**Party**" and collectively as "**Parties**".

WHEREAS: -

- A) The Company is duly incorporated and validly existing under the laws of India and is engaged, *inter alia*, in the business of providing various financial services and is registered as NBFC under Section 45IA of the Reserve Bank of India Act, 1934. The details of the authorised, issued, subscribed and paid-up share capital of the Company as on 31 March 2024, are as under: -



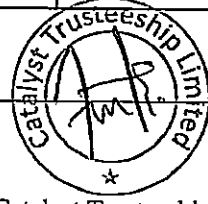

Particulars	Amount (Rs.)
A. Authorized share capital 75,00,00,000 Equity shares of Rs.2/- each	150,00,00,000
B. Paid-up 618,007,991 Equity shares of Rs.2/- each	1,236,015,982
C. Share Premium Account	265,821,461,885

  1
Bajaj Finance Limited
as the Issuer

 V.S.
Catalyst Trusteeship Limited
as the Debenture Trustee

- (I) With a view to meet the Company's requirements for the Purpose (as defined hereinafter), the Company being duly empowered by its Memorandum of Association and Articles of Association, and special resolution passed by the Shareholders at their 36th Annual General Meeting held on 26 July 2023, pursuant to provisions of Section 42 of the Companies Act, 2013, Rule 14 of the Companies (Prospectus and Allotment of Securities) Rules, 2014 and any other applicable provisions of Companies Act 2013, has authorized the Board of Directors of the Company to make offer(s) or invitation(s) to subscribe to secured, redeemable, non-convertible, debentures in one or more series during the period from the conclusion of said Annual General Meeting till the conclusion of next Annual General Meeting of the Company through private placement in conformity with Rules, Regulations and enactments as applicable from time to time, upto total amount not exceeding the borrowing powers approved by the members from time to time including any subsequent approval of the shareholders in this regard.
- (II) The Board of Directors of the Company ('Board') at their meeting held on 20 March 2024 has authorised issue of Secured Redeemable Non-Convertible Debentures on private placement basis upto **Rs. 80,000** Crore in one or more tranches with an authority to Shri Rajeev Jain - Managing Director, Shri Anup Saha - Deputy Managing Director, Shri Sandeep Jain - CFO, and Shri Anand Bagri - Executive Vice- President, Treasury, severally to change the sub limits and also permit interchangeability within the overall limit of Rs. **3,00,000** Crores under Series 289 in one or more tranches, including necessary modifications or amendments as may be deemed appropriate by the Board from time to time.
- (III) The Company intends to issue rated, listed secured redeemable non-convertible debentures aggregating to Rs. **50,000- Crore (Rupees Fifty Thousand Crore)** under Series 289 to be issued in multiple tranches (hereinafter referred to as the "**Debentures**" or "**NCDs**") on private placement in dematerialized form to the Debenture Holder(s), in terms of General Information Document dated May 2024, this Deed and the Transaction Documents (as defined hereinafter).
- (IV) The Special Resolution has been passed, by the Shareholders, through Postal Ballot on 19 March 2024 under Section 180(1) (c) of The Companies Act, 2013, authorizing the Board of Directors of the Company to borrow upto Rs.3,75,000 Crore, over and above the aggregate of paid-up capital of the Company and free reserves, including any subsequent approval of the shareholders in this regard.
- (V) The Special Resolution has been passed, by the Shareholders, through Postal Ballot on 19 March 2024 under Section 180(1)(a) of The Companies Act, 2013, authorizing the Board of Directors of the Company, *inter alia*, for, hypothecating, all or any of the company's assets and properties whether immovable or movable, in favour of the banks / financial institutions /other lenders / debenture trustee / security trustee as may be agreed by the Board of Directors of the Company for the purpose of securing the repayment of any loans / financial assistance, debentures or bonds or other instruments issued to the public and/or on private placement basis and/or in any other manner, subject to maximum of

2

  Bajaj Finance Limited as the Issuer	  Catalyst Trusteeship Limited as the Debenture Trustee
--	--

Rs. 3,75,000 crore (Rupees Three Lakh Seventy Five Thousand crore). Accordingly, the Company pursuant to aforesaid resolutions proposed to allot the Debentures for cash at par basis, in terms of the General Information Document/Key Information Document/Offer Letter/ Prospectus/ Disclosure Document to the subscribers thereof ("**Debenture Holders**" or "**Non-Convertible Debenture Holders**" or "**NCD Holders**").

- B) The Debenture Trustee is registered with the Securities and Exchange Board of India ("**SEBI**") as a debenture trustee under the SEBI (Debenture Trustee) Regulations, 1993 and pursuant to the consent letter dated 23 May 2024 has agreed to act as a debenture trustee, in trust for the benefit of the Debenture Holders for the issuance of the Debentures. The Debenture Trustee and the Company have entered into a debenture trustee agreement dated 29 May 2024, as amended from time to time ("**Debenture Trustee Agreement**") whereby the Company has appointed the Debenture Trustee and the Debenture Trustee has agreed to be appointed as debenture trustee for the benefit of the Debenture Holder(s) and for purposes related thereto, including for holding the security to be created by the Company in favour of the Debenture Trustee to secure the payment and other obligations of the Company in respect of the Debentures. Under the Debenture Trustee Agreement, the Parties have also agreed to execute a debenture trust deed in compliance with the provisions of the Act.
- C) Accordingly, the Debenture Trustee has called upon the Company to execute this Deed being these presents, to issue Non-convertible Redeemable Debentures (NCDs), for an aggregate nominal value of **Rs. 50,000/- (Rupees Fifty Thousand only)** under Series 289 comprising of one or more Tranches under one or more series to be issued on private placement basis under the General Information Document/ Key Information Document and accordingly, these presents shall record the various terms, conditions and stipulations as well as the Company's obligation in respect of the Debentures including Redemption of the Debentures, payment of interest, remuneration of the Trustee and all costs, charges, expenses and other monies in accordance with the terms of the issue, conditions of appointment of Debenture Trustee, creation, maintenance and enforcement of Security, and the Company has agreed to do so in the manner set out hereinafter.
- D) This Deed is divided into the following sections: (i) Part A which sets out the terms of Debentures, which are standard in nature or are terms stipulated pursuant to statutory or regulatory requirements; and (ii) Part B which sets out the terms of the Debentures which are specific to this issuance.

NOW THIS DEED WITNESSETH AND IT IS HEREBY MUTUALLY AGREED AND DECLARED BY AND BETWEEN THE PARTIES HERETO AS UNDER:



1. DEFINITIONS AND INTERPRETATION

In these presents, unless there is anything in the subject or context inconsistent therewith, the expressions listed below shall have the following meanings:

1.1 Definitions

- 1.1.1 "**Act**" shall mean the Companies Act, 2013 (to the extent notified and effective) or Companies Act, 1956 (to the extent applicable), as may be amended from time to

3

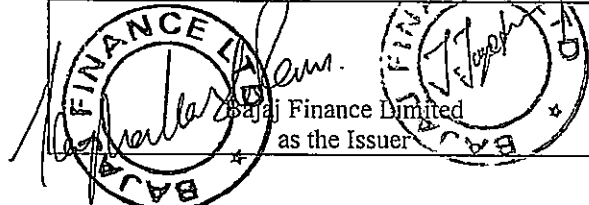
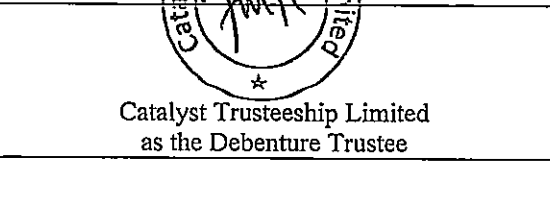

 Finance Limited as the Issuer	 Catalyst Trusteeship Limited as the Debenture Trustee
---	---

- time and shall include any statutory amendment or re-enactment thereof from time to time including but not limited to the rules, circulars, notifications or orders issued thereunder.
- 1.1.2 "Account Bank/ NCD Redemption Account"** shall have the meaning ascribed to the term in Clause 2.2.2 of this Deed.
- 1.1.3 "Applicable Law(s)"** shall mean any statute, law, regulation, notification, ordinance, rule, judgement, rule of law, order, decree, government resolution, clearance, approval, directive, guideline, policy, requirement, or other governmental restriction or any similar form of decision, or determination by, or any interpretation or administration of any of the foregoing by, any statutory or governmental or regulatory authority including without limitation stock exchanges, having jurisdiction over the matter in question, whether in effect as of the date of this Deed or thereafter and in each case as amended.
- 1.1.4 "Board"** shall mean the board of directors of the Company for the time being and from time to time.
- 1.1.5 "Business Day"** shall mean a day (other than a Saturday, Sunday or a Bank holiday) on which money market is functioning in Mumbai and **"Business Days"** shall be construed accordingly.
- 1.1.6 "Debentures"** shall have the meaning ascribed to such term in Recital II hereto.
- 1.1.7 "Debenture Documents"** shall mean all documents entered into/ to be entered into in relation to the issuance of the Debentures and/or the creation of any Security Interest and/or other rights and privileges of the Debenture Holders and the Debenture Trustee including but not limited to the Debenture Trust Deed, Debenture Trustee Appointment Agreement, the Disclosure Document, Deeds of Hypothecation, the security documents, the Disclosure Document/ General Information Document/Key Information Document/Prospectus/ Offer Letter and any other agreement or document mutually agreed by the Debenture Trustee and the Issuer to be a 'Debenture Document'.
- 1.1.8 "Debenture Holder(s)" or "Beneficial Owners(s)"** shall mean the persons who are, for the time being and from time to time, the owners of the Debentures in physical form or electronic (dematerialized) form, and whose names appear in the register of debenture holders(s) or the list of beneficial owner(s)/register of beneficial owners(s) prepared, held and given by the Depository, and **"Beneficial Owner"** means each such person and includes their respective successors/ administrators, transferees and assigns.
- 1.1.9 "Debenture Redemption Reserve"** shall have the meaning under Clause 5.1.9 of this Deed.
- 1.1.10 "Debenture Trustee Agreement"** shall have the meaning ascribed to the term in Recital B.
- 1.1.11 "Deed"** shall mean this debenture trust deed as may be amended, modified, or supplemented from time to time.

 <p>Bajaj Finance Limited as the Issuer</p>	4	 <p>Catalyst Trusteeship Limited as the Debenture Trustee</p>
--	---	---

- 1.1.12 "Deed of Hypothecation"** shall mean the deeds of hypothecation which shall be executed by the Issuer in favour of the Debenture Trustee, from time to time, for creation of Security Interest on the Hypothecated Property for the benefit of the Debenture Holders.
- 1.1.13 "Deemed Date of Allotment"** shall mean the date of allotment as set out in the General Information Document/Key Information Document/ Prospectus/ Disclosure Document/ Offer Letter and Clause 10.4 of this Deed.
- 1.1.14 "Depository"** shall mean the depository with whom the Company has made arrangements for dematerializing the Debentures namely, National Securities Depository Limited (NSDL) and/or Central Depository Services (India) Limited (CDSL).
- 1.1.15 "Disclosure Document/ General Information Document/Key Information Document/ Prospectus/ Offer Letter/ Information Memorandum"** shall mean General Information Document / Key Information Document/ disclosure document/ prospectus/offer document/ private placement memorandum dated ___ May 2024, which sets out the key terms and conditions upon which the Debentures are proposed to be issued/ have been issued by the Company to the Debenture Holder(s) and shall mean disclosure document(s) issued in respect of the Debentures, from time to time.
- 1.1.16 "Event(s) of Default"** shall mean any event or circumstance as described in Clause 4 of this Deed.
- 1.1.17 "Financial Covenants and Conditions"** shall mean the covenants and conditions on the part of the Company to be observed and performed as set out in the General Information Document/Key Information Document be modified in accordance with these presents.
- 1.1.18 "Final Redemption Date"** shall mean the date when the nominal amount of the outstanding Debenture/s is to be paid by the Company to the Debenture Holder(s) together with all the accrued coupon, further interest, and all other monies whatsoever due and payable by the Company in respect of the Debentures.
- 1.1.19 "Government" or "Governmental Authority"** shall include president of India, the government of India, governor or the government of any state in India or any ministry, department, board, authority, instrumentality, agency, corporation or commission semi-governmental or judicial or quasi-judicial or administrative entity, any self-regulatory organization, under the direct or indirect control of the government of India.
- 1.1.20 "Initial Contribution"** shall have the meaning ascribed to the term in Clause 3.2.1.
- 1.1.21 "Inter Creditor Agreement" or "ICA"** shall mean an agreement entered under the directions issued by RBI described as the RBI (Prudential Framework for Resolution of Stressed Assets) Directions, 2019 providing a framework for early recognition, reporting and time bound resolution of stressed assets on June 7, 2019 as amended from time to time read with the SEBI operational circular for Debenture Trustees bearing no. SEBI/HO/DDHS/P/CIR/2023/50 dated March 31, 2023 updated on 6 July 2023 prescribing the procedure to be followed by debenture trustees in case of

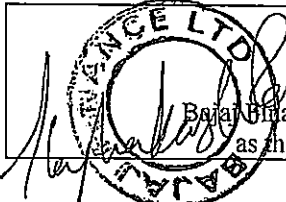
5

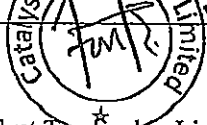
 <p>Bajaj Finance Limited as the Issuer</p>	 <p>Bajaj Finance Limited as the Issuer</p>	 <p>Catalyst Trusteeship Limited as the Debenture Trustee</p>
--	--	---

'Default' by issuers of listed debt securities including seeking consent from the Debenture Holder(s) for enforcement of security and/or entering into an inter-creditor agreement, as amended from time to time.

1.1.22 "Issue Closing Date" shall mean the date of closure of the Issue of Debentures, as set out in the Disclosure Documents.

1.1.23 "Material Adverse Effect" shall mean an event, circumstance, occurrence or condition which has caused, as of any date of determination, or could be expected to cause a material adverse effect or a material adverse change in the opinion of Debenture Trustee, acting on/with Majority Debenture Holders' instructions / approval on:

- a. the business, operations, property, assets, condition (financial or otherwise) or prospects of the Company; or
- b. the ability of the Company to perform its obligations under any Transaction Documents or affects the validity of the Transaction Documents or any other related document to which Company is or will be a party; or
- c. the legality or validity or enforceability of the Transaction Documents or any other related document or the rights or remedies of Debenture Holder(s) /Beneficial Owner(s) thereunder; or
- d. legality or validity or enforceability of, or the effectiveness or ranking of any Security granted or purporting to be granted pursuant to any of, the Security Documents; or
- e. any other effect or change which adversely affects the interest of the Debenture Holder(s) /Beneficial Owner(s) or the Debenture Trustee.

1.1.24 "Majority Debenture Holder(s)/Beneficial Owner(s)" shall at any time mean such number of Debenture Holder(s)/Beneficial Owner(s) holding more than 50% of the then outstanding Debentures. For sake of clarity, it is herein clarified that the 'majority' shall be determined as majority of debenture holders under each respective International Securities Identification Number ("ISIN").

1.1.25 "Hypothecated Property" means all book debts and receivables of the Company more particularly described in **FIRST SCHEDULE** hereunder hypothecated and charged by way of security; in terms of the provisions of Clause 11 hereof.

1.1.26 "SEBI Master Circular" shall mean the SEBI master circular on issue and listing on Non-Convertible Securities, Securitised Debt Instruments, Security Receipts, Municipal Debt Securities and Commercial Paper dated 22 May 2024, as amended from time to time, issued by Securities Exchange Board of India.

1.1.27 "Part A" shall mean all the text, clauses, sub-clauses which have been included in the Part A of this Deed. The Part A are statutory clauses, sub-clauses /standard information pertaining to the Debentures.

1.1.28 "Part B" shall mean all the text, clauses, sub-clauses which have been included in the Part B of this Deed containing details specific to the Debentures, as amended from time to time.

1.1.29 "Permitted Security Interest" shall mean any exclusive security interest created for the benefit of certain governmental, regulatory or statutory authorities, or any entity

6

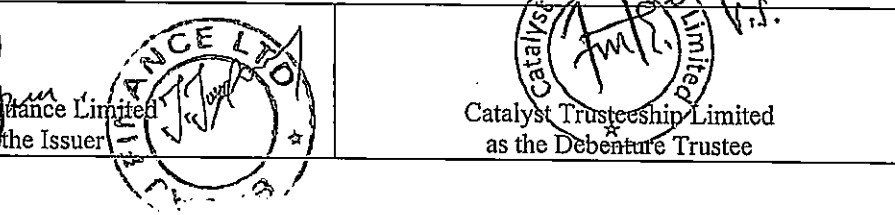
 Bajaj Finance Limited as the Issuer	 Catalyst Trusteeship Limited as the Debenture Trustee
---	--

incorporated by a statute, and treatment to such security interest during the regular course of business of the company.

1.1.30 "Purpose" shall mean the purpose for which the Debentures have been issued by the Company, as stated in General Information Document/Key Information Document/ Prospectus/ Disclosure Document/ Offer Letter.

1.1.31 "Quarter" shall mean the period of three months commencing on the first day of January, April, July or October of a calendar year.

1.1.32 "RBI" means the Reserve Bank of India.

1.1.33 "Receiver" shall mean the receiver appointed in relation to any of the Secured Assets.

1.1.34 "Recovery Expense Fund" shall mean fund contributed by the Company towards creation of a recovery expense fund as required to be created in terms of the Chapter IV of SEBI Master Circular for Debenture Trustees.

1.1.35 "Repayment" shall include "**Redemption**" and *vice versa* and the expressions repaid, repayable, repayment, redeemed, redeemable and redemption shall be construed accordingly.

1.1.36 "Record Date" shall mean the date as set out in the General Information Document/Key Information Document/ Prospectus / Disclosure Document/ Offer Letter and Clause 10.12 of this Deed.

1.1.37 "Redemption Date" shall mean each date on which the Debentures are required to be redeemed, as set out in the General Information Document/Key Information Document/ Disclosure Document / Prospectus / Offer Letter and Clause 10.11 of this Deed.

1.1.38 "SEBI" shall have the meaning ascribed to such term in Recital B.

1.1.39 "SEBI Master Circular for Debenture Trustees" shall mean the SEBI circular bearing reference number SEBI/HO/DDHS-PoD3/P/CIR/2024/46 dated May 16, 2024, as amended from time to time.

1.1.40 "SEBI Guidelines" shall include the following guideline(s)/regulation(s) (as amended from time to time) issued by SEBI and any other guidelines/regulations that may be issued/amended by SEBI from time to time:

SEBI (Debenture Trustee) Regulations, 1993;

SEBI (Issue and Listing of Non-Convertible Securities) Regulations, 2021; and

SEBI (Listing Obligations and Disclosure Requirements) Regulations, 2015.

1.1.41 "Secured Obligations" shall mean all obligations at any time due, owing or incurred by the Company to the Debenture Trustee or the Debenture Holders, as the case may be, in respect of the Debentures and shall include

7

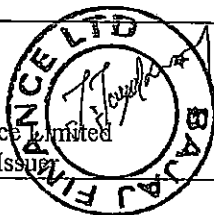
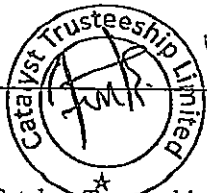
 Bajaj Finance Limited as the Issuer	 Bajaj Finance Limited as the Issuer	 Catalyst Trusteeship Limited as the Debenture Trustee
---	---	--

- (i) the obligation to redeem the Debentures in terms thereof including payment of coupon/interest, default interest, penal interest, any outstanding remuneration of the Debenture Trustee and all fees, costs, charges and expenses payable to the Debenture Trustee/Debenture Holder(s) and other monies payable by the Company in respect of the Debentures under the Transaction Documents;
- (ii) any and all sums advanced by the Debenture Trustee in order to preserve the Security created / to be created by the Company in relation to the Debentures;
- (iii) in the event of any proceedings for the collection and/or enforcement of the obligations of the Company in respect of the Debentures, after an Event of Default shall have occurred, the expenses of taking possession, holding, preparing for sale, selling or otherwise disposing of or realizing the Security or any part thereof, created / to be created by the Company, and / or of any exercise of the Debenture Trustee of its rights under the relevant Transaction Documents, together with legal fees and court costs in relation thereto.

1.1.42 "Security" shall mean the Security Interest required to be created over the Secured Assets to secure the Debentures, as set out in this Deed.

1.1.43 "Secured Assets" shall mean the assets (whether tangible or movable) as more particularly set out in Clause 11.2 of this Deed over which Security Interest is required to be created under the Transaction Documents in favour of Debenture Trustee, for the benefit of Debenture Holders for the Repayment of the Secured Obligations.

1.1.44 "Security Coverage Ratio" or "Asset Cover" shall mean "Asset Cover" or "Security Cover" shall mean the total value of the Hypothecated Property at any given time until the Final Redemption Date divided by the Outstanding Amounts at the same point of time and the same shall be maintained in accordance with the General Information Document / Prospectus/Offer Letter/ Disclosure Documents but in no event shall be less than 1.00 time as may be modified from time to time.

1.1.45 "Security Interest" shall mean hypothecation.

1.1.46 "Security Documents" shall mean all such documents as may be required for creating and perfecting the Security Interest as may be required to be created in terms of the Transaction Documents, in favour of the Debenture Trustee for the benefit of the Debenture Holder(s) (and their successors and assigns from time to time).

1.1.47 "Special Majority" shall at any time mean such number of Debenture Holder(s)/Beneficial Owner(s) holding more than 75% in value of the then outstanding Debentures and 60% of the Debenture Holder(s) / Beneficial Owner(s) in numbers. For sake of clarity, it is clarified that the Special Majority shall be determined under each respective ISIN.

1.1.48 "Special Resolution" shall mean a resolution passed by the Debenture Holder(s)/Beneficial Owner(s), holding not less than three-fourth in value of outstanding Debentures, at a duly convened meeting of the Debenture Holder(s) and shall include only valid votes cast by members voting in person or proxy.

8

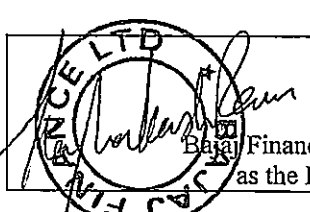
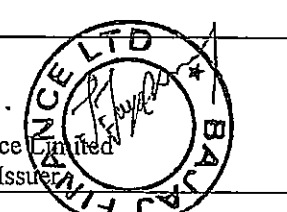
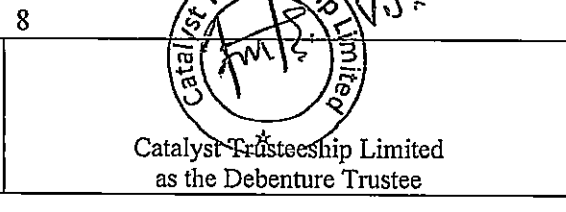
 <p>Bajaj Finance Limited as the Issuer</p>	 <p>Bajaj Finance Limited as the Issuer</p>	 <p>Catalyst Trusteeship Limited as the Debenture Trustee</p>
--	--	---

- 1.1.49 "Tax" or "Taxes"** means any present or future tax, levy, duty, charge, fees, turnover tax, transaction tax, stamp tax or other charge of a similar nature (including any penalty or interest payable on account of any failure to pay or delay in paying the same), now or hereafter imposed by law by any Governmental Authority and as may be applicable in relation to the payment obligations of the Company under this Deed.
- 1.1.50 "Tax Deduction"** means a deduction for or on account of Tax from a payment under a Transaction Document.
- 1.1.51 "Tenor"** shall mean the period from the Deemed Date of Allotment till the Redemption date.
- 1.1.52 "Transaction Documents"** shall mean the documents executed in relation to the issue of the Debentures and the creation of the Security Interest in relation to the Debentures including but not limited to the General Information Document/Key Information Document/Disclosure Documents/Prospectus/ Offer Document (if any), the letters issued by the rating agency, Debenture Trustee Agreement, this Deed, Security Documents, necessary powers of attorney (if any) and such other documents as designated as such by the Debenture Trustee.

1.2 Interpretation

- 1.2.1** Words denoting singular number only shall include plural number and *vice versa*.
- 1.2.2** Words denoting one gender only shall include the other gender.
- 1.2.3** Words denoting persons only shall include companies and bodies corporate.
- 1.2.4** Any reference in this Deed, to this Deed or any other document shall be construed, without limitation, as a reference to this Deed or, as the case may be, such other document, in each case as the same may have been, or may from time to time be, amended, varied, novated, acceded to or supplemented and any reference to any statutory provision shall include such provision and any regulations, order or rule made thereunder and any statutory re-enactment, modification or replacement thereof.
- 1.2.5** All references in these presents to Schedules, Clauses, Sub-Clauses, Paragraphs or Sub-paragraphs shall be construed as reference respectively to the Schedules, Clauses, Sub-clauses, Paragraphs and Sub-paragraphs of these presents.
- 1.2.6** The recitals and schedules shall constitute an integral and operative part of this Deed. The provisions contained in the Schedules hereunder written shall have effect in this manner as if they were specifically herein set forth.
- 1.2.7** No provision of this Deed shall be interpreted in favour of or against any Party by reason of the extent to which such Party or its counsel participated in the drafting hereof or by reason of the extent to which any such provision is inconsistent with any prior draft hereof.
- 1.2.8** In the event of any disagreement between the Company and the Debenture Trustee regarding the materiality or reasonableness of any event under the Transaction Documents, the Debenture Trustee (acting on the instructions of the Debenture

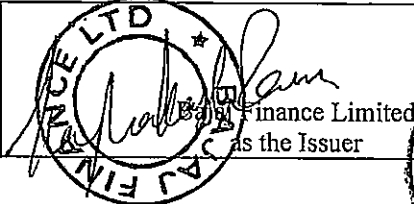
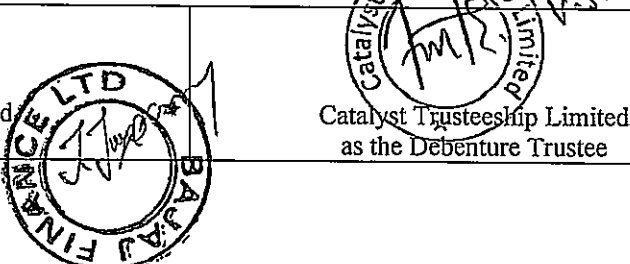

9

 <p>Finance Limited as the Issuer</p>	 <p>Catalyst Trusteeship Limited as the Debenture Trustee</p>	
--	---	--

Holder(s)) shall be entitled at their discretion, to determine such materiality or reasonableness, which shall be binding on the Company without prejudice to any rights that may be available to the Company under the Applicable Law.

- 1.2.9** All references to the consent or discretion or agreement or waivers or any actions of the Debenture Trustee under this Deed or any other Transaction Documents shall mean the Debenture Trustee acting in accordance with the consent of the Majority Debenture Holders unless specifically provided otherwise.
- 1.2.10** The obligations of the Company shall be governed by the provisions contained in the General Information Document/Key Information Document/ Prospectus/ Offer Letter and these presents, and in the event of there being any inconsistency or repugnancy between the provisions contained in the General Information Document and these presents, the provisions contained in the General Information Document shall prevail over this Deed for all purposes and to all intents.

10

 BNP Paribas Finance Limited as the Issuer	 Catalyst Trusteeship Limited as the Debenture Trustee
---	--

PART – A OF THE DEBENTURE TRUST DEED

2. AMOUNT OF DEBENTURES AND COVENANT TO PAY PRINCIPAL AND INTEREST

2.1 Amount of Debentures:

The Debentures are being issued and allotted, on private placement basis, in dematerialized form for cash at par in terms of this Deed for an aggregate nominal value amount of Rs. **50,000/- Crore** (Rupees **Fifty Thousand** Crore only) under Series 289 to be issued in multiple tranches, to the Debenture Holder(s)/Beneficial Owner(s), as the case may be. The Company shall utilise the monies received from the subscription of the Debentures solely towards the Purpose viz., **for general business purpose of the Company including various financing activities, to repay existing loans, investments for liquidity and statutory requirements, capital expenditure and working capital requirements.**

2.2 Covenant to Pay Principal and Interest:

2.2.1 The Company covenants with the Trustee that it shall pay to the Debenture Holder(s)/Beneficial Owner(s) the principal amount of the Debentures together with redemption premium, if any, on the Redemption Dates and shall also pay interest (inclusive of penal interest where applicable) on the Debentures in accordance with Clause 10.11 of this Deed and the General Information Document/ Disclosure Document/ Prospectus/ Offer Letter.

Provided that if so called upon by the Trustee, the Company shall make payments as aforesaid to or to the order of or for the account of the Trustee and such payment shall be deemed to be in satisfaction of the aforesaid covenant of the Company to make such payments to the Debenture Holder(s)/Beneficial Owner(s). Such payments shall be passed on to the Debenture Holder(s)/Beneficial Owner(s), subject to the appropriation in the order of preference mentioned in Clause 10.15 of this Deed.

2.2.2 The Company shall provide to the Debenture Trustee the details of the bank account as mentioned below from which it proposes to pay any Redemption Amount and interest to the relevant Debenture Holders.

Bank account Number	: 00070350000180
Name of Bank	: HDFC Bank Limited("Account Bank")
IFSC Code	: HDFC0000007
HDFC0000007	: 5th Floor, "Marathon" Bldg21/6, Bund Garden Road, Opp. Hotel Sun N Sand, Pune-411001
Contact Person	: Rahul Mahajan
E-mail Id	: rahul.mahajan6@hdfcbank.com

2.2.3 The Company shall, at all times till the Final Settlement Date, maintain the NCD Redemption Account, from which it proposes to pay all the outstanding Secured Obligations. The Company agrees and acknowledges that they shall intimate any change in the NCD Redemption Account to the Debenture Trustee within one working day.

11

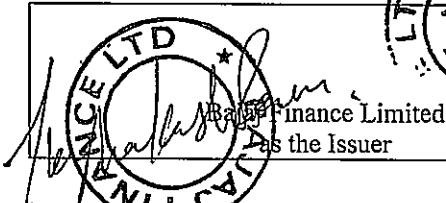
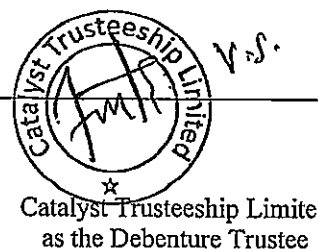
 Catalyst Finance Limited as the Issuer	 Catalyst Trusteeship Limited as the Debenture Trustee
--	--

2.2.4 The Company further acknowledges, agrees, that the Debenture trustee is authorised to seek redemption and Coupon payment related details and information from the Account Bank in terms of the extant SEBI Laws.

2.2.5 The Company covenants with the Debenture Trustee that it shall comply with all its obligations under this Deed and pay and repay all the monies payable by the Company (including any applicable default interest, fees and costs and expenses) to the Debenture Trustee and the Debenture Holder(s) pursuant to the terms of this Deed.

2.3 INTEREST

2.3.1 The Debenture Holder(s)/Beneficial Owners(s) shall be paid interest in accordance with the provisions under Clause 10.09 of this Deed and the Shelf Disclosure Document/Disclosure Document/Prospectus/ Offer Letter.

2.3.2 Interest and all other charges shall accrue from day to day and shall be computed on the basis of actual number of days elapsed, in a year of 365 days year or 366 days (in case of leap year), as the case may be.

2.3.3 Any payments to be made to the Debenture Holder(s)/Beneficial Owner(s), including payment of interest, payment upon Redemption, shall be made by the Company using the services of National Automated Clearing House (NACH), Real Time Gross Settlement (RTGS), direct credit or National Electronic Fund Transfer (NEFT) or any other permitted electronic method as offered by Debenture Holder(s) / Beneficial Owner(s) into such bank account of a Debenture Holder/Beneficial Owner as may be notified to the Company by such Debenture Holder/Beneficial Owner or the Trustee at the time of applying to the Debentures or as may be notified to the Trustee, subsequently through a valid communication channel.

2.4 FORM OF THE DEBENTURES

2.4.1 The Debentures, shall be issued in dematerialized form by the Company by following the procedure stipulated for issuance of the Debentures in demat form, as more particularly described in the **Second Schedule** hereunder written as per the guidelines issued by the Depository from time to time.

2.4.2 The principal amount of the Debentures, together with redemption premium, interest due, if any, (inclusive of penal interest where applicable) and all other monies hereby secured shall, as between the holders of the Debentures, *inter se rank pari passu* without any preference or priority whatsoever on account of date of issue or allotment or otherwise.

2.4.3 The Debenture Holder(s)/Beneficial Owner(s) will be entitled to their Debentures free from equities or cross claims by the Company against the original or any intermediate holders thereof.

2.4.4 The Company has entered into depository arrangements with the Depository for the issue of the Debentures in dematerialized form.

2.5 ISSUANCE OF DEBENTURE

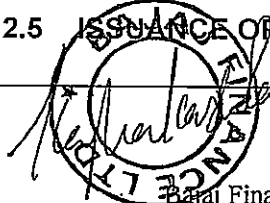
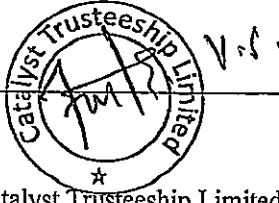
 Rajiv Mehta as the Issuer	12	 Catalyst Trusteeship Limited as the Debenture Trustee
---	----	--

The Company shall immediately on allotment of Debentures in Dematerialized Form, take reasonable steps to credit the beneficiary account of the Beneficial Owner(s) with the Depository Participant as mentioned in the application form, with the number of Debentures allotted within a period of two days from the date of allotment of debentures and shall also follow the procedure laid down by SEBI Master Circular dated 16 May 2024, as updated time to time.

2.6 TRANSFER OF DEBENTURES

The Debentures shall be transferable and transmittable in the same manner and to the same extent and be subject to the same restrictions and limitations as in the case of the equity shares of the Company.

The provisions relating to transfer and transmission in respect of the shares as provided in the Articles of Association of the Company shall apply, *mutatis mutandis*, to the Debentures. Transfer of Debentures in dematerialized form would be in accordance with the rules/procedures as prescribed by the Depository.

2.7 SURRENDER OF DEBENTURES ON PAYMENT

For payment to the Beneficial Owner(s) in full discharge of all principal moneys and interests due upon their Debentures, the Company shall make the payment of principal amount to the Beneficial Owner(s) of Debentures or to any subsequent transferee who are entitled to receive the payment on the due date of Redemption on receipt of the necessary corporate debit action from the Debenture Holder.

2.8 FAILURE TO SURRENDER THE DEBENTURES/ DEBENTURE CERTIFICATES

2.8.1 In the event of the Beneficial Owner(s) failing to undertake necessary corporate debit action, in respect of any Debentures which the Company is ready to pay or satisfy in accordance with the terms of these presents, to the Company, within thirty days after the Final Redemption Date, the Company shall be at liberty to deposit in a scheduled bank in the name of the Trustee in an account, which shall be operated by the Trustee for the purpose, an amount equal to the amount due to such Beneficial Owner(s) in respect of such Debentures and upon such deposit being made the Debentures which the Company is ready to pay or satisfy as aforesaid shall be deemed to have been paid off or satisfied in accordance with the provisions hereof.

2.8.2 After provision for payment and satisfaction of the Debentures is made by the deposit in a scheduled bank as aforesaid, the Trustee may invest the same in any of the investments herein authorised.

2.9 LISTING AND CREDIT RATING

2.9.1 The Company shall list the Debentures on the wholesale debt market segment of BSE Ltd. ("BSE") and in this respect the Company has submitted / is in the process of submitting the details required as per Schedule I of SEBI (Issue and Listing of Non-Convertible Securities) Regulations, 2021 and all applicable laws or guidelines in this regard as amended from time to time (hereinafter referred to as "Non -Convertible Securities Regulations") to the BSE for the purpose of listing the Debentures on its wholesale debt market segment.

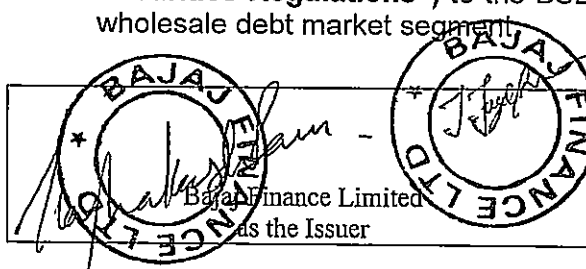
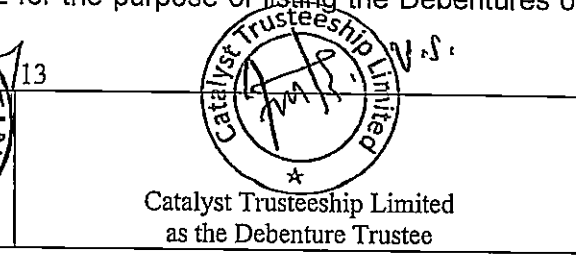
 <p>BAJAJ FINANCE LTD as the Issuer</p>	<p>13</p>  <p>Catalyst Trusteeship Limited as the Debenture Trustee</p>
--	---

2.9.2 The Company shall take all steps for making the listing application to the recognized stock exchange and shall receive approval from the stock exchange for the listing of Debentures, within the timelines specified in the extant SEBI regulations read with the circulars, as may be amended from time to time viz., within 3 Business Days of the Issue Closing Date. The Stock Exchange(s) shall list the Debentures only upon receipt of a due diligence certificate as per format specified by SEBI, from Debenture Trustee confirming creation of charge and execution of the Debenture Trust Deed. In case of delay in listing of the Debentures (issued on private placement basis) beyond the timelines specified above, the Company will pay penal interest, to the Debenture Holders, of at least 1.00% p.a. over the coupon rate stated in Clause 10.10 hereof from the Deemed Date of Allotment until the listing of such Debentures on the entire outstanding amount pertaining to the Debentures.

2.9.3 The Company undertakes to comply with the SEBI (Listing Obligations and Disclosure Requirements), 2015, the Act and other Applicable Laws on a continuous basis. All expenses, costs, charges, incurred for the purpose of listing of the Debentures, as also for making the offer for sale of the Debentures shall be borne and paid by the Company.

2.9.4 The Debentures are rated as:

- (a) "Crisil AAA/Stable" by CRISIL Limited vide letter dated 27th May 2024, "IND AAA/Stable" by India Ratings & Research vide letter dated 17th May 2024, "Care AAA/Stable" by Care Ratings Limited vide letter dated 15th May 2024 and "ICRA AAA/Stable" by ICRA Limited vide letter dated 3rd May 2024. The rating indicates high degree of safety with regard to timely payment of financial obligations.

The Company agrees that the credit rating shall be reviewed on an annual basis, by a credit rating agency registered with SEBI. Any revision in rating shall be promptly intimated to the Debenture Trustee.



In the event there is any downward revision in the credit rating, the terms of the issue shall be revised in the matter as stipulated in the General Information Document / Shelf Disclosure Document/Disclosure Document/Prospectus/ Offer Letter.

2.10 CONDITIONS PRECEDENT, CONDITIONS SUBSEQUENT AND FINANCIAL COVENANTS AND CONDITIONS

The conditions precedent, conditions subsequent and other Financial Covenants and Conditions specified in Clause 10 of this Deed, shall be binding on the Company and the Debenture Holder(s) and all persons claiming by, through or under it and shall ensure to the benefit of the Trustee and all persons claiming by, through or under them. The Trustee shall be entitled to enforce the obligations of the Company under or pursuant to the conditions precedent, conditions subsequent and other Financial Covenants and Conditions specified in Clause 10 of this Deed as if the same were set out and contained in these presents.

3. APPOINTMENT, RETIREMENT, RIGHTS, AND DUTIES OF THE TRUSTEE

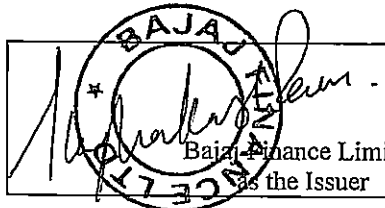
3.1 Appointment of Trustee

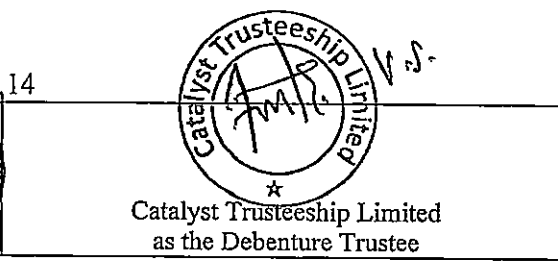
  ¹⁴ 

BAJAJ Finance Limited
as the Issuer

Catalyst Trusteeship Limited
as the Debenture Trustee

The Company has appointed the Debenture Trustee as trustee for the Debenture Holder(s) pursuant to the Debenture Trustee Agreement and has also submitted the consents/documents as elaborated in the Debenture Trustee Agreement. The Company appoints Catalyst Trusteeship Limited as the Trustee, and the Trustee agrees to act as trustee for the benefit of the Debenture Holder(s)/Beneficial Owners(s) and their successors, transferees and assigns under the trust HEREUNDER created pursuant to Clause 3.2 below and in such trust capacity, the Trustee agrees and is authorised:

- (a) to execute and deliver this Deed, all other Transaction Documents and all other documents, deeds, instruments, certificates and agreements, contemplated by this Deed or the other Transaction Documents which are to be executed and delivered by the Trustee or as the Trustee shall deem advisable and in the best interests of the Debenture Holder(s)/Beneficial Owners(s);
- (b) to take whatever action as shall be required to be taken by the Trustee in accordance with the Transaction Documents, and subject to the terms and provisions of this Deed and any other Transaction Documents, to exercise its rights and perform its duties and obligations under each of the documents, deeds, agreements, instruments and certificates referred to in this clause (a) above in such documents, agreements, instruments and certificates; and
- (c) subject to the terms and provisions of this Deed and the other Transaction Documents, to take such other action in connection with the foregoing as the Debenture Holder(s) may from time to time direct.

PROVIDED that before initiating any action or exercising any right or performing any duty under this Deed or any Transaction Documents, the Trustee shall only upon receipt of Majority Debenture Holder(s) instructions/approval initiate any action or exercise its rights and perform its duties and obligations under each of the documents, agreements, instruments and certificates referred in these presents.

3.2 Declaration of Trust by the Trustee

3.2.1 The Company hereby settles in trust with the Debenture Trustee, a sum of Rs.1,000/- (Rupees One Thousand only). The Trustee hereby declares and confirms that it has, accepted the above sum of Rupees One Thousand only) in trust declared and settled and kept apart the sum being the initial corpus (hereinafter referred to as the "Initial Contribution") of the trust created in terms of this Deed, to have and hold the same for the benefit of the Debenture Holders on such terms as set out herein, together with all additions or accretions thereto including the investments representing the same, subject to the powers, provisions, agreements and declarations herein contained.

3.2.2 The Trustee hereby declares that in relation to the Debenture Holder(s), it shall, as the case may be hold:

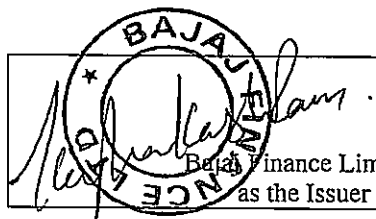
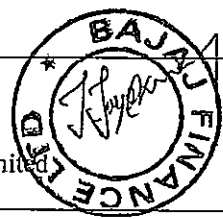
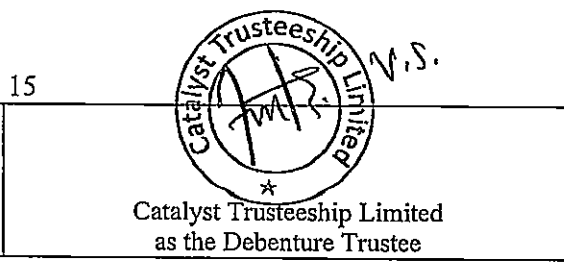
 <p>BAJAJ FINANCE LIMITED as the Issuer</p>	 <p>BAJAJ FINANCE LIMITED</p>	<p>15</p>  <p>Catalyst Trusteeship Limited as the Debenture Trustee</p>
--	--	---

- (a) the Initial Contribution;
- (b) the Security created hereunder and under the other Transaction Documents;
- (c) all sums received by it under this Deed (save for any sums received solely for its own account); and
- (d) all monies received by it out of, whether prior to or as a result of enforcement of the Security created hereunder or the exercise of rights and remedies under this Deed,

upon trust and for the benefit of the Debenture Holder(s)/Beneficial Owner(s) and subject to the powers and provisions hereinafter declared and contained and concerning the same, for due payment and discharge of the Secured Obligations.

3.2.3 The Trustee declares that save and except as contemplated under this Deed, it shall not revoke the trust hereby declared till whole of the Secured Obligations is irrevocably discharged and paid in full by the Company to the Debenture Holder/Beneficial Owner and the Trustee under the Transaction Documents.

3.3 Trustee Remuneration

3.3.1 The Company shall pay to the Trustee remuneration as mentioned in the letter dated 23rd May, 2024, as may be amended or supplemented from time to time, for their services to act as Debenture Trustee in addition to all legal, travelling and other costs, charges and expenses which the Debenture Trustee or their officers, employees or agents may incur in relation to execution of the trust hereof and all other documents pertaining to Debentures and the remuneration shall continue to be payable until the Debenture Trustee hereof shall be finally discharged and whether or not a receiver or a manager shall have been appointed or the trust hereof shall be in course of administration by or under the direction of the court. The Company shall promptly pay, and in any event before any interest or penalty becomes payable, the fees, duty, Taxes and charges of any nature whatsoever payable in connection with the entry into, registration, performance, enforcement or admissibility in evidence of this Deed and/or any such amendment, supplement or waiver.

3.3.2 Arrears of installments of annual service charges, if any, and/ or delay in reimbursement of cost, charges and expenses, after completion of 45 (Forty-Five) days from the date of invoice generated, shall carry interest at the rate of 16% (Sixteen Percent) per annum or under Micro, Small and Medium Enterprises Development Act, 2006, whichever is lower, from the date of such non-payment till the date of actual payment, which shall be payable on the footing of compound interest with quarterly rests..

3.3.3 The Company shall provide upfront to the Trustee all legal, travelling, conveyance and other costs, charges and expenses to be incurred by them, their officers, employees, advisors, experts, consultants or their agents in connection with execution of these presents including costs, charges, expenses of and incidental to the approval and execution of these presents and all other documents affecting the Security herein and the Company hereby agrees to indemnify the Trustee against all actions, proceedings, costs, charges, expenses, claims and demands whatsoever which may be brought or made against or incurred by them in respect of any matter or thing done or omitted to be done without their wilful default in respect of or in relation to the Secured Assets and the Transaction Documents, except when such loss or cost is on account of its own negligence.

16

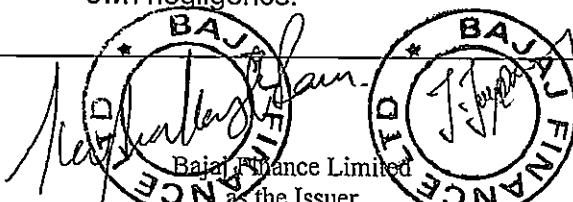
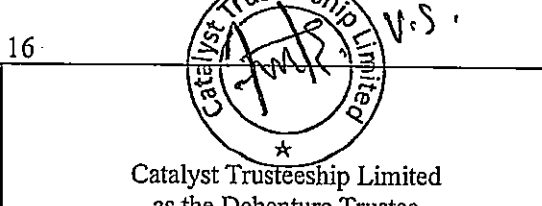
 <p>Bajaj Finance Limited as the Issuer</p>	 <p>Catalyst Trusteeship Limited as the Debenture Trustee</p>
--	---

3.3.4 The Company shall reimburse all sums paid or expenses incurred by the Trustee or any receiver, attorney, agent or other person appointed by the Trustee for all or any of the purposes mentioned in these presents immediately on receipt of a notice of demand from them in this behalf and all such sums shall carry interest at the rate of interest payable on the Debentures from the date, when the same shall have been paid and until such reimbursement, all such sums shall be a charge upon the Secured Assets in priority to the charge securing the Debentures.

3.4 Retirement and Removal of Trustee

3.4.1 The Trustee hereof may, at any time without assigning any reason and without being responsible for any loss or costs occasioned thereof except when such loss or cost is on account of its own negligence, resign/retire as the trustee, provided that the Trustee shall give at least 30 (thirty) days previous notice in writing to the Company.

3.4.2 The Company shall, upon receipt of notice of resignation issued by the Debenture Trustee, take prompt steps to appoint another entity competent to act as trustee for the Debenture Holders in place of the Debenture Trustee with the written consent of the Debenture Holders/Beneficial Owners by a Special Majority. The Trustee shall continue to act as Debenture Trustee until a successor trustee is appointed.

3.4.3 The Company shall appoint an entity registered as a debenture trustee with SEBI under the SEBI (Debenture Trustees) Regulations, 1993 as the debenture trustee. Whenever there shall be more than two Trustees hereof the majority of such Trustee shall be entitled to exercise the powers, authorities and discretions hereby vested in the Trustee.

3.4.4 The Trustee hereof may be removed after giving not less than 30(Thirty) days notice by the Debenture-holder(s)/Beneficial Owner(s) by a Special Resolution duly passed at a meeting of the Debenture Holder(s)/ Beneficial Owner(s) convened in accordance with the provisions set out in the **Third Schedule** hereunder written. The Company shall appoint such person or persons as may be nominated by such resolution as new Trustee for the purpose hereof.

3.4.5 Upon appointment of the successor trustee pursuant to the preceding Clauses 3.4.2 or 3.4.4 above, all references in this Deed to the Debenture Trustee shall, unless repugnant to the context, mean and refer to the successor trustee and the successor trustee shall without any further act or deed succeed to all the powers and authorities and be subject to all duties, liabilities and responsibilities of the Debenture Trustee as if it had been originally appointed as the trustee hereunder.

3.5 Rights and Privileges of Trustee

3.5.1 In addition to the other powers conferred on the Trustee and provisions for their protection, and not by way of limitation or derogation of anything in these presents contained nor of any provisions of the SEBI Act, 1992, Regulations/Circulars made/issued thereunder or any other statute limiting the liability of the Trustee, IT IS EXPRESSLY DECLARED as follows:-

(a) The Trustee may, in relation to these presents, act on the opinion or advice of or any information obtained from any solicitor, counsel, advocate, valuer, surveyor,

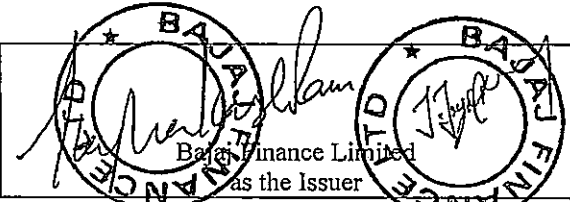
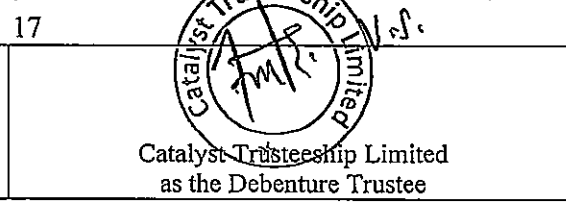

17

 <p>Bajaj Finance Limited as the Issuer</p>	 <p>Catalyst Trusteeship Limited as the Debenture Trustee</p>
--	---

broker, auctioneer, qualified accountant or other expert whether obtained by the Company or by the Trustee or otherwise. Any such advice, opinion or information and any communication passing between the Trustee and their representative or attorney or a receiver appointed by them may be obtained or sent by letter, electronic mail, facsimile, or telephonic message and the Trustee, their representative or attorney or the receiver shall not be liable for acting on any advice, opinion or information purporting to be conveyed by any such letter, electronic mail, facsimile or telephonic message even if the same suffers from inaccuracy, error, genuineness or any other shortcoming which is unknown to the Trustee;

- (b) The Trustee shall be at liberty to accept a certificate signed by any one of the directors of the Company as to any act or matter *prima facie* within the knowledge of the Company as sufficient evidence thereof and a like certificate, that any property or assets are in the opinion of the director so certifying worth a particular sum or suitable for the company's purpose or business as sufficient evidence that it is worth that sum or so suitable and a like certificate to the effect that any particular dealing or transaction or step or thing is in the opinion of the director so certifying expedient as sufficient evidence that it is expedient. However if the Trustee has cause to believe that any certificate received has errors and wrongful facts, then the Trustee shall cause an independent verification of the same;
- (c) The Trustee shall have the right to rely on notices, communications, advertisement or any information on the website of the Company with respect to issue of Debentures;
- (d) The Trustee shall be at liberty to keep these presents and all deeds and other documents of title relating to any of the properties charged/ to be charged to the Trustee at their registered office or elsewhere or if the Trustee so decides with any banker or company whose business includes undertaking the safe custody of documents or with an advocate or firm of solicitors.
- (e) The Trustee may, with the consent of all the Debenture Holder(s)/ Beneficial Owner(s), at any time, waive on such terms and conditions as it shall seem expedient, any breach by the Company of any of the covenants and provisions in these presents contained without prejudice to the rights of the Trustee or the Debenture Holder(s)/ Beneficial Owner(s) in respect of any subsequent breach thereof.
- (f) The Trustee shall, as regards, all trusts, powers, authorities and discretions, have absolute and uncontrolled discretion, in consultation with Debenture-holder(s)/Beneficial Owner(s), as to the exercise thereof and to the mode and time of exercise thereof and in the absence of fraud or gross negligence or misconduct, shall not be responsible for any loss, costs, charges, expenses or inconvenience that may result from the exercise or non-exercise thereof.
- (g) The Trustee hereof being a Company may, in the execution and exercise or all or any of the trusts, powers, authorities and discretion vested in them by these presents act by an officer or officers for the time being of the Trustee and the Trustee may also whenever they think it expedient, delegate by power of attorney or otherwise to any such officer all or any of the trusts, powers,

18

 Bajaj Finance Limited as the Issuer	 Catalyst Trusteeship Limited as the Debenture Trustee
---	---

authorities and discretion vested in them by these presents and any such delegation may be made upon such terms and conditions and subject to such regulations (including power to sub-delegate) as the Trustee may think fit. Any actions of such officers and sub-delegates shall have the same protection as accorded to the Trustee in terms of this Deed. The Trustee shall at all times be responsible for any act/omission on the part of its officers and sub-delegates.

- (h) The Trustee may, in carrying out the trust business, employ and pay any person to transact or concur in transacting any business and do or concur in doing all acts required to be done by the Trustee including the receipt and payment of moneys and shall be entitled to charge and be paid all usual professional and other charges for business transacted and acts done by them in connection with the trust hereof and also their reasonable charges in addition to the expenses incurred by them in connection with matters arising out of or in connection with these presents including matters which might or should have been attended to in person by the Trustee.
- (i) Upon proof being given to the satisfaction of the Trustee that all the Secured Obligations, including the Debentures entitled to the benefit of the trusts hereof together with redemption premium, if any, interest and all other monies payable thereunder have been paid off or satisfied in accordance with the tenor thereof and upon payment of all principal, together with redemption premium, if any, interest, liquidated damages, premium, costs, charges and expenses and other amounts under this Deed or the Debentures or the General information Document / Shelf Disclosure Document / Disclosure Document / Prospectus / Offer Letter and also the payment of all costs, charges and expenses incurred by the Trustee or by any Receiver in relation to these presents (including the remuneration of the Trustee and of any Receiver and all interest thereon) and upon observance and performance of the terms and conditions and covenants herein contained, the Trustee shall at the request and cost of the Company and upon receipt of no dues certificate / confirmation from the Debenture Holders, release, re-assign or re-convey to the Company or as the Company may direct or to such other person entitled thereto the Secured Assets or such part thereof as may remain subject to the security hereby created freed and discharged from the trusts and security created.
- (j) The Trustee shall have full power, in consultation with Debenture Holder(s)/Beneficial Owner(s), to determine all questions and doubts arising in relation to any of the provisions of these presents and every such determination bona fide made (whether or not the same shall relate wholly or partially to the acts or proceedings of the Trustee) shall be conclusive and binding upon all persons interested under these presents.
- (k) The Trustee and its employees shall not be liable for anything whatsoever except for loss or damage caused by their act of negligence, or commission or omission.

3.5.2 To carry on Business

On the happening of any Event of Default and upon the Security constituted becoming enforceable and after the Trustee shall have made entry or taken

19

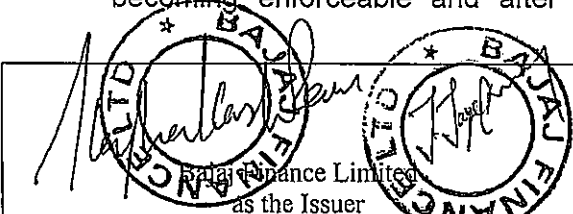
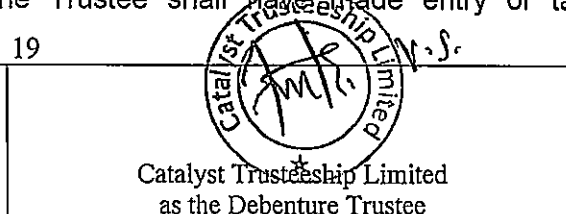
 <p>Baku Finance Limited as the Issuer</p>	 <p>Catalyst Trusteeship Limited as the Debenture Trustee</p>
---	---

possession of the Secured Assets and until the Secured Assets shall be sold, called in, collected or converted under the Power of Sale as mentioned in Clause 8.1 of this Deed, the Trustee may, if they shall think fit so to do but not otherwise, either themselves carry on and manage the business of the Company in and with the Secured Assets or any of them or appoint a Receiver to carry on and manage the same and the Trustee or the Receiver may manage and conduct the same as they shall in their discretion think fit.

The Trustee or the Receiver so appointed may for the purpose of carrying on the said business do all or any of the following acts and things viz.:

- a) employ or remove such experts, officers, agents, managers, clerks, accountants, servants, workmen and others and upon such terms with such salaries, wages or remuneration as the Trustee or the Receiver shall think proper;
- b) insure all or any of the Secured Assets of an insurable nature against loss or damage by fire and against such other risks in such sum or sums as the Trustee or the Receiver shall think fit;
- c) settle, arrange, compromise and submit to arbitration any account, claims, questions or dispute whatsoever which may arise in connection with the said business or the Secured Assets or in any way relating to the security and execute or release other discharges in relation thereto;
- d) bring, take, defend, compromise, submit to arbitration and discontinue any actions, suits or proceedings whatsoever, civil or criminal, in relation to the business or any portion of the Secured Assets;
- e) allow time for payment of any debt with or without security;
- f) subject to such consent as may be necessary demise or let out, sub-let or under let the Secured Assets or any part or parts thereof for such terms at such rents and generally in such manner and upon such conditions and stipulations as the Trustee or the Receiver shall think fit;
- g) exchange any part or parts of the Secured Assets for any other security or property suitable for the purposes of the Company whether forming part of the general assets or not and upon such terms as may seem expedient and either with or without payment or receipt of moneys for equality of exchange or otherwise;
- h) assent to the modification of any contracts or arrangements which may be subsisting in respect of any of the Secured Assets and, in particular the terms of any concession or licences for the time being held;
- i) execute and do all such acts, deeds and things as to the Trustee or the Receiver may appear necessary or proper for or in relation to any of the purposes aforesaid.

The Trustee or the Receiver so appointed may for any of the purposes aforesaid do or cause to be done all such acts and things in respect of the business and Secured Assets as the Trustee/Receiver could do or cause to be done if the Trustee/Receiver had the absolute possession of the Secured Assets and had carried on the said business for the benefit of the Trustee without being answerable for any loss or damage which may happen thereby.

3.5.3 Power of Trustee to borrow

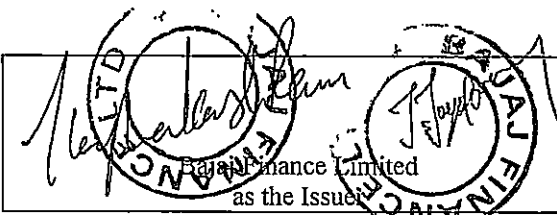
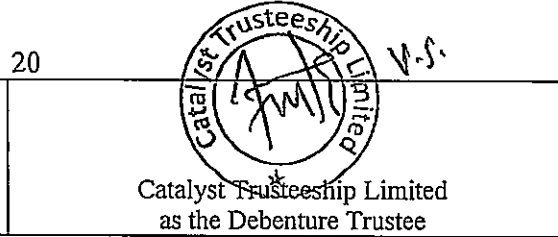
20	
 Catalyst Finance Limited as the Issuer	 Catalyst Trusteeship Limited as the Debenture Trustee

The Trustee may, upon the occurrence of an Event of Default, and the Security being enforceable, with the consent in writing of the Majority Debenture Holder(s) in a meeting convened in accordance with the provisions set out in the **Third Schedule** hereunder written, raise or borrow moneys on the security of the Secured Assets or any part thereof ranking *pari passu* with or subservient to these presents:

- (a) for the purpose of making any payment under or by virtue of these presents;
- (b) in relation to the exercise of any powers, duties or obligations of the Trustee or the Receiver;
- (c) otherwise in relation to the Secured Assets or these presents;
- (d) for the purpose of paying off or discharging charges for the time being on the Secured Assets or any part thereof; and / or
- (e) any costs, charges and expenses which shall be incurred by the Trustee under or by virtue of these presents.

The Trustee may raise and borrow such moneys as aforesaid at such rate or rates of interest and generally on such terms and conditions as the Trustee shall think fit.

3.6 Duties of Debenture Trustee

3.6.1 In performing its obligations in relation to the Debentures, the Debenture Trustee shall:

- (a) perform its duties and obligations, and exercise its rights and discretions, in keeping with the trust reposed in the Trustee by the Debenture Holder(s), and shall further conduct itself, and comply with the provisions of all Applicable Law, provided that, the provisions of Section 20 of the Indian Trusts Act, 1882, shall not be applicable to the Trustee;
- (b) carry out its duties and perform its functions as required to discharge its obligations under the terms of the Securities and Exchange Board of India (Issue and Listing of Non Convertible Securities) Regulations, 2021, SEBI (Debenture Trustees) Regulations, 1993, SEBI Defaults (Procedure) Circular, the SEBI Operational Circular for Debenture Trustees, the Debenture Trustee Agreement, Operational Guidelines Circular, the General Information Document, Shelf Disclosure Document / Disclosure Documents / Offer Letter / Prospectus and all other related Transaction Documents, with due care, diligence;
- (c) call for and obtain periodic status/ performance reports / valuation reports / utilization reports or any other documents from the Company, as may be required by the Debenture Trustee to comply with its obligations under the Applicable Laws including for monitoring of the Security Coverage Ratio and the creation and maintenance of Security, Recovery Expense Fund in relation to the Debentures;
- (d) issue letters / confirmations / no objection certificate, or any other communication as requested by the Company in accordance with the Transaction Documents;
- (e) ascertain and:

21

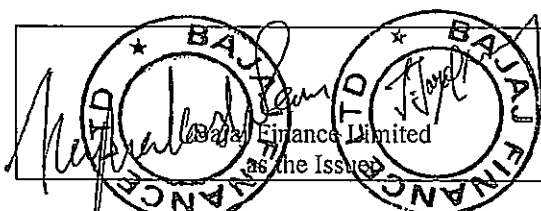
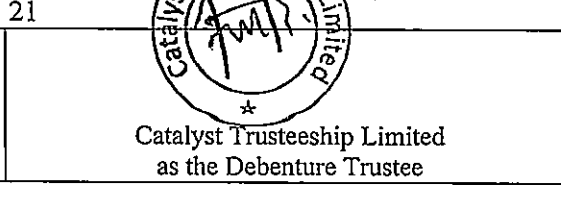
 <p>Baalaj Finance Limited as the Issuer</p>	 <p>Catalyst Trusteeship Limited as the Debenture Trustee</p>
---	---

- i. exercise due diligence to the extent required under Applicable Law, to ensure compliance by the Company, with the provisions of the Act, SEBI (Listing Obligations and Disclosure Requirement), Regulations, 2015, SEBI (Debenture Trustees) Regulations, 1993 this Deed or any other regulations issued by SEBI in the issue and allotment of the Debentures and credit of the Debentures in the demat accounts of the Debenture Holder(s);
 - ii. satisfy itself that interest due on the Debentures have been paid to the Debenture Holder(s) on or before the due dates;
 - iii. satisfy itself that Debenture Holder(s) have been paid the monies due to them on the date of Redemption of the Debentures.
- (f) exercise independent due diligence as required under Applicable Law, to ensure that Security to be created is free from any encumbrance or that Company has obtained the necessary consent from other charge-holders if the Security has an existing charge, prior to creation of the Security pursuant to this Deed;
 - (g) communicate promptly to the Debenture Holder(s) defaults, if any, with regard to payment of interest or Redemption of Debentures or occurrence of any other Event of Default which is known to the Trustee alongwith all information relating to cure periods (if any) and action taken or proposed to be taken by the Trustee therefor;
 - (h) carry out all its obligations, duties and functions as the Debenture Trustee in accordance with the terms set out in the Transaction Documents and where the same is silent or contrary to any other provision of the Transaction Documents, on the instructions of the Majority Debenture Holder(s);
 - (i) not do any act, deed or thing which is prejudicial or detrimental to the interest of the Debenture Holders and at all times act in the best interest of the Debenture Holder(s);
 - (j) shall not relinquish its assignment unless and until another debenture trustee has been appointed in its place;
 - (k) take possession of Secured Assets in accordance with the provisions of this Deed, the Transaction Documents and Applicable Law;
 - (l) inform SEBI immediately of any breach of this Deed or provision of any Applicable Law, which comes to its knowledge, if required under Applicable Laws;
 - (m) keep all customary books and records relating to the receipt and distribution of all moneys which it may receive or be entitled to hereunder or under any Transaction Documents;
 - (n) convene a meeting of the Debenture Holder(s) in accordance with Applicable Laws;

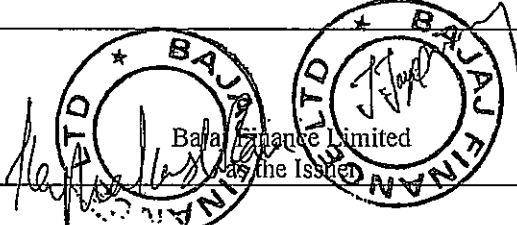
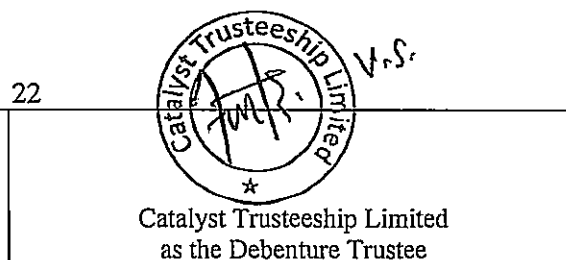
 <p>BAJAJ FINANCE LIMITED as the Issuer</p>	22	 <p>Catalyst Trusteeship Limited as the Debenture Trustee</p>
--	----	---

- (o) seek the status of payment from the Company and/or conduct independent assessment (viz., from the Account Bank, Debenture Holders, rating agencies etc.) to determine if the Company fails to intimate the status of payment of the Debentures within 1(one) working day of the Redemption Date. Based on such assessment, the Debenture Trustee shall intimate stock exchange(s) and Depository the status of payment within 9 (nine) working days of the Redemption Date or within such other revised timelines as may be prescribed under Applicable Law. Further, for continuous assessment of default status, the Debenture Trustee shall conduct independent assessment as given above and intimate the status of payment to the stock exchange(s) and Depository within 7th working day of April of each financial year, if the Company fails to provide the updated status of the payment of the Debentures within the 2nd working day of April of the relevant financial year;
- (p) subject to the approval of the Debenture Holder(s) and the conditions as may be specified by SEBI from time to time, enter into inter-creditor agreements provided under the framework specified by the RBI on behalf of the Debenture Holders;
- (q) issue a "No Objection Certificate" ("NOC") to the designated stock exchange for refund of balance in the Recovery Expense Fund to the Company on repayment of Secured Obligations in full to the satisfaction of the Debenture Holders. The Debenture Trustee shall satisfy that there is no 'default' on any other listed debt securities of the Company before issuing such NOC;
- (r) keep the information (pertaining to the details of bank account(s)) provided to it pursuant to the Chapter XI of Operational Guidelines Circular as confidential and shall use the same only to the extent as required under the Chapter XI of Operational Guidelines Circular; and
- (s) perform such acts as may be necessary for the protection of the interest of the Debenture Holder(s) and do all other acts as may be necessary in order to resolve the grievances of the Debenture Holder(s).
- (t) in case the Issuer fails to intimate the status of payment of the Debentures within stipulated timelines, then Debenture Trustee(s) shall seek status of payment from Issuer and/ or conduct independent assessment (from banks, investors, rating agencies, etc.) to determine the same. Based on such assessment, Debenture Trustee(s) shall intimate stock exchange and depositories the status of payment of Debentures within 9 (nine) working days of the maturity/ redemption date.
- (u) in case intimation of the status of payment of debt securities is not received by stock exchanges and depositories within stipulated timeline, transactions in such debt securities shall continue to be restricted and such restrictions shall continue until any further intimation is received from issuer/ debenture trustee(s) regarding the status of payment of such debt securities.
- (v) the Debenture Trustee shall access the database to verify the information regarding default history and other relevant information. In case of any discrepancy, Debenture Trustee shall notify the same to stock exchanges and

23

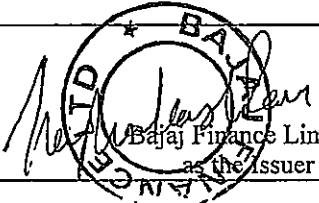
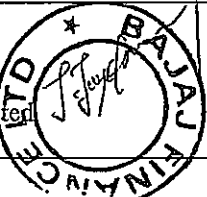
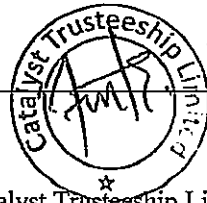
 Bajaj Finance Limited as the Issuer	 Catalyst Trusteeship Limited as the Debenture Trustee	 Catalyst Trusteeship Limited as the Debenture Trustee
---	---	--

update the correct information in the database, within the time stipulated in **Chapter XII** of the SEBI Operational Circular for Debenture Trustees.

- (w) the Debenture Trustee shall be vested with the requisite powers for protecting the interest of Debenture Holders of Debentures including a right to appoint a nominee director on the Board of the Issuer in consultation with Debenture Holders of such Debentures and in accordance with Applicable Law in the event of:
 - (i) two consecutive defaults in payment of interest to the debenture holders; or
 - (ii) default in creation of security for debentures; or
 - (iii) default in redemption of debentures.
- (x) the Debenture Trustee shall supervise the implementation of the conditions, creation of Recovery Expense Fund and Debenture Redemption Reserve, as applicable.
- (y) the Debenture Trustee shall monitor the Security Cover in relation to secured Debentures in the manner as specified by the Board.

4. EVENTS OF DEFAULT

4.1. The occurrence of any one of the following events shall constitute an “**Event of Default**” by the Company:

4.1.1 Default in redemption of debentures

Default shall have occurred in the Redemption of the Debentures together with redemption premium, if any, as and when the same shall have become due and payable.

4.1.2 Default in payment of interest

Any default by the Company in the payment of any installment of interest of the Debentures, as and when the same shall have become due and payable.

4.1.3 Default in performance of covenants and conditions

If the Company commits a breach of any of the covenants, conditions or provisions contained in the Transaction Documents which breach is incapable of remedy or, if in the opinion of the Trustee, capable of remedy, is not remedied within 90 (ninety) Business Days after written notice of such breach has been given to the Company by the Trustee.

4.1.4 Company ceases to carry on business

If the Company ceases with/without the consent of the Debenture Holder(s) or threatens to cease to carry on its business or gives notice of its intention to do so or of if it appears to the Trustee that the Company is carrying on business at such a loss, that the further continuation by the Company of its business will endanger the Security.

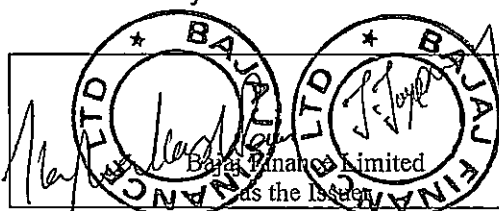
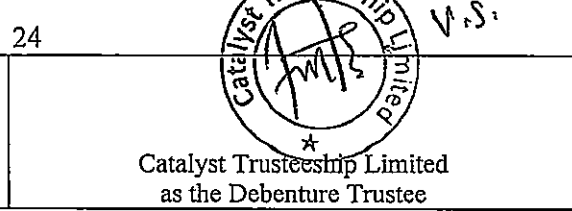
24	V.S.
 Baha Finance Limited as the Issuer	 Catalyst Trusteeship Limited as the Debenture Trustee

4.1.5 Inability to pay debts

If the Company is unable to or admits in writing its inability to pay its debts as they mature or proceedings for taking it into insolvency or liquidation have been admitted by any competent court or a special resolution has been passed by the shareholders for winding up of the Company or for filing an application and admission thereof to initiate insolvency resolution process of the Company or it is certified by the statutory auditors that the liabilities of the Company exceed its assets indicating the inability of the Company to discharge its obligations under this Deed.

4.1.6 Proceedings against Company

The Company shall have voluntarily become the subject of or involuntarily admitted to the proceedings under bankruptcy or insolvency law, or has suffered any action taken for its reorganization, insolvency, liquidation or dissolution; or

A receiver or resolution professional or liquidator is appointed or allowed to be appointed in respect of all or any part of the undertaking of the Company.

4.1.7 Security is in jeopardy

- (a) When the Company creates or attempts to create any charge on the Secured Assets or any part thereof, other than the Permitted Security Interest, without the prior approval of the Trustees/Debenture Holder(s) or if, in the reasonable opinion of the Debenture Trustee, the Security is in jeopardy or the Security Coverage Ratio is not maintained by the Company; and
- (b) If any Security Document once executed and delivered, ceases to be in full force and effect or fails to provide the Debenture Trustee and the Debenture Holder(s)/Beneficial Owner(s) with the Security Interest intended to be created thereby.

4.1.8 Misleading Information



Any information given by the Company in the General Information Document / Key Information Document / Disclosure Documents/Prospectus / Offer Letter, the Transaction Documents and/or other information furnished and/or the representations and warranties given/deemed to have been given by the Company to the Debenture Holder(s)/Beneficial Owner(s) for availing financial assistance by way of subscription to the Debentures is or proves to be misleading or incorrect in any material respect or is found to be incorrect.

4.1.9 Attachment or Distraint

If an attachment or distraint is levied on the Secured Assets or any part thereof and / or certificate proceedings are taken or commenced for recovery of any dues from the Company.

- 4.1.10 If extraordinary circumstances have occurred which make it improbable for the Company to fulfill its obligations under this Deed and/or the Debentures in the opinion of the Debenture Trustee.

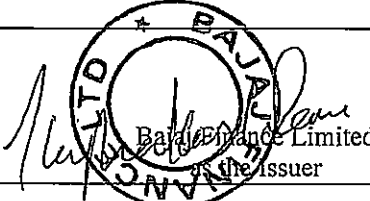
25

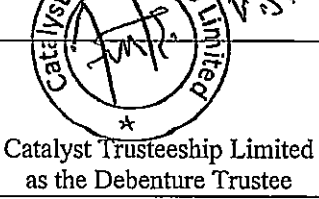
 <p>Baid Finance Limited as the Issuer</p>	 <p>Baid Finance Limited as the Issuer</p>	 <p>Catalyst Trusteeship Limited as the Debenture Trustee</p>
---	---	---

4.1.11 If it is certified by the Statutory Auditors that the liabilities of the Company exceed its assets indicating the inability of the Company to discharge its obligations under this Deed.

4.1.12 Expropriation / Nationalisation

If any Governmental Authority shall have condemned, nationalized, seized, or otherwise expropriated all or any substantial part of the assets of the Company or of the shares of the Company held by any director or the promoters, or shall have assumed custody or control of such shares or the business or operations of the Company or shall have taken any action for the dissolution of the Company or any action that would prevent the Company or its officers from carrying on its business or operations or a substantial part thereof.

4.1.13 Clearances

Any of the necessary clearances required or desirable in relation to the Debentures in accordance with any of the Transaction Documents is not received or is revoked or terminated, withdrawn, suspended, modified or withheld or shall cease to be in full force and effect which shall, in the reasonable opinion of Debenture Holder(s)/Beneficial Owners(s), have Material Adverse Effect on the Company or the Debentures.

4.1.14 Unlawfulness

It is or becomes unlawful for the Company to perform any of its material obligations under any Transaction Document in the opinion of the Debenture Holder/Beneficial Owner(s), of which such opinion shall not be arbitrary and substantiated and that the Company fails to make the payment.

4.1.15 Material Adverse Effect

The occurrence of any event or condition which, in the reasonable opinion of the Trustee or the Debenture Holder(s)/ Beneficial Owners(s), constitutes a Material Adverse Effect.

Any other event described as an Event of Default in the General Information Document / Prospectus / Offer Letter / Key Information Document and the Transaction Documents.

4.2. Consequences of Events of Default

4.2.1 After the occurrence of an Event of Default under Clause 4.1 above, and the expiry of cure periods (if any) the Debenture Trustee shall send a notice to the Debenture Holder(s) (along with a copy to the Company) within 3 (three) days of the Event of Default by registered post/acknowledgement due or speed post/acknowledgement due or courier or hand delivery with proof of delivery or through email as a text or as an attachment to email with a notification including a read receipt, and proof of dispatch of such notice or email, shall be maintained.

26

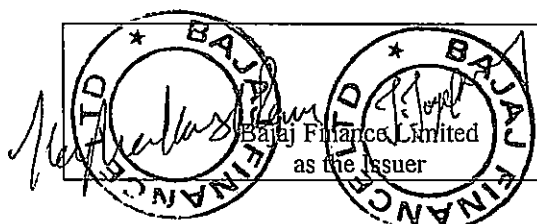
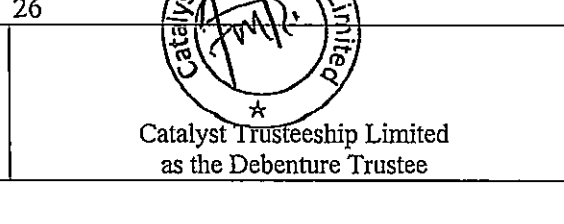
 <p>Bajaj Finance Limited as the Issuer</p>	 <p>Catalyst Trusteeship Limited as the Debenture Trustee</p>
--	---

4.2.2 The notice shall contain the following:

- (a) request for negative consent for proceeding with the enforcement of security;
- (b) request for positive consent for signing of the ICA;
- (c) the time period within which the consent needs to be provided by the Debenture Holder(s), viz. consent to be given within 15 (fifteen) days from the date of notice or such revised timelines as prescribed under Applicable Law; and
- (d) the date of meeting to be convened (which shall be within 30 (thirty) days of the occurrence of Event of Default).

Provided that in case the Event of Default is cured between the date of notice and the date of meeting, then the convening of such a meeting may be dispensed with.

4.2.3 The Debenture Trustee shall take necessary action of either enforcing the Security or entering into the ICA or take any other action as decided in the meeting of Debenture Holder(s) based on the decision of the Debenture Holder(s) with Special Majority, including the decision of formation of a representative committee of the Debenture Holder(s) to participate in the ICA or to enforce the Security or as may be decided in the meeting of Debenture Holder(s). Such a committee, if decided to be formed, may comprise of the designated members representing the interest of the ISIN level Debenture Holder(s) under the Debentures and be responsible to take decisions which shall be binding on the specific ISIN level Debenture Holder(s) relating to ICA matters, or in relation to enforcement of the Security, or take any other action as may be decided by the Debenture Holder(s), from time to time.



The Debenture Trustee(s) may in accordance with the decision of the Debenture Holder(s), sign the ICA and consider the resolution plan, if any, on behalf of the Debenture Holder(s)/ Beneficial Owners in accordance with the requirements under the extant RBI guidelines, SEBI circulars, guidelines and other Applicable Laws. The manner of voting for joining the Inter Creditor Agreement shall be as per the extant guidelines and circular notified by SEBI from time to time.

4.2.4 The Trustee shall also have the following rights (notwithstanding anything in these presents to the contrary):

- (a) to enforce any Security created pursuant to the Security Documents in accordance with the terms thereof, as may be set out therein, towards Repayment of the Secured Obligations;
- (b) to appoint a nominee director as per the SEBI (Debenture Trustee) Regulations, 1993 on the board of directors of the Company or to appoint an observer to all meetings of the board of directors of the Company, in the manner more particularly set out in Clause 10.20 of this Deed;
- (c) to initiate any enforcement action including without limitation under SARFAESI Act, 2002, Insolvency and Bankruptcy Code, 2016 (wherever applicable), or any other Applicable Law;
- (d) to levy default interest on overdue amounts as per the terms of issue; and
- (e) to exercise such other rights as the Debenture Holder(s) may deem fit under Applicable Law.

4.2.5 The Debenture Trustee after obtaining consent of Debenture Holder(s) for enforcement shall inform the designated stock exchange seeking release of the

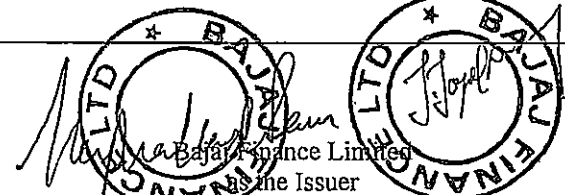
27

 <p>Bajaj Finance Limited as the Issuer</p>	 <p>Catalyst Trusteeship Limited as the Debenture Trustee</p>
--	---

Recovery Expense Fund. The Debenture Trustee shall follow the procedure set out in the SEBI Master Circular for Debenture Trustees for utilisation of the Recovery Expense Fund and be obligated to keep proper account of all expenses, costs including but not limited to legal expenses, hosting of meetings etc., incurred out of the Recovery Expense Fund towards enforcement of Security.

4.2.6 All expenses over and above those met from the Recovery Expense Fund incurred by the Beneficial Owner(s)/Trustee after an Event of Default has occurred in connection with:

- (a) preservation of the Secured Assets (whether then or thereafter existing); and
- (b) collection of amounts due under this Deed,

shall be payable by the Company.

4.2.7 Without prejudice to the obligation of the Trustee to monitor the Security Coverage Ratio and the Security in respect of the Debentures and to take necessary enforcement actions in accordance with the Transaction Documents, it is hereby clarified that the Trustee shall not be liable in any manner to guarantee the recovery of the entire outstanding amounts in relation to the Debentures.

5. COVENANTS

5.1. General Undertakings/ Obligations

5.1.1. The Company shall as required by Section 88 of the Act, keep at its registered office/ corporate office a Register of the Debenture Holder(s) holding Debentures, in physical form showing (a) the name and address and the occupation, if any, of each holder, (b) the amount of the Debentures held by each holder distinguishing each Debenture by its number and the amount paid or agreed to be considered as paid on those Debentures, (c) the date on which each person was entered in the Register as a Debenture Holder, (d) the date on which any person ceased to be a Debenture Holder, and (e) the subsequent transfers and changes of ownership thereof.

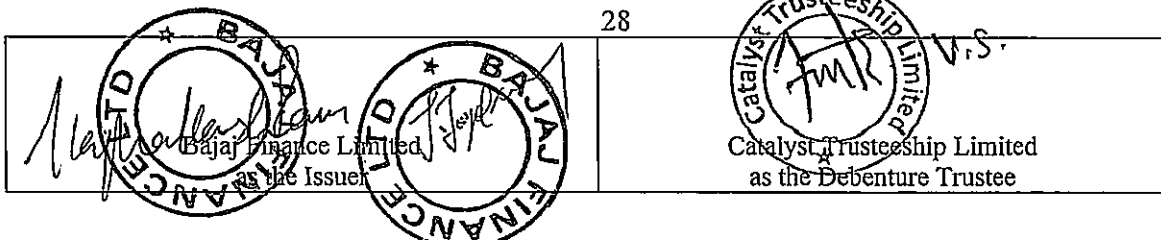

The Debenture Trustee and/or the Debenture Holder(s) or any of them or any other person shall, as provided in Section 94 of the Act, be entitled to inspect the said Register and to take copies of or extracts from the same or any part thereof during usual business hours. The Register may be closed by the Company at such time and for such periods as it may think fit in accordance with the provisions of the Act after giving not less than 7 (seven) days' previous notice or such notice as prescribed under Applicable Law by advertisement in some newspaper circulating in the district in which the Company's registered office is situate. No transfer will be registered during such period when the register of Debenture Holder(s) remains closed.

5.1.2. The Company shall request the Depository to provide a list of Beneficial Owner(s) showing (a) the name, address and the occupation, if any, of each Debenture Holder, (b) the amount of the Debentures held by each Debenture Holder distinguishing each Debenture by its number and the amount paid or agreed to be considered as paid on those Debentures, (c) the date on which each person was entered in the list as a Debenture Holder, (d) the date on which any person ceased to be a Debenture Holder, and (e) the subsequent transfers and changes of ownership thereof, as at the end of day 1 (one) day prior to the start of the book closure period or at the Record

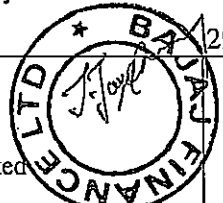

Date, as the case may be. This shall be the list which shall be considered for payment of interest and Redemption of Debentures.

- 5.1.3. The Company shall keep proper books of account as required by the Act and make true and proper entries therein of all dealings and transactions of and in relation to the Secured Assets and the business of the Company and keep the said books of account and all other books, registers and other documents relating to the affairs of the Company at its registered office or, where permitted by law, at other place or places where the books of account and documents of a similar nature may be kept and the Company will ensure that all entries in the same relating to the Secured Assets and the business of the Company shall at reasonable times be open for inspection of the Trustee and such person or persons, as the Trustee shall, from time to time, in writing for that purpose appoint.
- 5.1.4. The Company shall comply with all applicable directions, regulations and guidelines issued by any Governmental Authority including but not limited to the issue of Debentures.
- 5.1.5. So long as the Debenture Holder(s) continue to hold the Debentures, the Company agrees and undertakes to comply with all Applicable Laws including the Companies Act, 2013, all provisions of applicable SEBI regulations including SEBI (Debenture Trustee) Regulations, 1993 (as amended from time to time), SEBI (Issue and Listing of Non Convertible Securities) Regulations, 2021 (as amended from time to time), SEBI (Listing Obligations and Disclosure Requirements) Regulations, 2015 (as amended from time to time), the debt listing agreement entered into with the stock exchanges (where the Debentures are listed/ proposed to be listed). This Deed is also subject to such guidelines as may be issued by SEBI, Government of India, such other statutory or regulatory authorities from time to time.
- 5.1.6. The Company shall ensure that the Required Security Cover which is in accordance with the applicable regulations and circulars of the SEBI as amended from time to time, including the SEBI circular dated 19 May 2022, on 'Revised format of security cover certificate, monitoring and revisions in timelines' is also maintained.
- 5.1.7. The Company shall pay and discharge all Taxes, rates, rents and governmental charges upon the Company or its assets under Applicable Laws.
- 5.1.8. The Company shall transfer unclaimed/unpaid interest on debentures and redemption of debentures to "Investor Education and Protection Fund" as per Section 125 of the Companies Act 2013 and shall not forfeit unclaimed interest.
- 5.1.9. The Company shall create and maintain a reserve to be called the "**Recovery Expense Fund**" as per the provisions of and in the manner provided in the SEBI (Debenture Trustee) Amendment Regulations, 2020, the SEBI Master Circular for Debenture Trustees and any guidelines and regulations issued by SEBI, as applicable. The Recovery Expense Fund shall be created to enable the Debenture Trustee to take prompt action in relation to the enforcement of the Security in accordance with the Transaction Documents. The Company shall submit to the Trustee certificate duly certified by an authorised signatory of the company certifying creation and the form of such Recovery Expense Fund by the Company prior to the opening of the issue. The balance in the Recovery Expense Fund shall be refunded to the company on repayment of Secured Obligations to the Debenture Holders for

 Manoj Kumar Bajaj Finance Limited as the Issuer	 Anil Catalyst Trusteeship Limited as the Debenture Trustee	 Anil Catalyst Trusteeship Limited as the Debenture Trustee
--	---	--

which a 'No Objection Certificate (NOC)' shall be issued by the Debenture Trustee(s) to the designated stock exchange. The Debenture Trustee(s) shall satisfy that there is no 'default' on any other listed debt securities of the Company before issuing the said NOC.

- 5.1.10.** The Company hereby agrees that, if applicable, it would create a debenture redemption reserve in accordance with provisions of the Companies Act, 2013 ("Debenture Redemption Reserve") and/or any guidelines issued by SEBI / RBI as made applicable to it and if during the currency of these presents, any guidelines are formulated (or modified or revised) by the Government Authority having authority under the law in respect of creation of Debenture Redemption Reserve, the Company shall abide by such guidelines and execute all such supplemental letters, agreements and deeds of modification as may be required by the Debenture Holder(s) or the Trustee. The Company shall submit to the Trustee a certificate duly certified by the Auditors (if required by regulations) certifying that the Company has transferred suitable sum to the Debenture Redemption Reserve in accordance with the Applicable Laws.
- 5.1.11.** The Company hereby agrees and undertakes that, if during the currency of these presents, any further guidelines are formulated (or modified or revised) by any Governmental Authority in respect of investment of the monies lying therein and/or Recovery Expense Fund, the Company shall duly abide by such guidelines and execute all such supplemental letters, agreements and deeds of modifications as may be required by the Debenture Holder(s)/ Beneficial Owner(s) or the Trustee.
- 5.1.12.** The Company shall take all steps for completion of the formalities for listing and commencement of trading at all the concerned stock exchange(s) in respect of the Debentures.
- 5.1.13.** The Company shall ensure, and/or cause the Registrars to an issue and Share Transfer Agent to forward the details of Debenture Holder(s) to the Debenture Trustee at the time of allotment and thereafter by the seventh working day of every next month in order to enable Debenture Trustee to keep its records updated and to communicate effectively with the Debenture Holders, especially in situations where Events of Default have occurred.
- 5.1.14.** The Company agrees and undertakes to constitute a stakeholders' relationship committee, in terms of the SEBI (Listing Obligations and Disclosure Requirements) Regulations, 2015) and Companies Act, 2013 to look into the mechanism of redressal of grievances of the Debenture Holders.
- 5.1.15.** The Company hereby agrees, confirms and undertakes that in the event the Company has failed to make a timely Repayment of the Secured Obligations or to create a charge on the Secured Assets or there is a revision of rating assigned to the Debentures, the Trustee shall, be entitled to disclose the information to the Debenture Holder(s) and the general public by issuing a press release, placing the same on their websites and with the credit rating agencies.
- 5.1.16.** The Company shall maintain a functional website containing correct and updated information as required by SEBI (Listing Obligation and Disclosure Requirements) Regulations, 2015 as amended from time to time and other Applicable Laws.

30

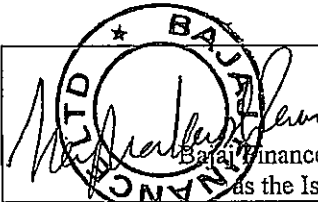
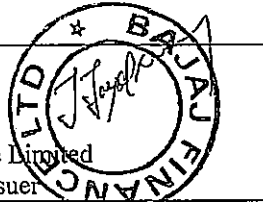
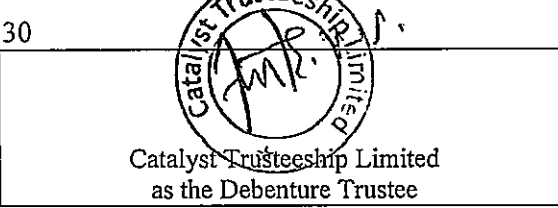
 Bajaj Finance Limited as the Issuer		 Catalyst Trusteeship Limited as the Debenture Trustee
---	---	--

5.1.17. The Company hereby irrevocably and unconditionally appoints the Trustee to be the lawful attorney of the Company in the name and on behalf of the Company to execute, sign and do any deeds, documents, assurances, acts and things which shall in the opinion of the Trustee be necessary or expedient that the Company should execute, sign and do for the purpose of carrying out any of the trusts of obligations declared or imposed upon the Company by these presents or of giving to the Debenture Holder(s)/ Beneficial Owner(s) or to the Trustee on their behalf the full benefit of any of the provisions of these presents and generally to use the name of the Company in the exercise of all or any of the powers hereby conferred upon the Trustee or any Receiver appointed by them.



5.1.18. Subject to the Applicable Law, the Company may at its discretion by giving 15 (fifteen) days' notice or such notice as prescribed under Applicable Law, seek the roll-over of any or all the Debenture. If the proposed roll over of the Debentures is approved by the Debenture Holder(s) by passing of a Special Resolution by them, the Company shall roll over the debentures in accordance with the approval of the Debenture Holders. Provided however that Company shall redeem the Debenture(s) of all the Debenture Holder(s), who have not given their positive consent to such roll-over.

5.1.19. The Company shall pay all such stamp duty as applicable on the Debentures and execution of this Deed and shall pay all such stamp duty (including any additional stamp duty, if any), other duties, Taxes, charges and penalties, if and when the Company may be required to pay according to the laws for the time being in force in the State in which its properties are situated or otherwise, and in the event of the Company failing to pay such stamp duty, other duties, Taxes and penalties as aforesaid, the Trustee will be at liberty (but shall not be bound) to pay the same and the Company shall reimburse the same to the Trustee on demand.

5.1.20. The Company undertakes that it shall:

- a) at all times, obtain and maintain, or cause to be obtained and maintained, in full force and effect (or where appropriate, renew) all clearances/ authorizations required for the purposes of the business and all transactions as contemplated by the Transaction Documents, non-procuring or non-renewal whereof shall have a Material Adverse Effect.
- b) create all Security and execute all the Security Documents as may be required by the Trustee as per the terms hereof and shall ensure that all Transaction Documents, when executed, shall constitute its legal, valid and binding obligations under Applicable Law.
- c) attend to the complaints received in respect of the Debentures expeditiously and satisfactorily.
- d) if any of the Directors of the Company are added to any defaulter's list by any Governmental Authority, take immediate steps forthwith to remove such person from its Board.
- e) duly cause these presents to be registered in all respects so as to comply with the provisions of the Act and also cause these presents to be registered in conformity with the provisions of the Indian Registration Act, 1908 or any act, ordinance or regulation applicable in any part of India, within which any

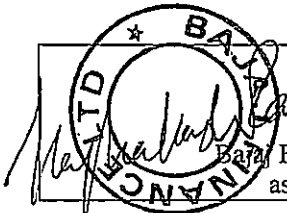
31

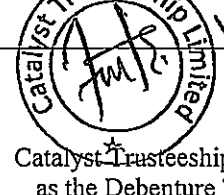
 BNP Finance Limited as the Issuer	 Catalyst Trusteeship Limited as the Debenture Trustee	 Catalyst Trusteeship Limited as the Debenture Trustee
---	---	--

portion of the Secured Assets are or may be situated, by which the registration of deeds is required and generally do all other acts (if any) necessary for the purpose of assuring the legal validity of these presents.

f) have no objection and hereby agrees, confirms and undertakes that in the event the Company has failed to make a timely Repayment of the Secured Obligations:

- (i) the Trustee shall, as the Trustee may deem appropriate and necessary, be entitled to disclose all or any:
 - (1) information and data relating to the Company,
 - (2) information or data relating to this Deed;
 - (3) default committed by the Company in discharge of the obligations under the Transaction Documents, to TransUnion CIBIL Limited ("TransUnion CIBIL") and any other agency authorised in this behalf by RBI;
- (ii) TransUnion CIBIL and / or any other agency so authorised may use, process the aforesaid information and data disclosed by the Trustee in the manner as deemed fit by them;
- (iii) TransUnion CIBIL and / or any other agency so authorised may furnish for consideration, the processed information and data or products thereof prepared by them, to the Trustee, and other credit grantors or registered users, as may be specified by RBI in this behalf;

5.1.21. The Company agrees that no immunity (if acquired) shall be claimed by it or on its behalf with respect to its assets in any proceedings in relation to its obligations under the Transaction Documents and shall waive any such right of immunity which it or its assets has or may acquire. The execution of this Deed constitutes, and the exercise of its rights and performance of and compliance with its obligations under this Deed will constitute, private and commercial acts done and performed for private and commercial purposes.



5.1.22. The Company declares and undertakes that it has obtained the necessary permissions as may be required, for entering into the Transaction Documents, and shall execute the same within the time frame prescribed under the relevant SEBI regulations and circulars and furthermore, shall submit such Transaction Documents to the stock exchange for uploading on its website.

5.1.23. The Company undertakes that the permission/consent from the existing charge holders / creditors (represented by their trustees) for a first *pari passu* charge being created under this Deed, where applicable, in favour of the trustees to the proposed issue has been obtained.

5.1.24. The Company shall ensure that the audited financial statements disclosed in the Information Memorandum, as the case may be, should not be more than 6 (six) months old from the date of filing Information Memorandum or the Issue Opening Date.

5.1.25. The Company shall treat all applicants to an issue of Debentures in a fair and equitable manner as per the procedures as may be specified by the Board.

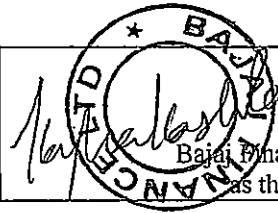
32

 Bajaj Finance Limited as the Issuer	 Catalyst Trusteeship Limited as the Debenture Trustee
---	---

5.1.26. The Company shall continue with the Securities and Exchange Board of India Complaints Redress System (SCORES) authentication in the format specified by the Board and shall use the same for all issuance of Debentures.

5.1.27. The Company shall disclose details of all default/s and/or delay in payments of interest and principal of any kind of term loans, debt securities and other financial indebtedness including corporate guarantee issued by the Company, in the past 3 (three) years including the current financial year.

5.1.28. The company shall appoint the person nominated by the debenture trustee(s) in terms of clause (e) of sub-regulation (1) of regulation 15 of the Securities and Exchange Board of India (Debenture Trustees) Regulations, 1993, as a director on its Board of Directors at the earliest and not later than one month from the date of receipt of nomination from the debenture trustee(s) as to appointment of Nominee Director.

5.2. Information Covenants

The Company shall provide the relevant information set out in the Fourth Schedule hereto, in the manner and within the time period stipulated therein.

5.3. Negative Covenants

5.3.1. The Company shall not, without prior intimation to the Debenture Trustee, make any change in the nature and conduct of its business which is likely detrimental or affect the interest of the debenture holder (from what is being carried out as on the date hereof), other than the objects as set out in its Memorandum of Association.

5.3.2. The Company shall not make any material modification to the structure of the Debentures in terms of coupon, conversion, Redemption, or otherwise without the prior approval of the stock exchange and such prior approval of the stock exchange would be obtained only after: (a) approval of the Board and the Debenture Trustee; and (b) complying with the provisions of Companies Act, 2013 and SEBI (Listing Obligation and Disclosure Requirements) Regulation, 2015 as amended from time to time including approval of the requisite majority of Debenture Holder(s). Further, any proposal of restructuring received by Debenture Trustee shall be communicated to Debenture Holder(s) immediately.

5.3.3. The Company shall not, without the prior consent of the Debenture Trustee, make any investment by way of deposits, loans, bonds, share capital, or in any other form upon the occurrence of default in payment of interest or/and principal on the Debentures.

5.3.4. The Company shall not, upon the occurrence of default in payment of interest or/and principal on the Debentures, without the prior consent of the Debenture Trustee, directly or indirectly contract, create, incur, assume or suffer to exist any indebtedness or borrowing arrangement, either secured or unsecured, with any other bank, financial institution, company or otherwise or accept deposits, except as otherwise permitted herein.

5.3.5. In an event of not meeting Security Coverage Ratio, the Company shall not create further charge or encumbrance of the Secured Assets other than the Permitted

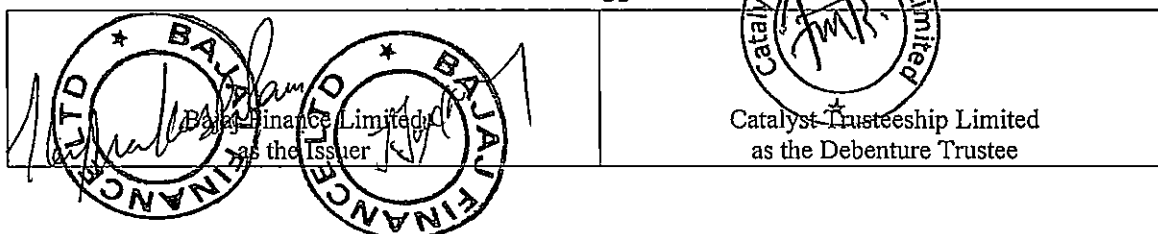

Security Interest, without prior approval of the Trustee and the Debenture Holder(s) /Beneficial Owners subject to clause 7.6 hereunder.

- 5.3.6. The Company shall not, without the prior consent of the Debenture Trustee, abandon or agree to abandon its business if it adversely impacts the Security Coverage Ratio
- 5.3.7. The Company shall so long as the Debentures are outstanding, not declare any dividend to the shareholders in any year until the Company has paid or made satisfactory provision for the payment of the instalments of principal and interest due on the Debentures.
- 5.3.8. The Company shall not, without the prior consent of the Debenture Trustee, carry out any amendments or alterations to the memorandum of association and articles of association, which would prohibit the consummation of the transactions contemplated under the Transaction Documents or otherwise prejudice to the rights/interest of the Debenture Holders.
- 5.3.9. The Company shall not, without the prior consent of the Debenture Trustee, voluntarily wind up or liquidate or dissolve its affairs or make any filing for initiation of corporate insolvency resolution process or liquidation under the Insolvency and Bankruptcy Code, 2016 or under any other Applicable Laws.
- 5.3.10. The Company shall not employ any device, scheme, or artifice to defraud in connection with issue or subscription or distribution of Debentures which are listed or proposed to be listed on the recognized stock exchange(s).
- 5.3.11. Disposal of Assets: In case of breach in maintaining Security Coverage Ratio, the Company shall not sell, transfer, or otherwise dispose of in any manner whatsoever any material Assets of the Company, sell any business/division that has the effect of exiting the business or re-structuring of the existing business, without the prior consent of the Debenture Trustee, other than any securitization/portfolio sale of assets undertaken by the Company in its ordinary course of business. In case of breach in maintaining Security Coverage Ratio, the Issuer shall not undertake any new major new business outside financial services or any diversification of its business outside financial services, without approval of the Debenture Trustee.
- 5.3.12. The Company shall not voluntarily suffer any act, which has a Material Adverse Effect on its business profits or sales without intimation to the Debenture Trustee.

6. COMPANY'S REPRESENTATIONS AND WARRANTIES



6.1. Representations

On the date hereof and on every Redemption Date and date for payment of coupon, the Company makes the representations and warranties to the Trustee as set out hereto:

a. Status

The Company is a company, duly incorporated and validly existing under the law of its jurisdiction of incorporation and has the right to own its assets and

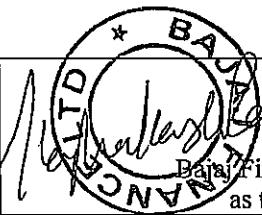
34

 BAJAJ FINANCE LIMITED as the Issuer	 Catalyst Trusteeship Limited as the Debenture Trustee
---	--

carry on its business as it is being conducted, under the law of its jurisdiction of incorporation.

b. Binding obligations

The obligations expressed to be assumed by the Company under each of the Transaction Documents, to which it is a party, are legal, valid, binding and subject to any general principles of law limiting its obligations.

c. Non-conflict with other obligations

The entry into and performance by the Company of, and the transactions contemplated by, the Transaction Documents to which it is a party, do not and will not conflict with:

- (i) any Applicable Law or order, writ, injunction or decree of any court or Governmental Authority having jurisdiction over the Company;
- (ii) its constitutional documents; or
- (iii) any agreement or instrument binding upon it or any of its assets.

d. Validity and admissibility in evidence

All authorisations required or desirable to make the Transaction Documents to which the Company is a party, admissible in evidence in its jurisdiction of incorporation, have been obtained or effected and are in full force and effect.

e. Compliance with laws

The Company is in material compliance with Applicable Laws, with all Tax laws in all jurisdictions in which it is subject to Tax and is not subject to any present liability by reason of non-compliance with such Applicable Law as would materially affect the ability of the Company to conduct the business. The Company has paid all Taxes due and payable by it (save and except for the Tax claims which are being contested by the Company in good faith before appropriate forums and has been disclosed to the Debenture Trustee in writing) and no claims have been asserted or are being asserted against it in respect of Taxes as would affect the ability of the Company to conduct its business.

f. Eligible Issuer

The Company represents that the Company is an eligible issuer as per Regulation 5 of the SEBI (Issue and Listing of Non Convertible Securities) Regulations, 2021.

g. No Event of default

- (i) No Event of Default is continuing or might reasonably be expected to result from the entering into or performance by the Company of any of the Transaction Documents.
- (ii) No other event or circumstance is outstanding which constitutes (or would to the best of the knowledge of the Company do so with the expiry of the cure period/grace period, the giving of notice, the making of any

35

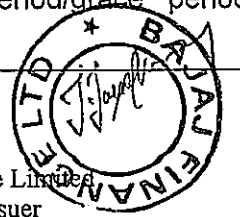
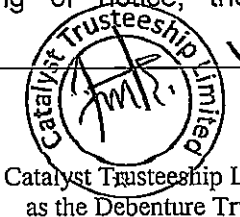
 Raj Finance Limited as the Issuer	 Catalyst Trusteeship Limited as the Debenture Trustee	 V.S. Catalyst Trusteeship Limited as the Debenture Trustee
---	---	--

determination, the satisfaction of any other condition or any combination of any of the foregoing) an Event of Default (howsoever described) under any other lending agreement or instrument which is binding on it or to which its assets are subject.

h. No misleading information

- (i) Any factual information provided by or on behalf of the Company in connection with the issue of the Debentures are true and accurate in all material respects as at the date it was provided or as at the date (if any) at which it is stated.
- (ii) Nothing has been omitted from any information provided to the Debenture Trustee and no information has been given or withheld that results in such information being untrue or misleading in any material respect

i. No proceedings pending or threatened

No litigation, arbitration, investigative or administrative proceedings of or before any court, arbitral body or agency which, if adversely determined, will have a Material Adverse Effect, have (to the best of its knowledge and belief after due and careful enquiry and except as already disclosed to the Trustee) been started against the Company.

j. Title

The Company has good and marketable title to all material assets necessary or desirable for it to carry on its business as it is being or is proposed to be conducted.

k. No immunity

The Company's assets are not entitled to immunity from suit, execution, attachment or other legal process India.

l. Solvency

- (i) The Company is able to, and has not admitted its inability to, pay its debts as they mature and has not suspended making payment on any of its debts.
- (ii) The Company, by reason of actual or anticipated financial difficulties, has not commenced, and does not intend to commence, negotiations with one or more of its creditors with a view to rescheduling any of its indebtedness.
- (iii) The value of the assets of the Company is more than its liabilities (taking into account contingent and prospective liabilities) and it has sufficient capital to carry on its business.
- (iv) No moratorium has been declared in respect of any indebtedness of the Company.

m. Approvals

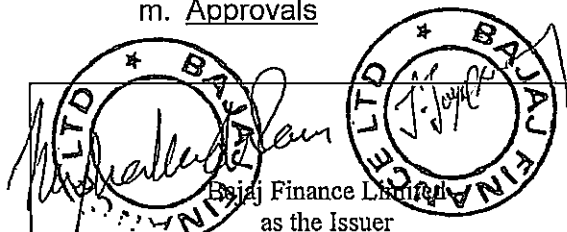
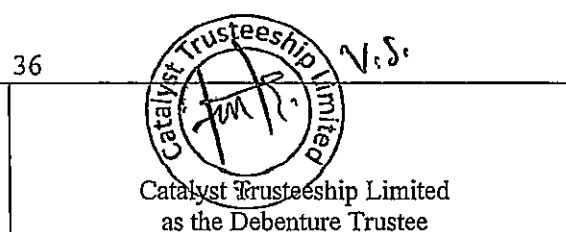
 <p>Bajaj Finance Limited as the Issuer</p>	<p>36</p>  <p>Catalyst Trusteeship Limited as the Debenture Trustee</p>
--	---

Except for any approvals as may be required in connection with the business subsequent to the date hereof, the Company hereby confirms that all approvals necessary under Applicable Law with respect to the business of the Company, have been taken by it and the same are valid and subsisting as at the date hereof.

n. Defaulter's List

The names of the Company and/ or its directors do not figure in any list of defaulters circulated by the RBI or any bank or financial institution nor do the names of its directors appear in caution list issued by RBI/ Export Credit Guarantee Corporation / Director General of Foreign Trade etc.

o. Remuneration/ expenses of Debenture Trustee

The remuneration/ fees/ expenses payable to the Debenture Trustee pursuant to the terms of the Transaction Documents arises on account of the provision of services by the Debenture Trustee and the obligations undertaken by the Debenture Trustee under the Transaction Documents are in the nature of service.

p. Payment of interest in case of failure to execute the Debenture Trust Deed

In case of failure to execute the Debenture Trust Deed within such timelines as may be specified by the SEBI, the Issuer shall pay interest of at least 2 % (two percent) per annum or such other rate, as specified by the SEBI, to the Debenture Holders, over and above the agreed coupon rate until the execution of the Debenture Trust Deed.

q. Intimation on status of payment

- (i) Issuer shall intimate to the stock exchanges, depositories and Debenture Trustee the status of payment of Debentures within 1 (one) working day of payment/ redemption date.
- (ii) While intimating the status of payment to Debenture trustee(s), Issuer shall also intimate to Debenture Trustee that they have informed the status of payment or otherwise to the stock exchanges and depositories.

r. Continuous assessment of default status

- (i) The issuer shall inform the stock exchange(s), depositories and Debenture Trustee latest by the second working day of April of each financial year on the updated status of payment of the Debentures.
- (ii) In case the issuer fails to intimate the updated status of payment of the concerned Debentures within the stipulated timelines, the Debenture Trustee shall carry independent assessment as given Clause 3.6.1 (o) above and intimate the status of payment of debt securities to the stock exchange and depositories within seventh working day of April of each financial year.

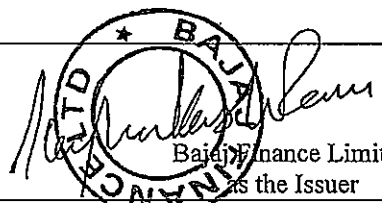
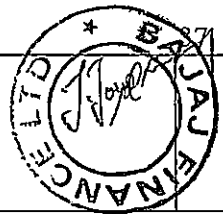
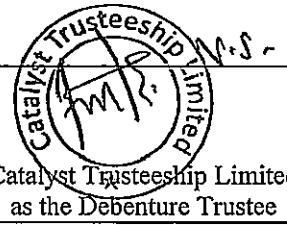
 Bajaj Finance Limited as the Issuer	 Catalyst Trusteeship Limited as the Debenture Trustee	 Catalyst Trusteeship Limited as the Debenture Trustee
---	---	--

(iii) In case issuer or Debenture Trustee does not intimate the status of payment of Debentures to stock exchanges and depositories within the stipulated timeline, transactions in such Debentures shall be restricted from eighth working day of April of that financial year, until any further intimation is received from Issuer or Debenture Trustee regarding the same.

(iv) In case of any developments that impact the status of default of the Debentures (including restructuring of Debentures, NCLT/ NCLAT proceedings relating to insolvency/ bankruptcy, repayment, etc.), the Issuer/ Debenture Trustee shall intimate the stock exchanges and depositories within one working day of such development.

s. Payment of debt securities or subsequent payment of defaulted Debentures

In case of receipt of intimation or subsequent intimation to the depositories regarding full payment of redemption amount or any developments that impacts the status of default of the concerned debt securities (including restructuring of debt securities, IBC proceedings, its repayment, etc.) from Issuer or from Debenture Trustee(s), transactions shall be restricted in such debt securities by the depositories immediately. The same shall be informed to the stock exchange(s) and disseminated on respective depositories' website, within one working day of such restriction. Further, the concerned Debenture Holder shall be extinguished in the depository system on receipt of corporate action documents from the issuer towards its extinguishment.

t. The process explained in paragraphs (r) and (s) above shall be followed either till full payment on these Debentures is made by Issuer or the Issuer has been liquidated and money has been realised after completion of recovery proceedings.

u. Filing Requirements

(i) Issuers shall fill all the requisite fields as provided in **Annex - XIV-A** of the SEBI Master Circular in the Centralized Database at the time of allotment of International Securities Identification Number. Depositories shall verify the information as provided by Issuer at the time of activation of International Securities Identification Number.

(ii) Post listing of securities, Issuers shall submit information in the requisite fields as provided in **Annex - XIV-B** of the SEBI Master Circular to any of the stock exchanges where their securities are listed on a periodical basis and/or 'as and when' basis (event based), as applicable. The stock exchange shall indicate the format of filing to the Issuers in this regard.

(iii) Issuer shall ensure that EBPs shall update on their websites, details of issuances done through the EBP platform at the end of the day after the acceptance of the bid by the Issuer in the format at **Annex - XV-B** of the SEBI Master Circular.

v. Information to be submitted to the Debenture holders

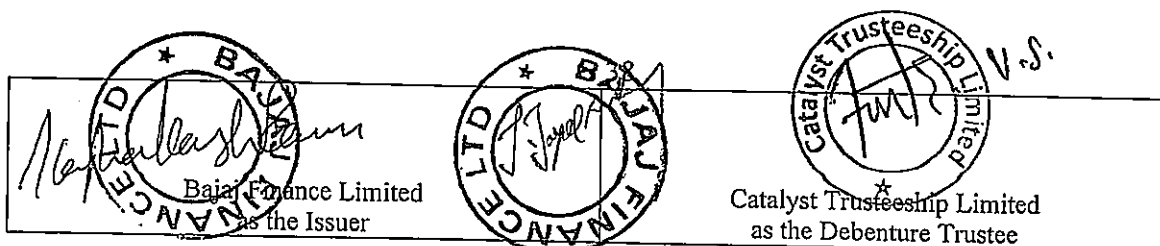

In terms of the provisions of the Regulation 58 of SEBI (Listing Obligations and Disclosure Requirements), 2015, the Company shall send to the Debenture Holders soft copies of the full annual reports to all the holders of non-convertible securities who have registered their email address(es) either with the listed entity or with any depository.

7. TERMS OF SECURITY

7.1. Continuing Security

The Security created/ to be created pursuant to this Deed shall be a continuing security and shall remain in full force and effect until the Secured Obligations are or may become outstanding. The Company hereby undertakes that during the subsistence of the Security created by the Company in favour of the Debenture Trustee, the Company shall not do or suffer to be done or be party or privy to any act, deed, matter or thing which may, in anywise prejudicially affect the Security and the rights created in favour of the Debenture Trustee.

7.2. Additional Security

For the consideration aforesaid, the Company shall within such period as may be permitted by the Trustee, furnish to the Trustee additional security, if the Trustee (acting on the instructions of the Majority Debenture Holders) is of the opinion that during the subsistence of the Debentures, the Security for the Debentures has become inadequate and the Trustee has, accordingly, called upon the Company to furnish such additional security. In such case, the Company shall, at its own costs and expenses, furnish to the Trustee such additional security in form and manner satisfactory to the Trustee as security for the Debentures, and upon creation of such additional security, the same shall vest in the Trustee subject to all the trusts, provisions and covenants contained in these presents.

7.3. Other Security

The Security created/ to be created pursuant to the Deed of Hypothecation shall be in addition and without prejudice to any other security, indemnity or other right or remedy which any Debenture Holder/Beneficial Owner or the Trustee may now or hereafter hold or have in connection with the Debentures or part thereof, and shall neither be merged in, or in any way exclude or prejudice, or be affected by any other security, right of recourse or other right whatsoever (or the invalidity thereof) which the Debenture Holder(s) or the Trustee may now or at any time hereafter hold or have (or would apart from this security hold or have) as regards the Company or any other person in respect of the Debentures. The Security may be enforced against the Company without first having recourse to any other rights of the Debenture Holder(s) or the Trustee, subject to the Company's obligation to create additional security in case of reduction in the security cover.

7.4. Method and Mode of Preservation

- a) The Company undertakes that at all times, it shall have good, legal and beneficial title, or other interest in and to the Secured Assets, in each case, free and clear of any encumbrance or Security Interest (save and except any security existing thereon or on any part thereof, as at the date hereof) and shall

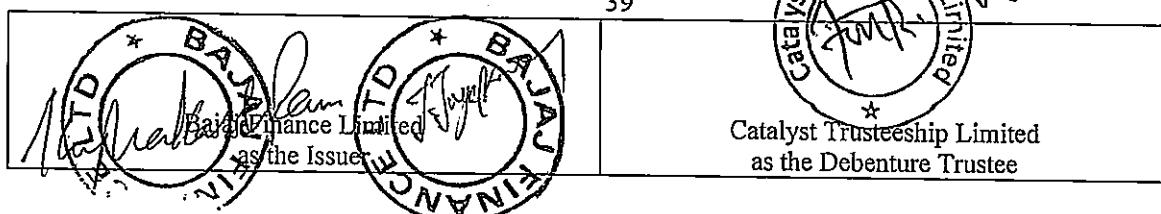

ensure on a continuous basis that the property charged to the Debentures is available and adequate at all times to discharge the Secured Obligations.

- b) The Company shall pay all such stamp duty (including any additional stamp duty, if any), other duties, Taxes, charges and penalties, if and when the Company may be required to pay according to the laws for the time being in force in the State in which the Secured Assets are situated or otherwise, and in the event of the Company failing to pay such stamp duty, other duties, Taxes and penalties as aforesaid, the Trustee will be at liberty (but shall not be bound) to pay the same and the Company shall reimburse the same to the Trustee on demand.
- c) The Company shall punctually pay all rents, royalties, Taxes, rates, levies, cesses, assessments, impositions and outgoings, governmental, municipal or otherwise imposed upon or payable by the Company, in relation to the Secured Assets, as and when the same shall become payable, and when required by the Trustee produce the receipts for such payments and also punctually pay and discharge all debts, obligations and liabilities which may have priority over the Security created hereunder or under the other Security Documents and observe, perform and comply with all covenants and obligations which ought to be observed and performed by the Company in respect of or any part of the Secured Assets.
- d) The Company shall pay all such stamp duty (including any additional stamp duty, if any), other duties, Taxes, charges and penalties, if and when the Company may be required to pay according to the laws for the time being in force in the State in which its properties are situated or otherwise, and in the event of the Company failing to pay such stamp duty, other duties, Taxes and penalties as aforesaid, the Trustee will be at liberty (but shall not be bound) to pay the same and the Company shall reimburse the same to the Trustee on demand.

7.5. Inspection

The Company shall keep proper books of account as required by the Act and make true and proper entries therein of all dealings and transactions of and in relation to the Secured Assets and the business of the Company and keep the said books of account and all other books, registers and other documents relating to the affairs of the Company at its registered office or, where permitted by law, at other place or places where the books of account and documents of a similar nature may be kept and the Company will ensure that all entries in the same relating to the Secured Assets and the business of the Company shall at reasonable times be open for inspection of the Trustee and such person or persons, as the Trustee shall, from time to time, in writing for that purpose appoint;

7.6. Further Borrowings

(In case of pari-passu charge on secured assets):

40	Catalyst Trusteeship Limited as the Debenture Trustee
----	--

(Note: The image contains two circular stamps on the left side of the table. The first stamp is for 'Bajaj Finance Limited' and the second is for 'Catalyst Trusteeship Limited'. Both stamps contain handwritten signatures and dates. The text 'Catalyst Trusteeship Limited as the Debenture Trustee' is printed below the second stamp.)

As long as the Security Coverage Ratio does not fall below the percentage / level stipulated under terms of issue, the Company shall, without the approval of the Trustee, be entitled to, to make further issue(s) of debentures, raise further loans and advances and/or avail further deferred payment guarantees or, provide corporate guarantees/comforts or avail any other financial facilities from time to time from such persons/ banks/ financial institutions or body corporate/ any other agency as it deems fit. However, subject to maintenance of security coverage ratio, the company may create charge on any of the Secured Assets, other than the Permitted Security Interest, without obtaining the prior written approval of the Majority Debenture Holders and Debenture Trustee.

7.7. Dealing with the Secured Assets

At any time before the Security constituted becomes enforceable, the Trustee may, at the cost and request of the Company, and if authorized by approval from Debenture Holders with Special Majority, do or concur with the Company in doing all or any of the things which the Company might have done in respect of the Secured Assets as if no security had been created and particularly but not by way of limitation may sell, call in, collect, convert, lease, purchase, substitute, exchange, surrender, develop, deal with or exercise any right in respect of all or any of the Secured Assets on such terms and for such consideration as the Trustee may deem fit, provided that all properties of any description and all net capital monies arising from or receivable upon any such dealing as aforesaid and remaining after payment therefrom of the costs and expenses of and incidental to such dealing shall become part of the Secured Assets and shall be paid or vested in or specifically charged in favour of the Trustee in such manner as Trustee may require.

7.8. Withdrawal of Secured Assets on Substituting other Assets

The Company shall be at liberty at any time during the continuance of these presents, with the prior permission in writing of the Trustee (acting on Majority Debenture Holders approval/instructions), to withdraw any of the Secured Assets from such of the trusts, powers and provisions hereof as exclusively relate to the Secured Assets upon substituting other assets whether of the same or greater than the value of the assets proposed to be withdrawn. The Debenture Holders shall permit the Company to withdraw any assets under this clause, if the Company proves to their satisfaction that the assets proposed to be substituted for the same is of a value equal to or greater than the value of the assets proposed to be withdrawn and that such assets are suitable for the purpose of business of the Company and upon such proof being given and with the approval of Majority Debenture Holders, the Trustee must convey or assign or cause to be conveyed or assigned such assets to the Trustee in such manner as they shall direct UPON THE TRUSTS hereof relating to the Secured Assets and thereupon the Trustee shall be at liberty to re-convey to the Company or as the Company may direct the property to be withdrawn TO HOLD the same free from such of the trusts, powers and provisions hereof as exclusively relate to the Secured Assets. The Company may as proofs submit, inter alia, (i) a certificate signed by any one of the directors of the Company to the effect that any such property purported to be substituted is in his opinion suitable for the purpose of business of the Company; (ii) a written report of a valuer appointed/ approved by them certifying the value of the property proposed to be substituted is greater than the value of the property proposed to be substituted.

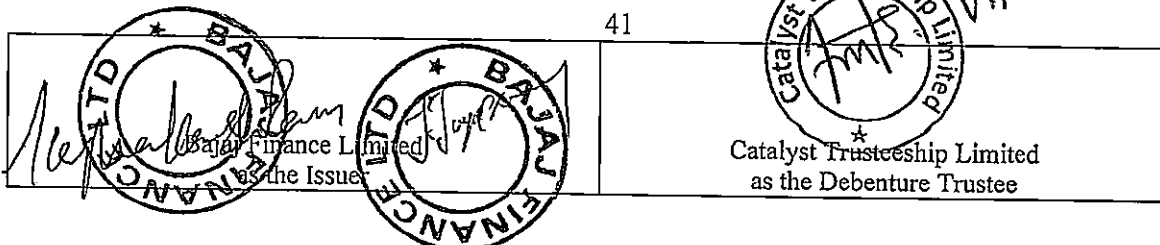

8. ENFORCEMENT AND REALISATION RELATED COVENANTS

8.1. Trust of The Secured Properties:

The Security created in favour of the Debenture Trustee shall become enforceable by the Debenture Trustee, in terms of this Deed and other Debenture Documents, upon the occurrence of an Event of Default.

On the occurrence of an Event of Default, the Debenture Trustee or their nominees shall, without any notice and without assigning any reason and at the risk and expense of the Company (and if necessary, as attorney for and in the name of the Company) and without being bound to exercise any of these powers or being liable for any losses in the exercise or non-exercise thereof, and without prejudice to any other rights and remedies the Debenture Trustee or the Debenture Holders may have, be entitled to:

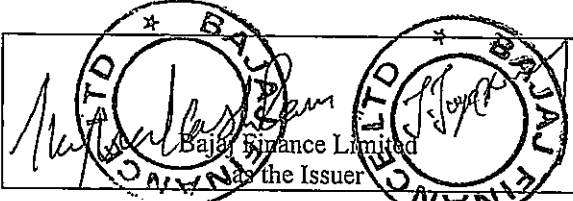
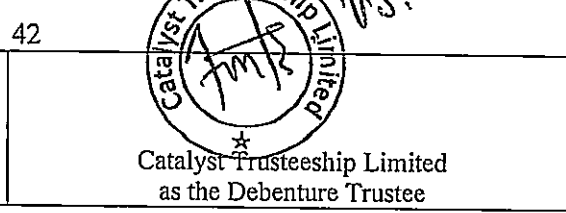

- (a) seize, recover, receive and remove the Hypothecated Property (or any of them) and/or otherwise dispose off or deal with all or any part of the Hypothecated Property and enforce, realize, settle, compromise and deal with any rights or claims relating thereto, as it deems fit;
- (b) take possession of the Hypothecated Property and after the taking of such action, the Company shall immediately deliver to the Debenture Trustee all related bills, statements, contracts and documents in relation to the Hypothecated Property, and the Company shall take no action inconsistent with or prejudicial to the right of the Debenture Trustee to quietly possess, use and enjoy the same and to receive the income, profits and benefits thereof, without interruption or hindrance by the Company or by any other Person(s) whomsoever; and upon the taking of such action, the Debenture Trustee shall be freed and discharged from, or otherwise kept well and sufficiently saved and by the Company of, from and against all former and other estates, titles, claims, demands and encumbrances whatsoever;
- (c) appoint by writing any Person(s) to be a Receiver of all or any part of the Hypothecated Property, and from time to time determine the remuneration of the Receiver and remove the Receiver (except where an order of the court is required therefor) and appoint another in place of any Receiver, whether such Receiver is removed by the Debenture Trustee (acting on the instructions of the Debenture Holders) or an order of the court or otherwise ceases to be the Receiver or one of two or more Receivers;
- (d) to make any arrangement or compromise between the Company and any other person in relation to the Hypothecated Property on such terms and conditions as the Debenture Trustee or the Receiver may consider fit;
- (e) to assign, sell, grant options to sell, deal with or manage or concur in assigning, selling, granting options to sell, or otherwise dispose of any part of the Hypothecated Property in such manner and generally on such terms and conditions as the Debenture Trustee or the Receiver shall consider fit and to carry any such transactions into effect in the name of and on behalf of the Company or otherwise;

42	
 Bajaj Finance Limited as the Issuer	 Catalyst Trusteeship Limited as the Debenture Trustee

- (f) to obtain all clearances, licenses, and permissions, approvals and any other consents or licenses necessary or appropriate to carry out any of the matters referred to in this Deed or otherwise as the Debenture Trustee or Receiver shall consider fit;
- (g) to redeem any prior Security Interest and settle and pass the accounts of the Security Interest so that any accounts so settled and passed shall (subject to any manifest error) be conclusive and binding on the Company and the money so paid shall be deemed to be an expense properly incurred by the Receiver;
- (h) to settle, refer to arbitration, compromise and arrange any claims, accounts, disputes, questions and demands with or by any person or body who is or claims to be a creditor of the Company or relating in any way to the Hypothecated Property or any part thereof;
- (i) to bring, prosecute, enforce, defend and discontinue all such actions and proceedings in relation to the Hypothecated Property or any part thereof as the Receiver shall consider fit;
- (j) insure and keep insured the property and assets of an insurable nature comprised in the Hypothecated Property against loss or damage by such risks and contingencies in such manner and in all respects as set out in the Debenture Trust Deed, and to maintain, renew or increase any insurance in respect of such property or assets;
- (k) in the exercise of any of the above powers, to expend such sums as the Receiver may think fit and the Company shall forthwith on demand (supported by evidence) repay to the Receiver all sums so expended together with the coupon thereon calculated at the average coupon rate applicable in respect of the Outstanding Amounts; and
- (l) take all such other actions (including, without limitation, signing and executing all documents and deeds) expressly or impliedly permitted under this Deed or in any other Debenture Document or under Applicable Law as may be considered by the Debenture Trustee or Receiver to be incidental or conducive to any of the matters or powers aforesaid or otherwise incidental or conducive to the preservation, improvement or realisation of the Hypothecated Property, which the Debenture Trustee or the Receiver may lawfully do in the name of the Company for all the purposes aforesaid.

The Company agrees that the aforesaid powers ("**Power of Sale**") have been granted for valuable consideration and is coupled with interest and as such shall be irrevocable in nature for so long as any part of the Secured Obligations remains due owing or payable.

It is clarified that the Debenture Trustee is entitled though not bound to exercise the aforesaid rights or powers and any such exercise shall be without prejudice to the other rights and remedies of the Debenture Trustee and/ or the Debenture Holders. The Debenture Trustee shall not be liable for any loss caused in the exercise of rights or powers hereunder and all such loss shall be wholly to the account of the Company, howsoever the same may have been caused, and shall be borne by the Company. If

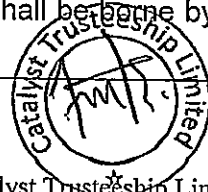
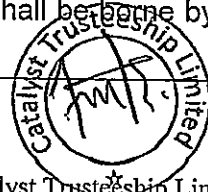
  Catalyst Finance Limited as the Issuer	43	  Catalyst Trusteeship Limited as the Debenture Trustee
---	----	--

the Debenture Trustee and/or the Debenture Holders suffer any losses in relation to the aforesaid then all amounts consisting of such losses shall, if not paid on demand to the Debenture Trustee and/ or the Debenture Holders by the Company, be payable along with the Default Interest from the date of demand until the date of repayment by the Company and shall form part of the Secured Obligations.

All the powers and provisions contained in or implied by these presents shall, notwithstanding anything contained herein or arising by virtue thereof or except in consultation with the Trustee, be subject to and *pari passu* with those of the Existing Encumbrances and the same shall not be exercised or enforced by the Trustee hereunder so as to in anyway prejudice the rights and interests of the existing chargeholders under their existing securities and except with the prior approval and consent of the existing chargeholders.

8.2. Trust of Proceeds of Sale/ Realisation out of The Secured Assets

The Trustee shall hold UPON TRUST the monies, received by them or the Receiver in respect of the Secured Assets or any part thereof arising out of:

- (a) any sale, calling in, collection or conversion under the Power of Sale;
- (b) income, rent or profits arising in respect of the Secured Assets;
- (d) compensation money in respect of any acquisition and requisition or nationalisation or take-over of the management of the Company;
- (e) any other realisation whatsoever;

and they shall, in the first place, by and out of the said monies, reimburse themselves and pay, retain or discharge all the costs, charges and expenses incurred in or about the entry, appointment of Receiver, calling in, collection, conversion or the exercise of the powers and trusts under these presents, including their, and the Receiver's remuneration as herein provided, and shall apply the residue of the said monies subject to the rights of the mortgagee as may be provided in a separate arrangement to be entered into between them and the Trustee:

FIRSTLY in or towards payment to the Debenture Holder(s)/ Beneficial Owner(s), *pari passu*, of all arrears of interest including compound interest (which shall be deemed to accrue due from day to day) remaining unpaid on the Debentures held by them;

SECONDLY in or towards payment to the Debenture Holder(s)/ Beneficial Owner(s), *pari passu*, of all principal amounts together with redemption premium, if any, owing on the Debentures held by them and whether the said principal amounts together with redemption premium, if any, shall or shall not then be due and payable; and

THIRDLY in or towards payment of the surplus (if any) of such monies to the person or persons entitled thereto:

Provided that, if the Trustee acting on the instructions of the Majority Debenture Holder(s), is of the opinion that it is expedient to do so, payments may be made on account of principal together with redemption premium, if any, before the whole or part of the interest due on the Debentures has been paid off, but such alteration in the order of payment of principal together with redemption premium, if

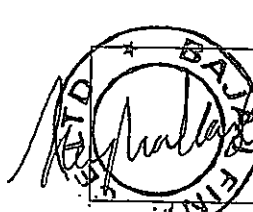
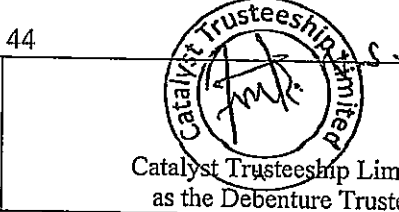
 Bajaj Finance Limited as the Issuer	44	 Catalyst Trusteeship Limited as the Debenture Trustee
---	----	--

any, and interest herein prescribed shall not prejudice the right of the Debenture Holder(s)/Beneficial Owner(s) to receive the full amount to which they would have been entitled if the ordinary order of payment had been observed or any less amount which sum ultimately realised from the security may be sufficient to pay.

The Trustee shall not be affected by any notice, express or implied, of the right, title or claim of any Person to the said monies other than the Debenture Holder(s).

8.3. Power to Accumulate Proceeds

If, the amount of the monies at any time apportionable under Clause 8.2 hereof shall be less than 10% (ten percent) of the nominal amount of the Debentures then outstanding, the Trustee may, at their discretion, invest such monies in any one of the Authorised Investments herein authorised with power, from time to time, at its discretion to vary such investments and such investments with the resulting income thereof may be accumulated until the accumulations together with any other fund for the time being under the control of the Trustee and available for the purpose shall amount to a sum sufficient to pay 10% (ten per cent) of the Debentures then outstanding and the accumulations and funds shall be applied in the manner aforesaid. Provided that the Trustee shall not be liable for any loss which may be occasioned by any investment or variation thereof made by them pursuant to this Clause.

8.4. Investment of Capital Monies

Subject as aforesaid, the Trustee shall invest the net capital monies referred to in Clauses 8.2 and 8.3 above, upon some or one of the Authorised Investments or place the same upon deposit or in current account in the name of the Trustee with any scheduled bank or banks with power from time to time to vary such investments and with power from time to time at their discretion to resort to any such investments for any of the purposes for which such proceeds are under these presents authorised to be expended. Provided however that any such monies including the Authorised Investments shall be held by the Trustee solely in trust for the benefit of the Debenture Holder(s).

8.5. Authorised Investments

Any monies which are under the trust or powers herein contained ought to be invested by the Trustee may be invested in the name of the Trustee in any of the investments by law authorised for investment of Trust monies for the time being in force in India ("**Authorised Investments**") with power to vary and transpose such investments and in so far as the same shall not be invested shall be placed on deposit in the name of the Trustee in scheduled bank or banks.

8.6. Notice Before Payment

The Trustee shall give not less than 14 (fourteen) days' notice to the Debenture Holder(s)/Beneficial Owners(s) under Clauses 8.2 and 8.3 hereof and after the day so fixed, the Debenture Holder(s)/Beneficial Owners(s) of each outstanding Debenture shall be entitled to interest on the balance only (if any) of the principal moneys due on such Debentures held by them after deducting the amount (if any) payable in respect of the principal thereof on the day so fixed.

45

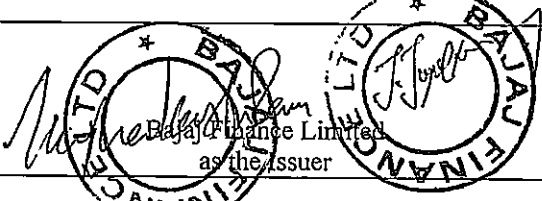
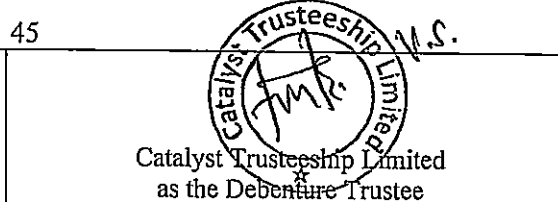
 Catalyst Finance Limited as the Issuer	 Catalyst Trusteeship Limited as the Debenture Trustee
--	--

8.7. Memorandum of Part Satisfaction

Upon any payment under Clause 8.2 and 8.3 above, not amounting to complete payment of all principal amounts and interest due thereon, the Debentures in respect of which payment is made shall be produced to the Trustee who shall cause a memorandum of the amount and date of payment to be endorsed thereon. The Trustee may, in their discretion, dispense with the production and endorsement of Debentures as aforesaid, in any special case upon such indemnity as the Trustee may think fit.

8.8. Receipt of Debenture Holder(s)

The receipt of each holder/owner of the Debentures (s) or if there be more than one holder(s)/owner(s) of any such Debentures, then the receipt of any one of such holder(s)/owner(s) or of the survivors or survivor for the principal monies and interest payable in respect of each of such Debenture shall be a good discharge to the Trustee.

8.9. Purchasers and Persons dealing with Trustee Not Put on enquiry

No purchaser or other person dealing with the Trustee or any Receiver appointed by them or their attorneys or agents shall be concerned to inquire whether the power exercised or purported to be exercised has become exercisable or whether any money remains due on the Security or as to the necessity or expediency of the stipulations and conditions subject to which any sale shall have been made or otherwise as to the propriety or regularity of any sale, calling in, collection or conversion or to see to the application of any money paid to the Trustee or Receiver and in the absence of *mala fides* on the part of such purchaser, mortgagor, mortgagee or other person such dealing shall be deemed, so far as regards the safety and protection of such person, to be within the powers hereby conferred and be valid and effectual accordingly and the remedy of the Company or its assigns in respect of any impropriety or irregularity whatsoever in the exercise of such power shall be in damages only.

8.10. Receipt of Trustee to be Effectual Discharge

Upon any such sale, calling in collection or conversion as aforesaid and upon any other dealing or transaction under the provisions herein contained the receipt of the Trustee for the purchase money of any of the Secured Assets sold and for any other monies paid otherwise howsoever to them shall effectually discharge the purchaser or purchasers or person paying the same there from and from being concerned to see to the application or being answerable for the loss or misapplication or non- application thereof.

8.11. Application To Court

The Trustee may at any time after the security constituted becomes enforceable apply to the Court for an order that the powers and trusts hereof be exercised and carried into execution under directions of the Court and for the appointment of a Receiver(s) and manager of the Secured Assets or any of them and for any other order in relation to the execution and administration of the powers and trusts hereof as the Trustee

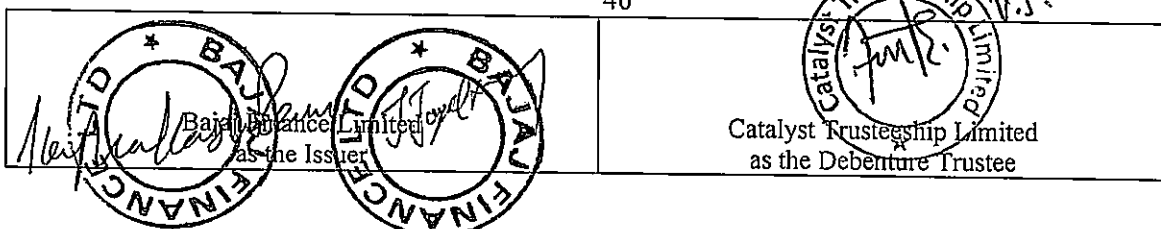

shall deem expedient and they may assent to or approve of any application to the Court made at the instance of any of the Debenture Holder(s)/Beneficial Owner(s).

9. MISCELLANEOUS

9.1 The Trustee shall concur with the Company in making any modifications to, or waiver in these presents which in the opinion of the Trustee shall be expedient to make; provided that the modification/ waiver has been approved in writing by Majority Debenture Holders, the Trustee shall give effect to the same by executing necessary supplemental deed(s) to these presents.

9.2 NOTICES

Any notice, demand, request or other communication to be made or given under this Deed shall be in writing unless otherwise stated at the following addresses. Such notice, demand request or other communication shall be deemed to have been duly given or made when it shall be sent by any of the following means: (a) delivered personally, or (b) sent by registered mail with acknowledgment due, postage prepaid, or (d) sent by e-mail. The address for service of each of the Parties are as follows-

For Debenture Trustee

CATALYST TRUSTEESHIP LIMITED,
GDA House, Plot No. 85,
Bhusari Colony (Right),
Kothrud, Pune-411038
Kind Attn: Mr. Umesh Salvi
Phone: 020-6680200
Email: ComplianceCTL-Mumbai@ctltrustee.com

For Company

Bajaj Finance Limited
3rd Floor, Panchshil Tech Park
Viman Nagar, Pune 411014
Kind Attn: Mr. R Vijay, Company Secretary
Phone: 020 71576403
Email: vijay.r@bajajfinserv.in

9.3.1 Any communication or document made or delivered by one person to another under or in connection with this Deed will only be effective:

- a) if by way of personal delivery, when delivered; or
- b) if by way of letter, 3 (three) Business Days after it has been deposited in the post (by registered post, with acknowledgment due), postage prepaid in an envelope duly addressed to the addressee; or
- c) if by way of e-mail, when received in legible form.

9.3.2 Notwithstanding anything to the contrary contained hereinabove, any communication

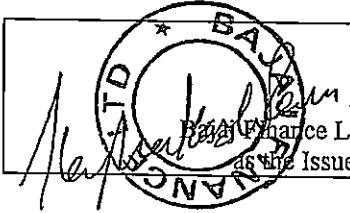
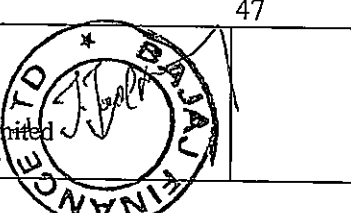

47

 <p>Bajaj Finance Limited as the Issuer</p>	 <p>Catalyst Trusteeship Limited as the Debenture Trustee</p>	
--	--	--

or document to be made or delivered to the Debenture Trustee or the Company will be effective only when actually received by the Debenture Trustee or the Company, as the case may be.

- 9.3.3 Any notice given under or in connection with any Transaction Document must be in English.
- 9.3.4 Any Party to this Deed may modify or alter the details for notices to be served on such Party, by giving a prior written notice of 5 (five) Business Days, addressed to all other Parties.
- 9.3.5 Any notice, demand, request or other communication may be served by the Company or the Trustee upon the holder(s)/owner(s) of any debentures issued under these presents by way of e-mail at their addresses provided by the Company or sending through post in prepaid letter addressed to such Debenture Holder(s)/ Beneficial Owner(s) at their registered address and any notice, demand, request or other communication so sent by email or post, shall be deemed to have been duly served on receiving a delivery notification of the email or the third day following the day on which it is posted and in proving such service it shall be sufficient to prove that the letter containing the notice was properly addressed and put into post box.
- 9.3.6 Where a document is sent by post, service thereof shall be deemed to be effected by properly addressing and prepaying and posting a letter containing the document provided that if intimation has been given in advance that the documents should be sent under a certificate of posting or by registered post with or without acknowledgement due and a sum sufficient to defray the expenses has been deposited, service of the document shall not be deemed to be effected unless it is sent in the manner so intimated by the Debenture Holder(s)/ Beneficial Owner(s).
- 9.3.7 Any communication made to the Debenture Holders under the provisions of this Deed or any other Transaction Documents by the Trustee may be made by electronic media, press-release and placing notice on its website.
- 9.3.8 E-Mail Indemnity:
- a) The Company understands and acknowledges that there are inherent risks involved in sending the instructions / communications / documents to the other Parties via emails and hereby agrees and confirms that all risks shall be fully borne by the Company and the Company assumes full responsibility for the same.
 - b) The Company shall not hold the Trustee liable for any losses or damages including legal fees arising upon the Trustee performing or non-performing or any delay /default in performing any act, wholly or in part in accordance with the instructions so received which could be a result of any fraudulent alterations and incorrect transmissions beyond the control of the Trustee considering the mode in which the same was conveyed.
 - c) The Trustee shall not be bound to act in accordance with the whole or any part of the instructions or directions contained in any email and may in its sole discretion and exclusive determination, decline or omit to act pursuant to any such instruction, or defer acting in accordance with any such instruction if the

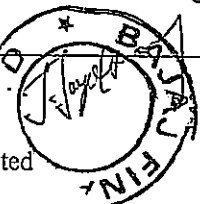
48

  Rajat Finance Limited as the Issuer	 Catalyst Trusteeship Limited as the Debenture Trustee
--	--

Trustee has doubts about the contents, authorization, origination of the said instruction or if the Trustee is of the view that the said instruction has been fraudulently sent or mistakenly written and sent or has been altered and sent and the same shall be at the Company's risk and the Trustee shall not be liable for the consequences of any such refusal or omission to act or deferment of action; and

- d) The Company agrees to indemnify the Trustee for any causes, actions, claims, damages, liabilities etc. that may arise out of acting under such email instructions fraudulently transmitted or incorrectly altered, which are finally judicially determined in the competent Court of law.

9.3 ASSIGNMENT

This Deed shall be binding upon and ensure to the benefit of each Party hereto and its or any subsequent successors and assigns. The Company shall not be permitted to assign or transfer any of its rights, liabilities and/or obligations under this Deed or under any other Transaction Documents unless approved by the Debenture Trustee and/or Majority Debenture Holders.

9.4 RIGHTS OF THE DEBENTURE HOLDERS

Notwithstanding anything to the contrary contained elsewhere, in the event the Debenture Holders are unable to exercise any rights available to it under this Deed and/or under any other Transaction Documents in full owing to any Applicable Law or regulation in force, then the Debenture Holders shall be entitled to the exercise of any such right under this Deed and/or any other Transaction Documents to the limited extent permissible under Applicable Law.

9.5 TAX GROSS-UP AND INDEMNITY

- (a) All payments to be made by the Company to the Debenture Trustee under the Transaction Documents (including any fees payable) shall be made free and clear of and without any Tax Deduction unless the Company is required to make a Tax Deduction under any Applicable Law.
- (b) The Company shall promptly upon becoming aware that there is any change in the rate or the basis of a Tax Deduction notify the Debenture Trustee accordingly. Similarly, the Debenture Trustee shall notify the Company on becoming so aware in respect of a payment payable to the Debenture Trustee.
- (c) If the Company is required to make a Tax Deduction, the Company shall make that Tax Deduction and any payment required in connection with that Tax Deduction within the time allowed and in the minimum amount required under Applicable Law.
- (d) Within the time permitted under Applicable Law of making either a Tax Deduction or any payment required in connection with that Tax Deduction, the Company shall, if requested by the Debenture Trustee, deliver to the Debenture Trustee evidence reasonably satisfactory to the Debenture Trustee that the Tax Deduction has been made or (as applicable) any appropriate payment paid to the relevant Tax authority.

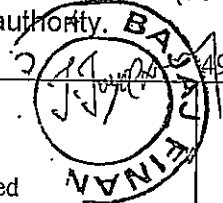
 Finance Limited as the Issuer	 Catalyst Trusteeship Limited as the Debenture Trustee
---	---

- (e) Without prejudice to the provisions hereof, if the Debenture Holder(s) or the Debenture Trustee are required to make any payment on account of Taxes (not being Taxes imposed on or calculated by reference to the net income paid to and received by any of them) or otherwise on or in relation to any sum received or receivable hereunder by the Debenture Holder(s) or the Debenture Trustee or any liability in respect of any such payment is asserted, imposed, levied or assessed against the Debenture Trustee / Debenture Holder(s), the Company shall, upon demand, promptly indemnify and pay to the Debenture Trustee / Debenture Holder(s) against such payment or liability, together with any interest, penalties, costs and expenses payable or incurred in connection therewith.
- (f) The Debenture Trustee shall be indemnified by the Company against all costs, charges and expenses incurred for or in relation to any such application or proceeding.

9.6 FURTHER ASSURANCES

The Company agree to do all such further and other things, execute and deliver all such additional documents, to give full effect to the terms of this Deed. The Parties undertake that they will do or procure to be done all such further acts and things, execute or procure the execution of all such other documents and exercise all rights and powers available to it in relation to any Person so as to ensure the fulfilment, observance and performance of all the provisions of this Deed and generally that full effect is given to the provisions of this Deed.

9.7 PARTIAL INVALIDITY

If, at any time, any provision of this Deed or any other Transaction Documents is or becomes illegal, invalid or unenforceable in any respect under any Applicable Law, neither the legality, validity or enforceability of the remaining provisions, to the extent severable, nor the legality, validity or enforceability of such provision under the law of any other jurisdiction will in any way be affected or impaired.

9.8 REMEDIES AND WAIVERS

No failure to exercise, nor any delay in exercising, on the part of the Debenture Trustee, any right or remedy in accordance with the Transaction Documents upon the occurrence of an Event of Default in accordance with the Transaction Documents shall operate as a waiver, nor shall any single or partial exercise of any right or remedy prevent any further or other exercise or the exercise of any other right or remedy. The rights and remedies provided in this Deed are cumulative and not exclusive of any rights or remedies provided by law.

9.9 GOVERNING LAW AND JURISDICTION

This Deed is governed by and shall be construed in accordance with the laws of India.

The Parties agree that the courts and tribunals in Chennai shall have exclusive jurisdiction to settle any disputes which may arise out of or in connection with this Deed. The Trustee may however in the absolute discretion commence any legal

50

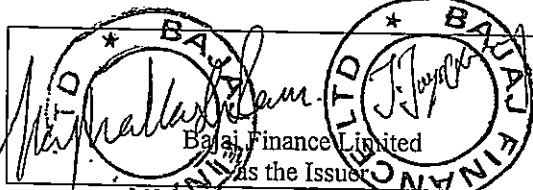
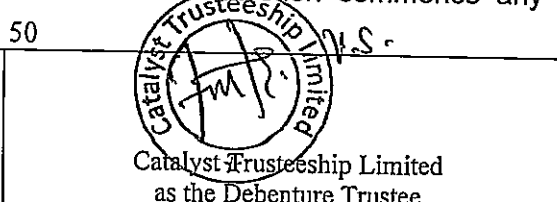
 <p>Balaji Finance Limited as the Issuer</p>	 <p>Catalyst Trusteeship Limited as the Debenture Trustee</p>
---	---

action or proceeding arising out of this Deed in a Court, tribunal or any other appropriate forum in India and the Company hereby consents to that jurisdiction.

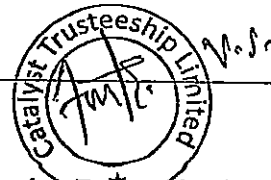
 Bajaj Finance Limited as the Issuer	51	 Catalyst Trusteeship Limited as the Debenture Trustee
---	----	--

PART – B OF THE DEBENTURE TRUST DEED

10. ISIN RELATED AND FINANCIAL COVENANTS AND CONDITIONS:

10.1. Issue Opening Date

Issue Opening Date shall mean the date as specified in respective Key Information Document.

10.2. Issue Closing Date

Issue Closing Date shall mean the date as specified in respective Key Information Document.

10.3. Pay in Date

The Pay in Date shall mean the date as specified in respective Key Information Document.

10.4. Deemed Date of Allotment/ Date of Allotment

The Deemed Date of Allotments shall mean as mentioned in respective Key Information Document.

10.5. Conditions Precedent to Disbursement

As mentioned in respective Key Information Document.

10.6. Condition Subsequent to Disbursement

As mentioned in respective Key Information Document.

10.7. Risk factors pertaining to the issue of the Debentures shall be as specified in respective Key Information Document.

10.8. Debentures to rank “pari passu”

The Debentures issued under these presents shall rank pari passu inter se without any preference or priority of one over the other or others of them.

10.9. Interest:

Interest shall be as specified in respective Key Information Document.

Whenever any coupon payment date (other than the ones falling on each Redemption Date) falls on a day other than a Business Day, such payment shall be made on the immediately following Business Day, which becomes the coupon payment date for that coupon without changing the coupon payment date for subsequent payment obligations of coupon.

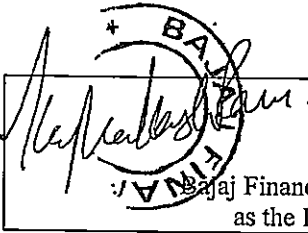
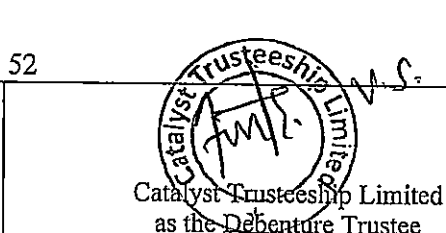
 Sajaj Finance Limited as the Issuer	52	 Catalyst Trusteeship Limited as the Debenture Trustee
---	----	--

No interest / interest on interest shall accrue on the Debentures after the date of maturity of the respective instruments.

- (a) The interest shall be payable by the Company in accordance with the provisions of this Deed.
- (b) PROVIDED ALWAYS AND IT IS HEREBY AGREED AND DECLARED that all interest which shall accrue on the outstanding Debentures or any part thereof and for the time being remaining unpaid and all other monies which have become payable under these presents shall in case the same be not paid on the dates on which they accrued due, carry compound interest at monthly rests, at the aforesaid rate will become due and payable over the monies due for the period of default.
- (c) PROVIDED FURTHER THAT the Debentures shall carry additional interest of atleast 2% (two percent) per annum over and above interest rate payable monthly/quarterly/half yearly on the Debentures from the Deemed Date of Allotment till creation of security in accordance with the General Information Document/Key Information Document/ Disclosure Documents/Prospectus, to the satisfaction of the Trustee or the Debenture Holder(s)/Beneficial Owners(s), if the security is not created within stipulated timeline as per Applicable Law.
- (d) PROVIDED HOWEVER, in the event of any default in the payment of interest and/or in the redemption of the Debentures and all other monies payable pursuant to this Deed read with the General Information Document/Key Information Document/ Disclosure Documents/Prospectus, the Company shall pay to the holder/s of the Debentures, further interest at the rate of 2% (two percent) per annum over the interest rate for the default in payment of interest, additional interest and/or principal amount till the dues are cleared.
- (e) Notwithstanding anything to the contrary in any other provision of the Agreement, the penal interest as stated above shall not be considered for the calculation of overall return to the Debenture Holder(s).

10.10. Transaction specific Financial Covenants and Conditions as specified in the respective Key Information Document.

10.11. Redemption:

The Company hereby covenants with the Trustee that the Company shall redeem the Debentures on maturity i.e., as mentioned in the respective Key Information Document.

Whenever any Redemption Date falls on a on a day other than a Business Day, the Redemption amount shall be paid by the Company on the immediately preceding Business Day which becomes the new Redemption Date, along with interest accrued on the Debentures until but excluding the date of such payment.

10.12. Record Date

Record Date shall mean in relation to any date on which any payments are scheduled to be made by the Company to the Debenture Holder(s) in terms of this Deed and the

53

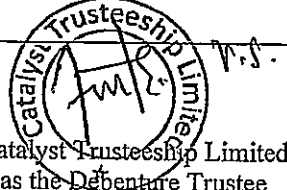
 Bajaj Finance Limited as the Issuer	 Catalyst Trusteeship Limited as the Debenture Trustee
---	--

Information Memorandum (including the coupon payment date and the Redemption Date), the day falling 15 (fifteen) calendar days prior to such date. In the event the Record Date falls on a day, which is not a Business Day, in such case the immediately preceding Business Day shall be considered as Record Date.

10.13. Put Option/Call option:

As specified in the respective Key Information Document.

10.14. Premature Redemption:

In case the Company fails for any reasons to utilize the proceeds for the Purpose, as specified in the General Information Document/Key Information Document/ Offer Letter/ Prospectus/ Disclosure Document, the Debenture Holder(s)/Beneficial Owner will be entitled to rescind/avoid the contract on that ground and to call back the money, if any paid towards subscription of the Debentures.

10.15. Appropriation of payment:

- (a) Payment of the principal amount of each of the Debentures and interest and other monies payable thereon shall be made to the respective Debenture Holder and in case of joint Debenture Holders, to the one whose name stands first in the Register of Debenture Holder(s)/list of Beneficial Owner(s) as the case may be. Such payments shall be made by real time gross settlement, cheque or warrant drawn by the Company on its bankers.
- (b) Notwithstanding anything to the contrary stated in the Transaction Documents, any payments by the Company under the Transaction Documents shall be appropriated in the following manner, namely:
 - (i) Firstly, towards meeting any costs, charges and expenses and other monies incurred by the Debenture Trustee as also the remuneration payable by the Company to the Debenture Trustee;
 - (ii) Secondly, towards default interest and compound interest as maybe due and payable under the terms of the Transaction Documents;
 - (iii) Thirdly, towards interest payable on the Debentures;
 - (iv) Fourthly, towards redemption premium, if any; and
 - (v) Lastly, towards redemption of principal amount of the Debentures due and payable by the Company to the Debenture Holder(s)/Beneficial Owner(s).

If any amount whether redemption or interest, paid to the Debenture Holder(s) in respect of the Debentures is held to be void or set aside on the liquidation or winding up of the Company or otherwise, then for the purpose of this Deed such amount shall not be considered to have been paid.

10.16. Security:

The Secured Obligations, including the redemption of the principal amount of the Debentures, payment of all interest, redemption premium, if any, remuneration of the Trustee, liquidated damages and all fees, costs, charges, expenses and other monies

54

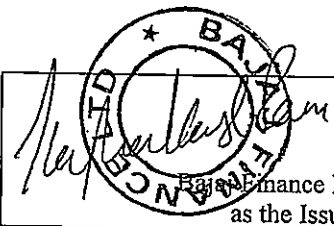
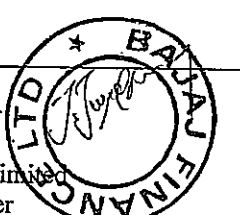
 Rajan Finance Limited as the Issuer	 Catalyst Trusteeship Limited as the Debenture Trustee	
---	---	--

payable by the Company in respect thereof shall be secured by securities specified in Clause 11 of this Deed.

The Company shall furnish to the Debenture-holder(s)/Beneficial Owner(s) copies of Security Documents evidencing the creation of complete Security as stipulated in this Deed and shall procure and furnish suitable letter from the Debenture Trustee to the effect.

10.17. Debenture Holder(s)/Beneficial Owner(s) not entitled to shareholders rights

The Debenture Holder(s)/Beneficial Owner(s) will not be entitled to any of the rights and privileges available to the shareholders including right to receive notices or annual reports or to attend and vote at general meetings of the members of the Company.

10.18. Subject to Applicable Laws, the rights, privileges, terms and conditions attached to the Debentures may be varied, modified or abrogated with Special Resolution: provided that nothing in such consent or resolution shall be operative against the Company where such consent or resolution modifies or varies the terms and conditions governing the Debentures and the same are not acceptable to the Company.

10.19. Repurchase and re-issue of Debentures

Subject to Applicable Law, the Company will have the power exercisable at its absolute discretion from time to time to repurchase some or all the Debenture(s) at any time prior to the Final Redemption Date. The Debentures which are in dematerialized form, can be repurchased by the Company through its beneficiary demat account as per the norms prescribed by the Depository. This right does not construe a call option. In the event of the Debenture(s) being bought back, or redeemed before maturity in any circumstance whatsoever, the Company shall be deemed to always have the right, subject to the provisions of the Act, to re-issue such debentures either by re-issuing the same debenture(s) or by issuing other debentures in their place.

The Company may also, at its discretion, at any time purchase Debenture(s) at discount, at par or at premium in the open market. Such Debenture(s) may, at the option of Company, be cancelled, held or resold at such price and on such terms and conditions as the Company may deem fit and as permitted by law.

10.20. Appointment of Nominee Director or Observer

(a) The Borrower agrees that the Debenture Trustee shall have the right to appoint and remove (at their discretion) from time to time a non-executive director or directors on the Board, under this Agreement (the "Nominee Director"). The power of the Debenture Trustee to appoint Nominee Director shall also include the power to appoint (and remove) an observer ("Observer") in place of such Nominee Director. Appoint a Nominee Director on the board of the company in the event of:

- a. Two consecutive defaults in payment of interest to the debenture holders; or
- b. Default in creation of security for debenture; or

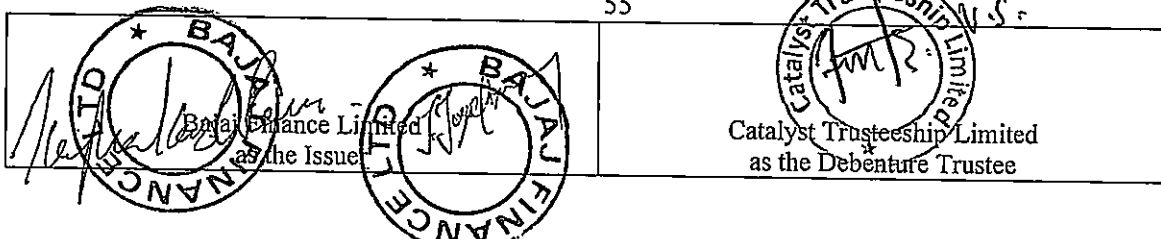

c. Default in redemption of debenture.

The Issuer company shall appoint nominee director within 01 (one) calendar month after receiving nomination notice from the debenture trustee.

- (b) The Nominee Director/ Observer shall not be required to hold qualification shares and not be liable to retire by rotation.
- (c) The Nominee Director shall be entitled to all the rights and privileges of other non-executive directors and the sitting fees, expenses as payable to other directors on the Board and any other fees, commission, monies or remuneration in any form payable to the non-executive directors, which shall be to the account of the Company.
- (d) The expenditure incurred in connection with the appointment or directorship (including the cost of attending any meetings) of the Nominee Director/ Observer shall be borne by the Company.
- (e) If so desired by the Debenture Holders, the Nominee Director shall also be appointed as a member of any committee of the Board.
- (f) The Nominee Director/ Observer(s) shall be entitled to receive all notices, agenda, etc. and to attend all general meetings of the shareholders of the Company, board meetings and meetings of any committees of the Board of the Company, if he is a member.
- (g) If, at any time, a Nominee Director/ Observer is not able to attend a meeting of the Board, or any committee/ sub-committee, if any, of which he is a member, the Debenture Trustee may depute an observer to attend the meeting. The expenses incurred in this connection shall be reimbursed by the Company.
- (h) The Nominee Director or the Observer, as the case may be, may furnish to the Debenture Trustee a report of the proceedings of all such meetings.
- (i) The appointment / removal of the Nominee Director/ Observer shall be by a notice in writing by the Debenture Trustee addressed to the Company and shall (unless otherwise indicated by the Lenders) take effect forthwith upon such a notice being delivered to the Company.
- (j) The Nominee Director or the Observer, as the case may be, shall have the right to provide information regarding the Company, that is in the Nominee Director's or Observers' discretion, relevant for the purposes of this Deed.
- (k) The Company agrees that the Nominee Director or the Observer shall not be liable for any act or omission of the Company.
- (l) The Company hereby agrees to hold the Nominee Director or the Observer harmless and to indemnify the Nominee Director or the Observer from and against any and all expenses, liabilities and losses incurred or suffered by the Nominee Director or the Observer, in connection with any action, suit or proceeding, whether civil, criminal, administrative or investigative, asserted against, imposed upon, or incurred or suffered by the Nominee Director, the

56

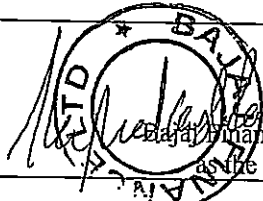
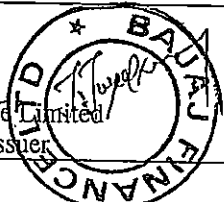
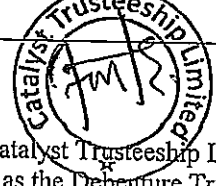
 Catalyst Finance Limited as the Issuer	 Catalyst Finance Limited as the Issuer	 Catalyst Trusteeship Limited as the Debenture Trustee
--	--	--

Observer (including attorney's fees and expenses), directly or indirectly, resulting from, based upon, arising out of or relating to the appointment of the Nominee Director or Observer. The indemnification as provided by this provision or any law for the time being in force, shall not be deemed exclusive of any other rights to which the Nominee Director, the Observer may be entitled under any provision of law, or any other agreement, or otherwise.

11. SECURITY FOR THE DEBENTURES

- 11.1 The Debenture Trustee (acting for the benefit of the Debenture Holders) shall hold the Security created by the Company under or in terms of the Transaction Documents, in its favour, upon trust, subject to the powers and provisions contained herein, for securing the Secured Obligations.
- 11.2 The Debentures and all the Secured Obligations shall be secured by first ranking pari-passu charge on the Hypothecated Property. No permission / consent would be required from the Debenture Holders / Debenture Trustee to assign / securitise any Receivables, subject to maintenance of the minimum Security Coverage Ratio, mentioned in respective Key Information Document, throughout the tenor of the Debentures.
- 11.3 The Company hereby declares that it has obtained no objection certificates/ permission, where required, in terms of the existing transaction documents from all the existing charge holders agreeing to cede pari-passu charge on Secured Assets of the Company to secure the Debentures.
- 11.4 The Company shall ensure that the requisite security cover shall not be less than 1.00 time to the Secured Obligations shall be maintained throughout the Tenor of the Debentures and this Deed.
- 11.5 The Company shall create the security set out in Clause 11.2 above prior to listing application of the Debentures. Further, the charge created by Issuer shall be registered with Sub-registrar, Registrar of Companies, CERSAI, Depository etc., as applicable, within 30 days of creation of such charge. In case the charge is not registered anywhere or is not independently verifiable, then the same shall be considered a breach of covenants/ terms of the issue by the Issuer
- 11.6 In the event that the Company fails to create and perfect a valid security on the terms set out in this Deed and other Transaction Documents within relevant time period set out, the Company shall be required to either (i) refund the entire subscription amount, or (ii) pay an interest of at least 2% (two percent) per annum over and above the coupon rate of as specified in the respective Key Information Document on the amounts outstanding on the Debenture, until the security is created and perfected in the manner and on the terms set out in this Deed and other Transaction Documents. The Company also agrees to promptly disseminate and disclose information pertaining to failure to create security, on the assets, on its website.

11.7 GRANT, CONVEY AND TRANSFER

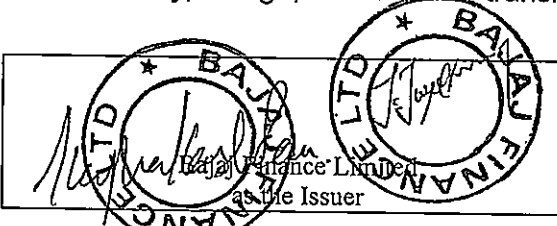
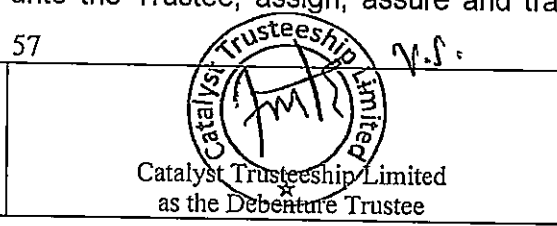

For the consideration aforesaid and as continuing security for the Secured Obligations hereby secured or intended to be hereby secured, the Company doth hereby grant, convey, assign, assure and transfer unto the Trustee, assign, assure and transfer

57

 <p>Catalyst Finance Limited as the Issuer</p>	 <p>Catalyst Trusteeship Limited as the Debenture Trustee</p>
---	---

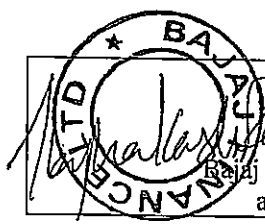
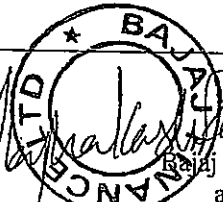

unto and in favour of the Debenture Trustee by way of a **first pari-passu charge**, all rights, titles, interests, benefits, claims and demands whatsoever of the Company in, to, and in respect of **all present and future** book debts and other debts, receivables, revenues, claims and choses-in-action of whatsoever nature and howsoever and wherever arising due or owing to or become due or owing to or acquired by the Company relating to / arising from the Hypothecated Properties including but not limited to deposits and all claims for damages and other remedies for non-payment of the same or any encumbrance of whatsoever nature, arising howsoever may at any time hereafter during the continuance of the security become due and owing to or acquired by the Company in the course of its business and the full benefit of all rights and remedies relating thereto more particularly described in the **First Schedule** written hereinunder (collectively, the "**Hypothecated Property**") TO HAVE AND TO HOLD all and singular the Hypothecated Property as security for the Debenture Trustee unto and to the use of the Debenture Trustee upon trust and for the benefit of the Debenture Holder(s)/Beneficial Owner(s).

The Company undertakes that all Security Documents, when executed, delivered and registered (where necessary) and when appropriate forms are filed as required under Applicable Law, shall create the Security expressed to be created thereby over the assets referred therein.

  Rajaj Finance Limited as the Issuer	58	  Catalyst Trusteeship Limited as the Debenture Trustee
--	----	--

THE FIRST SCHEDULE ABOVE REFERRED TO
(Description of the Secured Assets)

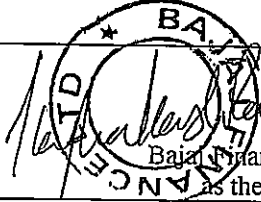

All those book-debts and receivables due to the Company under various loans, (Receivables under Financing Activity, Current Assets and Receivables, Cash and Bank Balance, Current investment, Advance recoverable, (Provided that this shall not include Permitted security interest and shall not include any investment made by the Company in unencumbered approved securities invested pursuant to Section 45-IB of the Reserve Bank of India Act, 1934) on first pari-passu basis with Banks which granted working capital limits and / or term loan to the company and the debenture-holders.

 Bajaj Finance Limited as the Issuer	59	 Catalyst Trusteeship Limited as the Debenture Trustee
---	----	--

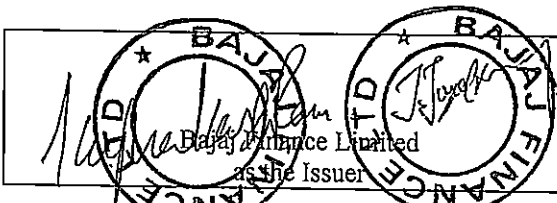

THE SECOND SCHEDULE ABOVE REFERRED TO
(Procedure to be followed for Debentures issued in
Electronic (Dematerialized)/Demat Form)

1. The Beneficial Owner(s) will intimate their relevant DP/client ID and beneficiary demat account number to the Company. The Debentures in the dematerialized form will be credited to such beneficiary demat account of the Beneficial Owner(s) in accordance with a separate agreement entered into by the Company with the Depository, under advice to them.
2. The Company has made depository arrangements with the Depository as the case may be for dematerialization of the Debentures. The investor has to necessarily hold the Debentures in dematerialized form and deal with the same as per the provisions of Depositories Act, 1996 (as amended from time to time). The normal procedures followed for transfer of securities held in dematerialized form shall be followed for transfer of these Debentures held in electronic form.
3. These Debentures are issued in the dematerialized mode and therefore every eligible applicant should apply only if they have a depository account with any of the depositories. Transfer of Debentures in dematerialized form would be in accordance with the rules/procedures as prescribed by the Depository. Transfer of these Debentures is permitted only between categories eligible for subscription as mentioned in the respective General Information Document/Key Information Document/ Disclosure Documents/ Prospectus/ Offer Letter.
4. The Depository Account of the investors with the Depository will be credited within 2 days (in case of private placement) from the Deemed Date of Allotment or within such timelines as prescribed under Applicable Law. The initial credit in the account will be akin to the letter of allotment. On the completion of all statutory formalities, such credit will be substituted with the number of Debentures allotted.
5. The Debentures held in the dematerialized form shall be taken as redeemed on payment of the redemption amount by the Company on maturity to the registered Beneficial Owner(s) whose name appears in the list of Beneficial Owner(s) on the Record Date. Such payment will be a legal discharge of the liability of the Company towards the Beneficial Owner(s). On such payments being made, the Company will inform the Depository and accordingly the account of the Debenture Holder(s) with the Depository will be adjusted.
6. A list of Beneficial Owner(s) containing all relevant particulars, as maintained by the Depository, shall be kept by the Company at its Registered Office or such other place in accordance with the Act and such list shall be updated on a weekly basis.
7. Transfer of Debentures in dematerialized form would be in accordance with the rules/procedures as prescribed by the Depository. Transfer of these Debentures is permitted only between categories eligible for subscription as mentioned in the respective General Information Document/Key Information Document/ Disclosure Documents/ Prospectus/ Offer Letter. All requests for transfer should be submitted to the Company/Registrar prior to the Record Date for payment of interest/principal. Nothing provided herein shall prejudice any power of the Company to register as Beneficial Owner(s)/Debenture Holder(s) any person to whom the right to any Debenture of the Company has been transmitted by operation of law.

60

 <p>BAJAJ Finance Limited as the Issuer</p>	 <p>Catalyst Trusteeship Limited as the Debenture Trustee</p>
--	---

8. The Company shall accept the requests received from the Debentures Holders for rematerializing the Debentures in accordance with the rules and procedures prescribed by Depositories Act, 1996. All costs arising from the request of re-materialisation shall be borne by the person requesting such re-materialization.
9. Upon re-materialization of the Debentures held by the Debenture Holders, the Company shall maintain a register of Debenture Holders containing all relevant particulars at its registered office or such other place in accordance with the provisions of the Act and shall accordingly comply with all such rules, regulations and provisions as are stipulated for physical form of debentures.

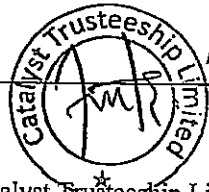
  BAJAJ Finance Limited as the Issuer	61	  Catalyst Trusteeship Limited as the Debenture Trustee
--	----	--

THE THIRD SCHEDULE ABOVE REFERRED TO

**PROVISIONS FOR THE MEETINGS
OF THE DEBENTURE HOLDER(S)/BENEFICIAL OWNER(S)**

The following provisions shall apply to the meetings of the Debenture Holder(s)/the Beneficial Owner(s):-

1. The Trustee or the Company may, at any time, and the Trustee shall call or cause to be called by the Company, at the request in writing of the holder(s)/owner(s) of Debentures representing not less than one-tenth in value of the nominal amount of the Debentures for the time being outstanding or the happening of any event, which constitutes a breach or default or breach of covenants (as specified in the General Information Document/Key Information Document/ Disclosure Documents/ Prospectus/ Offer Letter and/or this Deed) or which in the opinion of the Debenture Trustee affects the interest of the Debenture Holders, convene a meeting of the holder(s)/owner(s) of the Debentures. Any such meeting shall be held at such place in the city where the registered office of the Company is situated or at such other place as the Trustee shall determine.
2. The meetings of the holder(s)/owner(s) of Debentures can also be conducted by video conferencing / audio visual mechanism. The Debenture Trustee may seek the consent of Debenture holders through e-voting, wherever applicable.
3. (i) A meeting of the Debenture Holder(s)/the Beneficial Owner(s) may be called by giving not less than 15 (fifteen) days' notice in writing.
(ii) A meeting may be called after giving shorter notice than that specified in sub-clause (i), if consent is accorded thereto by Majority Debenture Holder.
4. (i) Every notice of a meeting shall specify the place, day and hour of the meeting and shall contain a statement of the business to be transacted thereat.
(ii) Notice of every meeting shall be given to:-
 - (a) the Debenture Holder(s)/the Beneficial Owner(s) in the manner provided in the Trust Deed;
 - (b) the persons entitled to a Debenture in consequence of death or insolvency of a Debenture Holder(s)/the Beneficial Owner(s), by sending it through post in a prepaid letter addressed to them by name or by the title of the representatives of the deceased, or assignees of the insolvent or by any like description at the address, if any, in India supplied for the purpose by the persons claiming to be so entitled or until such an address has been so supplied, by giving the notice in any manner in which might have been given if the death or insolvency had not occurred; and
 - (c) the Auditor or Auditors for the time being of the Company in the manner authorised by Section 20 of the Act in the case of any members of the Company;

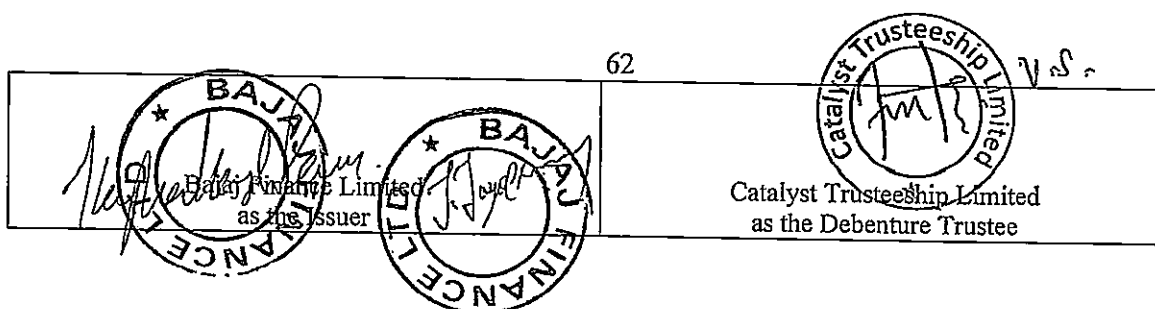

Provided that where the notice of a meeting is given by advertising the same in a newspaper circulating in the neighbourhood of the registered office of the Company, the statement of material facts referred to in Section 102 of the Act, need not be annexed to the notice as required by that Section but it shall be mentioned in the advertisement that the statement has been forwarded to the Debenture Holder(s)/the Beneficial Owner(s).



5. The accidental omission to give notice to, or the non-receipt of notice by any Debenture Holder(s)/the Beneficial Owner(s) or other person to whom it should be given shall not invalidate the proceedings at the meeting.
6. (i) There shall be annexed to the notice of the meeting a statement setting out all material facts concerning each such item of business, including in particular the nature of the concern or interest, if any, therein of every director, the manager, key managerial person if any, of the Company:

Provided that where any item of business as aforesaid to be transacted at a meeting of the Debenture Holder(s)/the Beneficial Owner(s) relates to, or affects, any other company the extent of shareholding interest in that company of every director, and the manager, key managerial person if any, of the first mentioned company shall also be set out in the statement if the extent of such shareholding interest is not less than two per cent of the paid-up share capital of that other company.

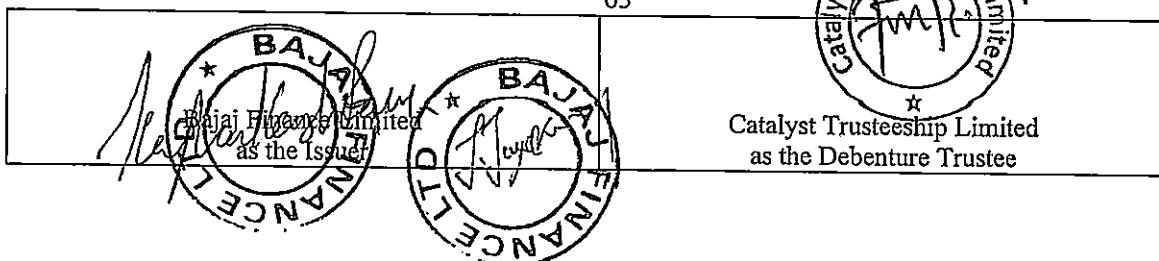
- (ii) Where any item of business consists of approval to any document by the meeting, the document shall be annexed to the notice and, the time and place where the document can be inspected shall be specified in the statement aforesaid.
7. Two Debenture Holder(s)/Beneficial Owner(s), personally present shall be the quorum for the meeting of the Debenture Holder(s)/Beneficial Owner(s) and provisions of following sub-clause shall apply with respect thereto. If there is a single Debenture Holder(s)/the Beneficial Owner(s) it shall constitute a valid quorum. If, within half an hour from the time appointed for holding a meeting of the Debenture Holder(s)/the Beneficial Owner(s), a quorum is not present, the meeting, if called upon the requisition of the Debenture Holder(s)/the Beneficial Owner(s) shall stand dissolved but in any other case the meeting shall stand adjourned to the same day in the next week, at the same time and place, or to such other day and at such other time and place as the Trustee may determine and if at the adjourned meeting also a quorum is not present within half an hour from the time appointed for the holding of the meeting, the Debenture Holder(s)/Beneficial Owner(s) present shall be a quorum.
 8. (i) The nominee of the Trustee shall be the Chairman of the meeting and in his absence the Debenture Holder(s)/ the Beneficial Owner(s) personally present at the meeting shall elect one of themselves to be the Chairman thereof on a show of hands.
(ii) If a poll is demanded on the election of the Chairman, it shall be taken forthwith in accordance with the provisions of the Act, the Chairman elected on a show of hands exercising all the powers of the Chairman under the said provisions.
(iii) If some other person is elected Chairman as a result of the poll, he shall be Chairman for the rest of the meeting.

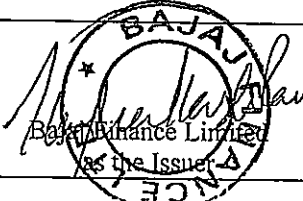

9. The Trustee and the Directors of the Company and their respective Solicitors/Advocates may attend any meeting but shall not be entitled as such to vote thereat.
10. At any meeting a resolution put to the vote of the meeting shall be decided on a show of hands unless a poll is demanded in the manner hereinafter mentioned, and unless a poll is so demanded, a declaration by the Chairman that on a show of hands the resolution has or has not been carried either unanimously or by a particular majority and an entry to that effect in the books containing the minutes of the proceedings of the meeting, shall be conclusive evidence of the fact, without proof of the number or proportion of the votes cast in favour of or against such resolution.
11. Before or on the declaration of the result on voting on any resolution on a show of hands a poll may be ordered to be taken by the Chairman of the meeting of his own motion and shall be ordered to be taken by him on a demand made in that behalf by the holder(s) of Debentures representing not less than one-tenth of the nominal amount of the Debentures for the time being outstanding present in person or by proxy.
12. (i) A poll demanded on a question of adjournment shall be taken forthwith
(ii) A poll demanded on any other question (not being a question relating to the election of a Chairman) shall be taken at such time not being later than forty-eight hours from the time when the demand was made as the Chairman may direct.
13. At every such meeting each Debenture Holder(s)/the Beneficial Owner(s) shall, on a show of hands, be entitled to one vote only, but on a poll he shall be entitled to one vote in respect of every Debenture of which he is a holder in respect of which he is entitled to vote.
14. (i) Any Debenture Holder(s)/the Beneficial Owner(s) entitled to attend and vote at the meeting shall be entitled to appoint another person (whether a Debenture Holder(s)/the Beneficial Owner(s) or not) as his proxy to attend and vote instead of himself.
(ii) In every notice calling the meeting there shall appear with reasonable prominence a statement that a Debenture-holder(s)/the Beneficial Owner(s) entitled to attend and vote is entitled to appoint one or more proxies to attend and vote instead of himself, and that a proxy need not be a Debenture Holder(s)/the Beneficial Owner(s).
(iii) The instrument appointing a proxy and the power of attorney (if any) under which it is signed or a notarially certified copy of the power of attorney shall be deposited at the Registered Office of the Company not less than forty-eight hours before the time for holding the meeting or adjourned meeting at which the person named in the instrument proposes to vote or in case of a poll, not less than twenty-four hours before the time appointed for the taking of the poll and in default, the instrument of proxy shall not be treated as valid.
(iv) The instrument appointing a proxy shall :-
(a) be in writing; and

 <p>BAJAJ Finance Limited as the Issuer</p>	 <p>BAJAJ Finance Limited</p>	 <p>Catalyst Trusteeship Limited as the Debenture Trustee</p>
--	--	---

- (b) be signed by the appointer or his attorney duly authorised in writing, or if the appointer is a body corporate, be under its seal or be signed by an officer or an attorney duly authorised by it.
- (v) The instrument appointing a proxy shall be in any of the form set out in Form MGT. 11 of the Companies (Management and Administration) Rules, 2014 and shall not be questioned on the ground that it fails to comply with any special requirements specified for such instruments by the Articles.
- (vi) Every Debenture Holder(s)/Beneficial Owner(s) entitled to vote at a meeting of the Debenture Holder(s)/Beneficial Owner(s) of the Company on any resolution to be moved thereat shall be entitled during the period beginning twenty four hours before the time fixed for the commencement of the meeting and ending with the conclusion of the meeting to inspect the proxies lodged, at any time during the business hours of the Company, provided not less than three days' notice in writing of the intention so to inspect is given to the company.
- (vii) A vote given in accordance with the terms of an instrument of proxy shall be valid notwithstanding the previous death or insanity of the principal or the revocation of the proxy or of the authority under which the proxy was executed or the transfer of the Debenture in respect of which the proxy is given provided that no intimation in writing of such death, insanity, revocation or transfer shall have been received by the Company at the Registered Office before the commencement of the meeting or adjourned meeting at which the proxy is used.
15. On a poll taken at any meeting of the Debenture Holder(s)/ Beneficial Owner(s), a Debenture Holder(s)/Beneficial Owner(s) entitled to more than one vote or his proxy or other person entitled to vote for him, as the case may be, need not, if he votes, use all his votes or cast in the same way all the votes he uses.
16. When a poll is to be taken, the Chairman shall appoint any person to act as the scrutinizer to scrutinise the votes given on the poll and to report thereon to him. The Chairman shall have power, at any time before the result of the poll is declared, to remove a scrutinesr from office and to fill vacancies in the office of scrutiniser arising from such removal or from any other cause.
17. (i) Subject to the provisions of the Act, the Chairman of the meeting shall have power to regulate the manner in which a poll shall be taken.
- (ii) The result of the poll shall be deemed to be the decision of the meeting on the resolution on which the poll was taken.
18. In the case of joint Debenture Holder(s)/Beneficial Owner(s), the vote of the first Debenture Holder who tenders a vote whether in person or by proxy shall be accepted to the exclusion of the other joint holder or holder(s)/owner(s). In case of absence of first Debenture Holder, the second or third Debenture Holder, as the case may be, shall be eligible to vote.
19. The Chairman of a meeting of the Debenture Holder(s)/Beneficial Owner(s) may, with the consent of the, adjourn the same from time to time and from place to place, but no business shall be transacted at any adjourned meeting other than the business left unfinished at the meeting from which the adjournment took place.

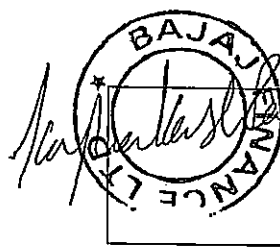
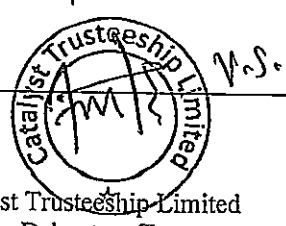
 <p>Bajaj Finance Limited as the Issuer</p>	<p>65</p>  <p>Catalyst Trusteeship Limited as the Debenture Trustee</p>
--	--

20. In the case of equality of votes, whether on a show of hands, or on a poll, the Chairman of the meeting at which the show of hands takes place or at which the poll is demanded, shall be entitled to a second or casting vote in addition to the vote to which he may be entitled to as a Debenture Holder(s)/Beneficial Owner(s).
21. The demand of a poll shall not prevent the continuance of a meeting for the transaction of any business other than the question on which a poll has been demanded.
22. The Chairman of any meeting shall be the sole judge of the validity of every vote tendered at such meeting. The Chairman present at the taking of a poll shall be the sole judge of the validity of every vote tendered at such poll.
23. The Debenture Holder(s)/Beneficial Owner(s) shall *inter alia* have the following powers exercisable in a meeting in the manner hereinafter specified:-
- (i) Power to sanction re-conveyance and release, substitution or exchange of all or any part of the Secured Assets from all or any part of the principal moneys and interest owing upon the Debentures.
 - (ii) Power to sanction any compromise or arrangement proposed to be made between the Company and the Debenture-holder(s)/Beneficial Owner(s).
 - (iii) Power to sanction any modification, alteration or, abrogation of any of the rights of the Debenture Holder(s)/ Beneficial Owner(s) against the, Company or against the Secured Assets or other properties whether such right shall arise under this Deed or the Debentures or otherwise.
 - (iv) Power to assent to any scheme for reconstruction or amalgamation of or by the Company whether by sale or transfer of assets under any power in the Company's Memorandum of Association or otherwise under the Act or provisions of any law.
 - (v) Power to assent to any modification of the provisions contained in this Deed and to authorise the Trustee to concur in the execution of any supplemental deed embodying any such modification.
 - (vi) Power to remove the existing Trustee and to appoint new debenture trustee in respect of the trust Securities.
 - (vii) Power to authorise the Trustee or any receiver appointed by them where they or he shall have entered into or taken possession of the Secured Assets or any part thereof to give up possession of such premises to the company either unconditionally or upon any condition.
 - (viii) Power to give any direction, sanction, request or approval which under any provision of this Deed is required to be given by a Special Resolution.
24. The powers set out in paragraph 23 hereof above, shall be exercisable by a Special Resolution passed at a meeting of the Debenture-holder(s)/Beneficial Owner(s) duly convened and held in accordance with provisions herein contained and carried by a majority consisting of not less than three-fourths of the persons voting thereat upon a

66

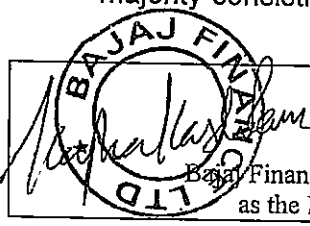
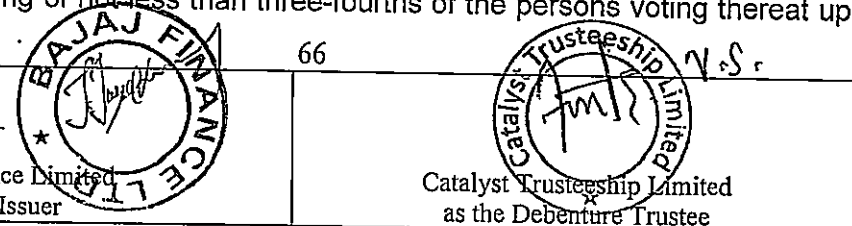
 <p>BAJAJ Finance Limited as the Issuer</p>	 <p>Catalyst Trusteeship Limited as the Debenture Trustee</p>
--	---

show of hands or if a poll is demanded by a majority representing not less than three-fourths in value of the votes cast on such poll.

25. A resolution, passed at a meeting of the Debenture-holder(s)/Beneficial Owner(s) duly convened and held in accordance with these presents shall be binding upon all the Debenture Holder(s)/ Beneficial Owner(s) whether present or not, at such meeting and each of the Debenture Holder(s)/Beneficial Owner(s) shall be bound to give effect thereto accordingly, and the passing of any such resolutions shall be conclusive evidence that the circumstances justify the passing thereof, the intentions being that it shall rest with the meeting to determine without appeal whether or not the circumstances justify the passing of such resolution.
26. Minutes of all resolutions and proceedings at every such meeting as aforesaid shall be made and duly entered into books from time to time provided for the purpose by the Trustee at the expenses of the Company and any such minutes as aforesaid, if purported to be signed by the Chairman of the meeting at which such Resolutions were passed or proceedings held or by the Chairman of the adjourned meeting shall be conclusive evidence of the matters therein contained and until the contrary is proved every such meeting in-respect of the proceedings of which minutes have been made shall be deemed to have been duly held and convened and all resolutions passed thereat or proceedings taken, to have been duly passed and taken.
27. Notwithstanding anything herein contained, it shall be competent to all the Debenture Holder(s)/Beneficial Owner(s) to exercise the rights, powers and authorities of the Debenture-holder(s)/Beneficial Owner(s) under this Deed by a letter or letters signed by or on behalf of the holder or holder(s)/owner(s) of atleast sixty percent in value of the Debentures outstanding without convening a meeting of the Debenture Holder(s)/Beneficial Owner(s) as if such letter or letters constituted a resolution or a special resolution, as the case may be passed at a meeting duly convened and held as aforesaid and shall have effect accordingly.
28. SEBI Master Circular for Debenture Trustees
- (a) If any meeting of the Debenture Holders is proposed to be conducted in respect of any matter prescribed in Chapter X: Breach of Covenants, Default and Remedies of the SEBI Master Circular for Debenture Trustees, the provisions of this paragraph 28 shall apply.
- (b) Any notice for a meeting in respect of the Chapter X: Breach of Covenants, Default and Remedies of SEBI Master Circular for Debenture Trustees shall contain the details prescribed in the SEBI Master Circular for Debenture Trustees, including without limitation, the negative consent for proceeding with the enforcement of security, positive consent for signing the inter-creditor agreement, the time period within which the consent needs to be provided, and the date of meeting to be convened.
- (c) The provisions of this Schedule (applicable to meetings of the Debenture Holders) shall apply in respect of any meeting that is conducted under this paragraph 28.
- (d) Any action of the Debenture Trustee in respect of the occurrence of an Event of Default and the application of the SEBI Master Circular for Debenture Trustees

67

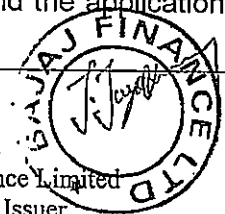
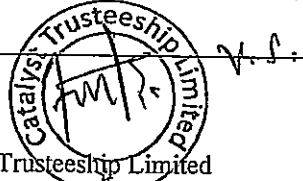
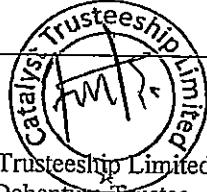
  Rajaj Finance Limited as the Issuer	  Catalyst Trusteeship Limited as the Debenture Trustee
--	--

shall be in accordance with the decision of the Debenture Holders taken at any meeting convened in accordance with this paragraph 28, subject to the exceptions (if any) set out in the SEBI Master Circular for Debenture Trustees.

- (e) For the purposes of a meeting convened in accordance with this paragraph 28, in accordance with the SEBI Master Circular for Debenture Trustees, all decisions shall require the consent of 75% (seventy five percent) of the Debenture Holders (by value) and 60% (sixty percent) of the Debenture Holders (by number).

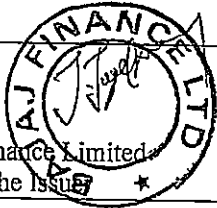
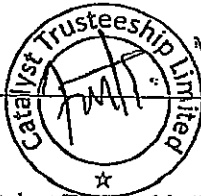
 <p>Bajaj Finance Limited as the Issuer</p>	 <p>Bajaj Finance Limited as the Issuer</p>	<p>68</p>  <p>Catalyst Trusteeship Limited as the Debenture Trustee</p>
--	--	---



THE FOURTH SCHEDULE ABOVE REFERRED TO

INFORMATION COVENANTS

1. The Company shall at the end of every calendar quarter within 45 (forty five) days of the respective quarter or within 7 (seven) days of the relevant Board meeting whichever is earlier, submit to the Debenture Trustee a report confirming /certificate confirming the following:
 - a) Updated list of names and addresses of all the Debenture Holder(s) and the number of Debentures held by the Debenture Holder (s)/Beneficial Owner(s);
 - b) Details of interest due but unpaid, if any, and reasons for the same;
 - c) Details of payment of interest made on the Debentures in the immediately preceding calendar quarter;
 - d) The number of grievances pending at the beginning of the quarter, the number and nature of grievances received from the Debenture Holder(s) during the quarter, resolved/disposed of by the Company in the quarter and those remaining unresolved by the Company and the reasons for the same; and
 - e) Statement that the Security is sufficient to discharge the claims of the Debenture Holder(s) as and when they become due.

The Company shall also submit a certificate from a statutory auditor for every quarter certifying the value of book debts/receivables and maintenance of the Security Coverage Ratio, as per the terms of Information Memorandum and this Deed including compliance with the financial covenants of the Information Memorandum on quarterly basis and all covenants on half yearly basis in respect of listed non-convertible debt securities in the manner as may be specified by SEBI from time to time.

2. The Company shall promptly submit to the Debenture Trustee any information, as required by the Debenture Trustee including but not limited to the following:
 - a) at the end of each financial year, a certificate from the statutory auditors of the Company with respect to the use of the proceeds raised through the issue of Debentures. Such certificate shall be provided at the end of each financial year until the funds are fully utilized;
 - b) by no later than 30 (thirty) days from the Deemed Date of Allotment or within such timelines as prescribed under Applicable Law, a certificate signed by an authorised officer of the Company confirming credit of dematerialized Debentures into the depository accounts of the Debenture Holder(s) within the timelines prescribed under the Applicable Laws;

  Bajaj Finance Limited as the Issuer	69	 Catalyst Trusteeship Limited as the Debenture Trustee
--	----	--

- c) a quarterly certificate regarding maintenance of 100% (hundred percent) or higher Asset Cover as per the terms of the relevant Pricing Supplements/Information Memorandum and/or this Deed, including compliance with all financial covenants, in respect of listed non-convertible debt securities, by the Statutory Auditor, along with the financial results, in the manner and format specified by the Board;
- d) upon there being any change in the credit rating assigned to the Debentures, as soon as reasonably practicable thereafter, a letter notifying the Trustee of such change in the credit rating of the Debentures, and further also inform the Debenture Trustee promptly in case there is any default in timely payment of interest or Redemption amount or both, or there is a failure to create charge on the Secured Assets, or there is a breach of any covenants, terms or conditions by the Company in relation to the Debentures under any Transaction Documents;
- e) a copy of all notices, resolutions and circulars relating to:
- (i) new issue of non-convertible debt securities at the same time as they are sent to shareholders/ holders of non-convertible debt securities;
 - (ii) the meetings of holders of non-convertible debt securities at the same time as they are sent to the holders of non-convertible debt securities or advertised in the media including those relating to proceedings of the meetings;
- f) at the time of requesting the Trustee for ceding *pari passu* charge over the Secured Assets in favour of the lenders from whom the Company avails borrowings, a certificate from an authorised officer of the Company, with necessary supporting documents if required, confirming the following:
- (i) that the security cover stipulated hereunder will continue to be maintained even after sharing of the charge over the Secured Assets; and
 - (ii) that no Event of Default has occurred or is continuing in terms of the Transaction Documents.
3. The Company shall promptly inform the Debenture Trustee of any disclosures made to the stock exchange in terms of Regulation 30 of the SEBI (Listing Obligations and Disclosure Requirements) Regulations, 2015 and which may have a bearing on the Debenture issue;
4. The Company shall promptly inform the stock exchange(s) and the Debenture Trustee all information having bearing on the performance/operation of the Company, any price sensitive information or any action that may affect the payment of interest or redemption of the Debentures in terms of Regulation 51(2) of the SEBI (Listing Obligations and Disclosure Requirements) Regulations, 2015. Further as per Regulation 52 (2) of the said regulations, the Company, shall without prejudice to the generality of sub-regulation (1), having listed non-convertible securities shall make disclosures as specified in Part B of Schedule III of the said regulations. Further, as per Regulation 51 (3) of the said regulations, the Company shall disclose on its website, all such events or information which have been disclosed to the Stock Exchange(s)

70

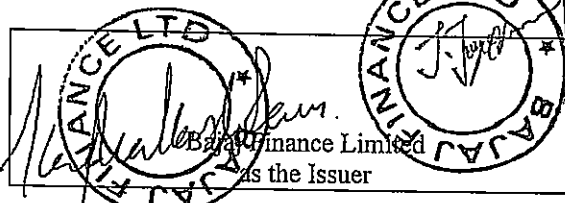
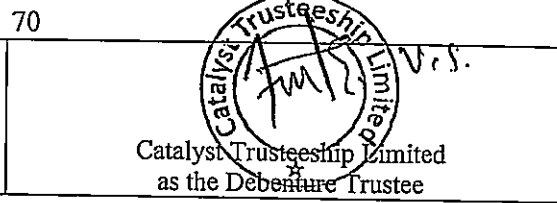
 <p>Bajaj Finance Limited as the Issuer</p>	 <p>Catalyst Trusteeship Limited as the Debenture Trustee</p>
--	---

pursuant to the said regulations and such disclosures shall be hosted on the website of the Company for a minimum period of 5 (five) years and thereafter as per the archival policy of the Company, as disclosed on its website. The Company shall also disclose to the Debenture Trustee at the same time as it has intimated to the Stock Exchange, all material events and/or information as disclosed under Regulation 51 of said regulations in so far as it relates to the interest, principal, issue and terms of non-convertible debt securities, rating, creation of charge on the assets, notices, resolutions and meetings of holders of non-convertible debt securities.

5. The Company shall promptly inform the Debenture Trustee the status of payment (whether in part or full) of Debentures within 1 (one) working day of the payment / Redemption. While intimating the Debenture Trustee, the Company shall also confirm whether they have informed the status of payment or otherwise to the stock exchange(s) and Depository.
6. Promptly within 1 (one) days of the interest or principal or both becoming due, the Company shall submit a certificate to the stock exchange(s) alongwith the Debenture Trustee, that it has made timely payment of interests or principal obligations or both in respect of the Debentures and also upload the information on its website.
7. If default in payment of Debentures is continuing, the Company shall inform the Debenture Trustee the updated status of payment latest by the 2nd working day of April of each financial year, alongwith the intimation on the updated status of payment to the stock exchange(s) and the Depository. Further, the Company shall also intimate the development, if any, that impacts the status of default of the Debentures (including restructuring, insolvency proceedings, repayment, etc.) to the stock exchange(s), Depository and Debenture Trustee within 1 (one) working day of such development. The aforementioned intimations shall be submitted until the Secured Obligations are fully discharged or satisfied. The Company shall provide an undertaking to the Stock Exchange(s) on annual basis that all documents and intimations required to be submitted to Debenture Trustees in terms of Trust Deed and SEBI (Issue and listing of Non Convertible Securities) Regulations, 2021 have been complied with and furnish a copy of such undertaking to the Debenture Trustee for records.
8. The Company shall promptly inform the Debenture Trustee the following details (if any):
 - a) corporate debt restructuring,
 - b) fraud/defaults by promoter or key managerial personnel or by Company or arrest of key managerial personnel or promoter; and / or
 - c) reference to National Company Law Tribunal or insolvency petitions (if any) filed by any creditor of the Company.
9. The Company shall submit to the stock exchange for dissemination, along with the quarterly /annual financial results, the following information alongwith the Debenture Trustee's letter of noting of the said information (to the extant applicable):
 - a) Debt-equity ratio;
 - b) Interest service coverage ratio;
 - c) capital redemption reserve/debenture redemption reserve;
 - d) Net worth;

71

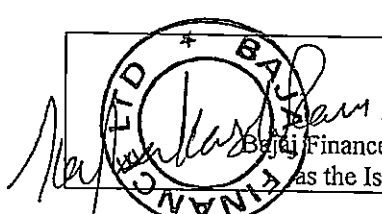
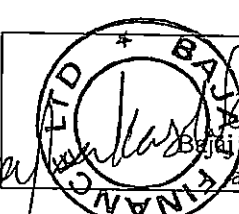
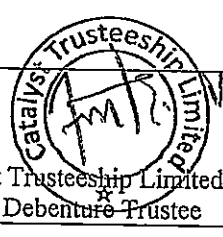
  Raj Finance Limited as the Issuer	 Catalyst Trusteeship Limited as the Debenture Trustee
--	---

- e) Net profit after tax;
- f) Earnings per share;
- g) current ratio;
- h) long term debt to working capital;
- i) bad debts to Account receivable ratio;
- j) current liability ratio
- k) total debts to total assets;
- l) debtors' turnover;
- m) inventory turnover;
- n) operating margin percent;
- o) net profit margin percent
- p) A statement indicating material deviations if any in utilisation of the proceeds of the Debentures.

10. The Company shall send to the Debenture Holders the following documents and information:-

- (a) Soft copies of the full annual reports to all the holders of non- convertible securities who have registered their email address(es) either with the listed entity or with any depository;
- (b) Hard copy of statement containing the salient features of all the documents, as specified in Section 136 of Companies Act, 2013 and rules made thereunder to those holders of non-convertible securities who have not so registered;
- (c) Hard copies of full annual reports to those holders of non-convertible securities, who request for the same;

The Company shall send the notice of all meetings of holders of non-convertible debt securities specifically stating that the provisions for appointment of proxy as mentioned in Section 105 of the Companies Act, 2013, shall be applicable for such meeting.

11. The Company shall send proxy forms to holders of non-convertible debt securities which shall be worded in such a manner that holders of these securities may vote either for or against each resolution. The Company shall submit to the and Stock Exchange and Debenture Trustee and publish on its website the following:

- (a) a copy of the annual report sent to the shareholders along with the notice of the annual general meeting, not later than the date of commencement of dispatch to its shareholders; and
- (b) in the event of any changes to the annual report, the revised copy along with the details and explanation for the changes, not later than 48 (forty eight) hours after the annual general meeting.

12. The Company shall submit a certificate to the Stock Exchange within 1 (one) working day of the interest or principal becoming due regarding status of payment in case of non-convertible securities.

13. Any further information which may be required to be submitted to the Stock Exchange pursuant to LODR Regulations, as amended from time to time.

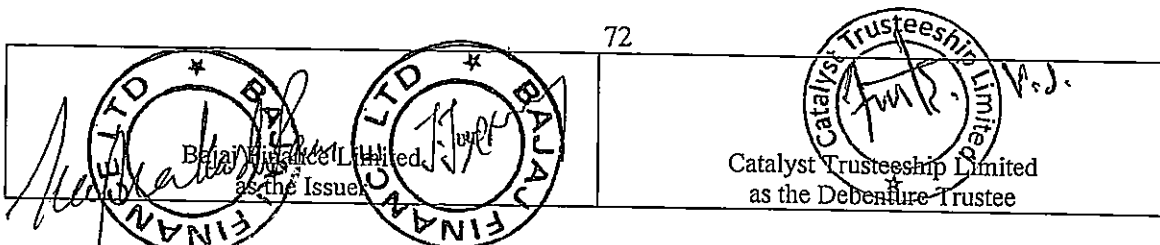

14. The Company shall notify the Trustee of any Event of Default (and the steps, if any, being taken to remedy it) promptly upon becoming aware of its occurrence.
15. The Company shall furnish to the Trustee details of all grievances received from the Debenture Holder(s)/ Beneficial Owner(s) and the steps taken by the Company to redress the same. At the request of any Debenture Holder(s)/ Beneficial Owner(s), the Trustee shall, by notice to the Company call upon the Company to take appropriate steps to redress such grievance and shall, if necessary, at the request of any Debenture Holder(s)/ Beneficial Owner(s) representing not less than one-tenth in value of the nominal amount of the Debentures for the time being outstanding, call a meeting of the Debenture Holder(s).
16. To provide relevant documents/ information as per SEBI guidelines and circulars as amended from time to time, as applicable, to enable the Debenture Trustee(s) to conduct continuous and periodic due diligence and monitoring of Security created, the Company shall submit the following reports/ certification within the timelines mentioned below:

Reports/Certificates	Timelines for submission requirements by Company to Debenture Trustee	Timeline for submission of reports/ certifications by Debenture Trustee to stock exchange
Security cover certificate	Quarterly basis within 60 days from end of each quarter or within such timelines as prescribed under Applicable Law	Quarterly basis within 75 days from end of each quarter except last quarter when submission is to be made within 90 days.
A statement of value of pledged securities		
A statement of value for Debt Service Reserve Account or any other form of security offered		
Net worth certificate of guarantor (secured by way of personal guarantee)	Half yearly basis within 60 days from end of each half-year or within such timelines as prescribed under Applicable Law	Half yearly basis within 75 days from end of each half-year.
Financials/value of guarantor prepared on basis of audited financial statement etc. of the guarantor(secured by way of corporate guarantee)	Annual basis within 60 days from end of each financial year or within such timelines as prescribed under Applicable Law.	Annual basis within 75 days from end of each financial year or within such timelines as prescribed under Applicable Law.
Valuation report and title search report for the immovable/movable assets, as applicable	once in three years within 60 days from the end of the financial year.	once in three years within 75 days from the end of the financial year.

73

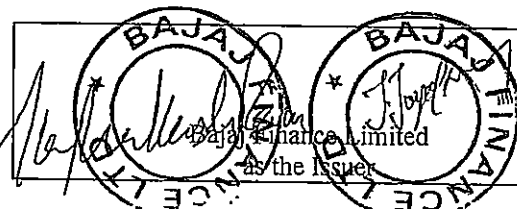
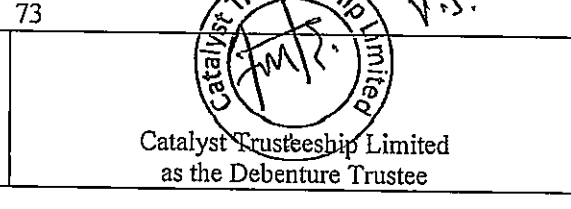
 <p>BAJAJ Finance Limited as the Issuer</p>	 <p>Catalyst Trusteeship Limited as the Debenture Trustee</p>
--	---

17. The Company shall promptly inform the Trustee of any major or significant change in composition of its Board, which may amount to change in control as defined in the SEBI (Substantial Acquisition of Shares and Takeovers) Regulations, 2011.
18. The Company shall inform the Debenture Trustee, of any amalgamation, demerger, merger or corporate restructuring or reconstruction scheme proposed by the Company.
19. The Company shall promptly supply certified copies to the Trustee of any authorisation required under any law or regulation to enable it to perform its obligations under the Transaction Documents (including, without limitation, in connection with any payment to be made hereunder) and to ensure the legality, validity, enforceability or admissibility in evidence in its jurisdiction of incorporation of the Transaction Documents.
20. The Company shall supply to the Debenture Trustee a copy of annual report at the same time as it is issued along with a copy of certificate from the Company's statutory auditor in respect of utilisation of funds, at the end of each year from the Deemed Date of Allotment, till the time such funds are fully utilized. In case the Debentures are issued for financing working capital or general corporate purposes or for capital raising purposes, copy of the auditor's certificate may be submitted at the end of each financial year till the funds have been fully utilised or the purpose for which these funds were intended has been achieved.
21. The Company shall supply to the Trustee (sufficient copies for all Debenture Holder(s) if the Trustee so requests) quarterly financial results within 45 (forty five) days of the end of each quarter, half yearly financial results within 45 (forty five) days from the end of the each half year, and the audited financial statements for a financial year (including statutory auditors report, directors' annual report, profit and loss accounts and a balance sheet) by no later than 60 (sixty) days from the end of the relevant financial year.
22. In case of initiation of forensic audit (by whatever name called) in respect of the Company, the Company shall provide following information and make requisite disclosures to the stock exchanges:
 - i. the fact of initiation of forensic audit along-with name of entity initiating the audit and reasons for the same, if available; and
 - ii. final forensic audit report (other than for forensic audit initiated by regulatory / enforcement agencies) on receipt by the Company along with comments of the management, if any.
23. The Company shall promptly provide or inform the Debenture Trustee the details of all orders, directions, notices, of any court/Tribunal affecting or likely to affect the Secured Assets.
24. The Company shall submit to the Debenture Trustee/stock exchange and the Debenture Holder(s) correct and adequate information (in the manner and format as requested by them or as required by Applicable Law) and within the time lines and procedures specified in the SEBI Regulations, Act, circulars, directives and/or any other Applicable Law.
25. The Company shall furnish the following to the Debenture Trustee:

74

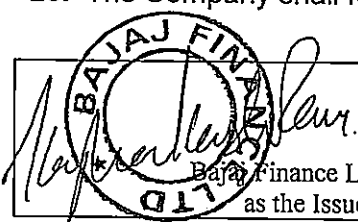
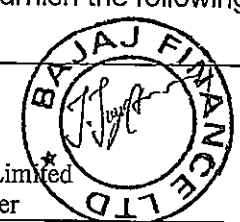
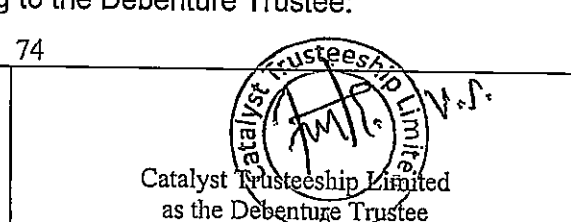

 <p>Bajaj Finance Limited as the Issuer</p>		 <p>Catalyst Trusteeship Limited as the Debenture Trustee</p>
--	---	---

- (a) its duly audited annual accounts, within 180 (One Hundred and Eighty) days from the close of its accounting year;
- (b) copy of the un-audited or audited financial results quarterly and year to date standalone financial results on a quarterly basis in the format as specified by the Board within 45 (forty- five) days from the end of the quarter, other than last quarter, to the recognised Stock Exchange;
- (c) a one-time certificate from the statutory auditor of the Company with respect to the use of the proceeds raised through the issue of Debentures as and when such proceeds have been completely deployed toward the proposed end-uses;
- (d) such information in relation to the Secured Assets that the Debenture Trustee may reasonably request (in a format which shall be provided by the Debenture Trustee from time to time) for the purpose of quarterly diligence by the Debenture Trustee to monitor the Security Coverage Ratio and shall also submit to the Debenture Trustee a certificate from authorised signatory of the Company on quarterly basis, certifying the value of the identified receivables as agreed in the Transaction Documents;
- (e) all information/ documents required to be submitted to the Debenture Trustee, to enable it to carry out the due diligence in terms of Operational Guidelines Circular, SEBI (Issue and Listing of Non-Convertible Securities), 2021, SEBI circular dated November 3, 2020 and bearing number SEBI/ HO/ MIRSD/ CRADT/ CIR/ P/ 2020/218; and necessary reports / certificates to the stock exchanges / SEBI and make the necessary disclosures on its website, in terms of the SEBI circular dated November 12, 2020 and bearing number SEBI/ HO/ MIRSD/ CRADT/ CIR/ P/ 2020/230.
- (f) The Company shall submit, a copy of the financial results submitted to Stock Exchange as per Clause 12 of this Fourth Schedule shall also be provided to Debenture Trustee on the same day the information is submitted to the Stock Exchange.

26. The Company shall:

- a) supply to the Trustee (with sufficient copies for all Debenture Holder(s) if the Trustee so requests) all documents despatched by it to its shareholders (or any class of them) or its creditors generally at the same time as they are despatched;
- b) promptly upon becoming aware, supply to the Trustee (and sufficient copies for all Debenture Holder(s) if the Trustee so requests), the details of any event which may have a Material Adverse Effect;
- c) promptly upon becoming aware, supply to the Trustee (and sufficient copies for all Debenture Holder(s) if the Trustee so requests), the details of the existence of any event or condition or claim which permits, or with the passage of time, will permit, the Company to abandon the business;
- d) promptly, supply to the Trustee (and sufficient copies for all Debenture

75

 BAJAJ Finance Limited as the Issuer	 BAJAJ Finance Limited as the Issuer	 Catalyst Trusteeship Limited as the Debenture Trustee
---	---	---

Holder(s) if the Trustee so requests), notice of any change in its authorised signatories (in connection with the Transaction Documents), signed by one of its directors or its company secretary, whose specimen signature has previously been provided to the Trustee, accompanied (where relevant) by a specimen signature of each new signatory;

- e) forthwith give, notice in writing to the Trustee of commencement of any proceedings directly affecting the Secured Assets.

27. The Company shall ensure that all the applicable regulations as per the SEBI (Listing Obligations and Disclosure Requirements), Regulations, 2015 as amended from time to time are duly complied with.

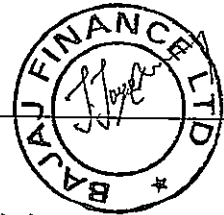
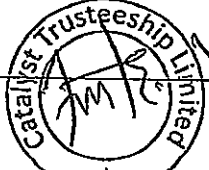
  Bajaj Finance Limited as the Issuer	76  Catalyst Trusteeship Limited as the Debenture Trustee
--	--

IN WITNESS WHEREOF the Company and the Debenture Trustee have caused this Deed to be executed the day and year first hereinabove written in the manner hereinafter appearing.

SIGNED and DELIVERED by the within-named BAJAJ FINANCE LIMITED by the hand of Mr./Ms.

K. PRAKASH RAM

J. JAYA KUMAR

its duly authorized official pursuant to the Resolution passed at the meeting of its Board of Directors held on _____.

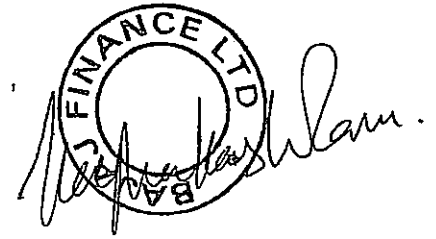

SIGNED AND DELIVERED by CATALYST TRUSTEESHIP LIMITED, the within named Debenture Trustee by the hand of

V.S. AMARNATH.

its Authorised Signatory.

For Catalyst Trusteeship Limited

V.S. Amarnath

Authorised Signatory

