

August 2, 2024

To,
Listing/Compliance Department
BSE LTD.
Phiroze Jeejeebhoy Towers,
Dalal Street,
Mumbai – 400 001.

BSE CODE : 524208

Dear Sir/Madam,

To,
Listing/Compliance Department
**National Stock Exchange of
India Limited**
“Exchange Plaza”, Plot No. C/1,
G Block Bandra-Kurla Complex,
Bandra (E), Mumbai – 400 051.
NSE Symbol : AARTIIND

Sub: Investor Presentation
Ref: Regulation 30(6) of the SEBI (LODR)
Regulations, 2015

Please find enclosed herewith presentation made to the Shareholders of the Company at the **41st Annual General Meeting** held today i.e. August 2, 2024.

Kindly take the same on record.

Thanking You,

Yours faithfully,
FOR AARTI INDUSTRIES LIMITED

RAJ SARRAF
COMPANY SECRETARY
ICSI M. NO. A15526
Encl. As above.



41st Annual General Meeting

2nd August, 2024

Resilient Today
Promising Tomorrow



AARTI INDUSTRIES LIMITED may, from time to time, make written and oral forward looking statements, in addition to statements contained in the company's filings with BSE Limited [BSE] and National Stock Exchange of India Limited [NSE], and our reports to shareholders. The company does not undertake to update any forward-looking statements that may be made from time to time by or on behalf of the AARTI INDUSTRIES LIMITED.

All information contained in this presentation has been prepared solely by AARTI INDUSTRIES LIMITED. AARTI INDUSTRIES LIMITED does not accept any liability whatsoever for any loss, howsoever, arising from any use or reliance on this presentation or its contents or otherwise arising in connection therewith.

01

**Company
Overview
and
Strengths**

02

**Key
Announce
ments and
Milestone**

03

**Financial
Snapshots**

04

**Growth
Opportunity
& Strategy**

05

**Awards
and
Corporate
Social
Responsibility**

About Aarti Industries Limited



Overview

- Established by first generation technocrats in **1984**
- Specialized in **Benzene & Toluene**-based derivatives
- Integrated** operations and high-cost optimization
- Key **value chains** include Nitro Chloro Benzenes, Di-Chlorobenzenes, Phenylenediamines, Nitro Toluene Value Chain and Sulphuric Acid & downstream
- Strong **R&D capabilities** with IPRs for customized products
- Strategically located:** In western India with proximity to ports



Geographical Revenue break-up (FY24)

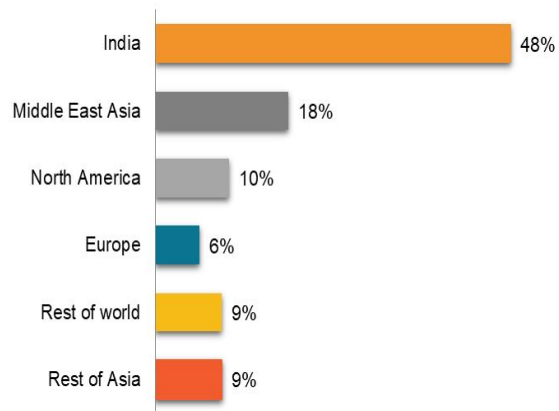

Key Strengths



Global Player in Benzene based Derivatives with Integrated Operations

Top 3

In Chlorination and Nitration globally

Top 2

In Hydrogenation globally



Well placed to benefit from Industry Tailwinds

Alternate to **China & Europe**

Fully Backward Integrated

Low-cost, sustainable manufacturing opportunities in sunrise sectors



Strong Focus on R&D and Process Innovation

40+

Products in R&D pipeline



Well Diversified Across Multiple Dimensions

100+

Multi-product

60+

Countries

400+

Global Customer

700+

Domestic Customer



Thrust on Sustainability

44%

Water recycled

8200 KL

Harvested through rainwater

18.75%

Women at board level

Key End-Use Industries Served

- Textiles and Fabrics
- Paints
- Medicines
- Air Fresheners
- Agrochemicals
- Polymers & Additives
- Oil Refineries

Well Diversified Across Various Regions

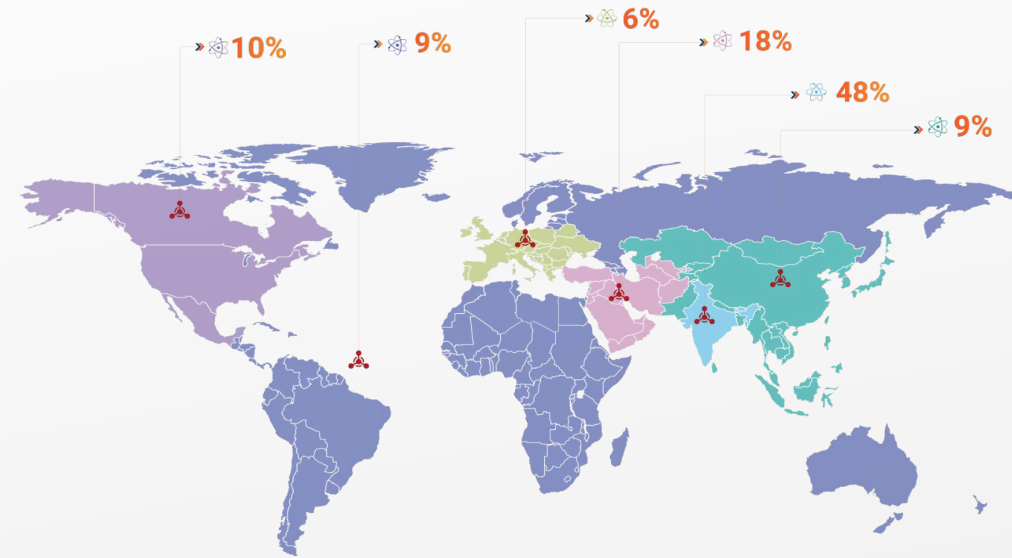

India
Middle East Aisa
North America
Europe
Rest of Asia
Rest of World

Key End-use profile

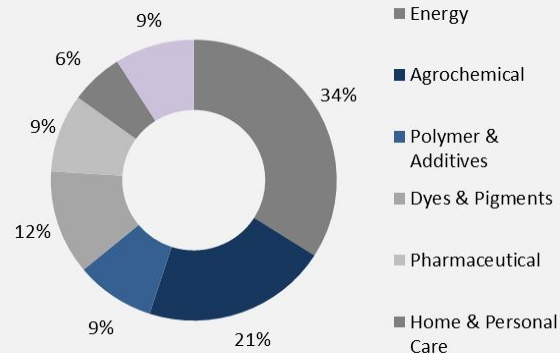

Key Customers

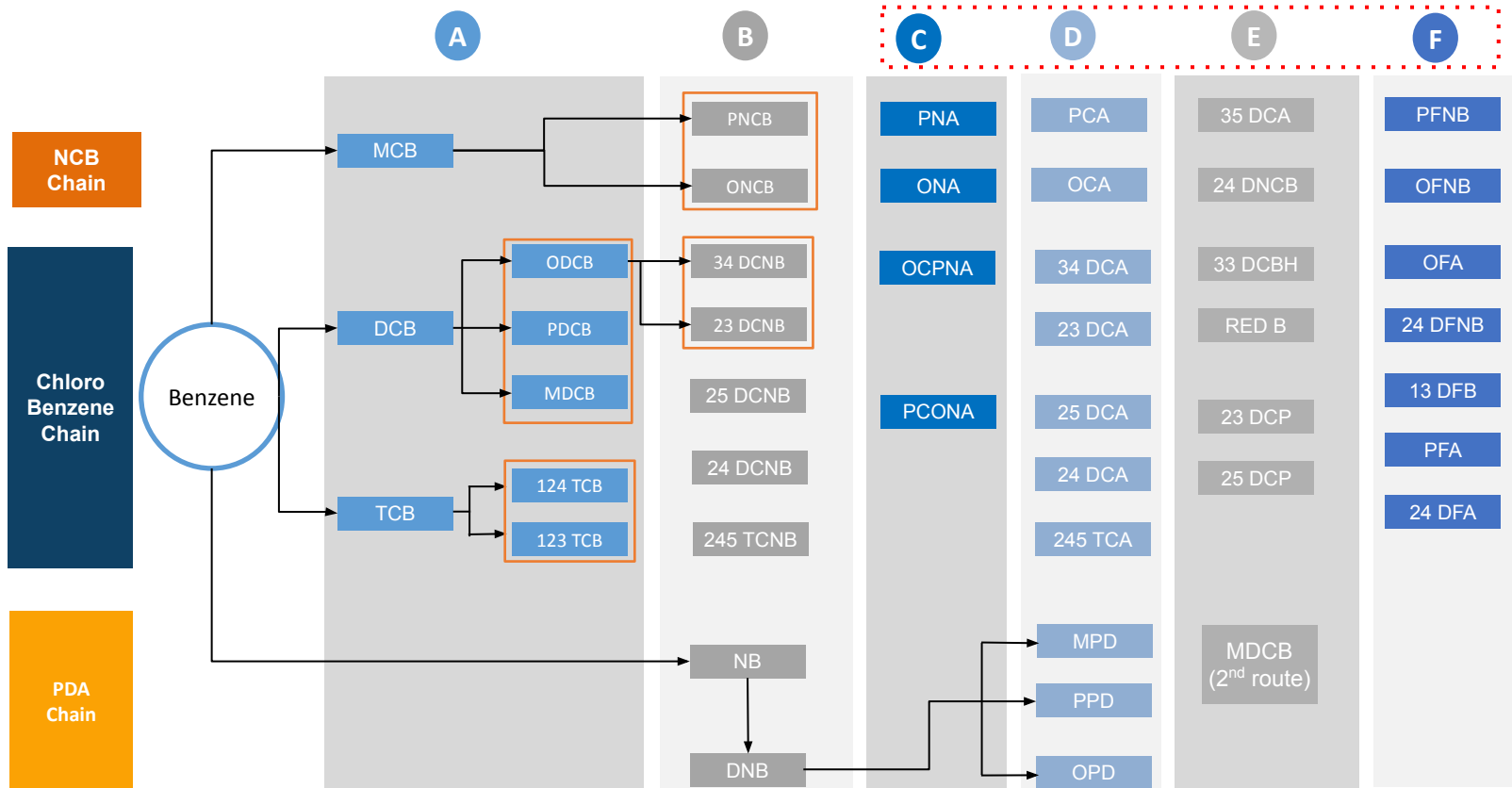

Process Classification

- A- Chlorination
- B-Nitration
- C-Ammonolysis
- D-Hydrogenation
- E-Specialty
- F-Halex

Strengths

- Integrated operations across product chain of Benzene and Toluene
- Co-products/Isomer balancing
- Optimizing product mix
- Ability to meet stringent specifications
- Supply chain not linked with China
- Focus on growth oriented products
- Diversified end uses

Global Ranking

NCB	Among Top 3 Globally	DCB	#1 Globally
-----	----------------------	-----	-------------

Domestic Ranking

Leading manufacturer for Nitro Fluoro Aromatics (via Halex chemistry) & PDA

Toluene Value Chain

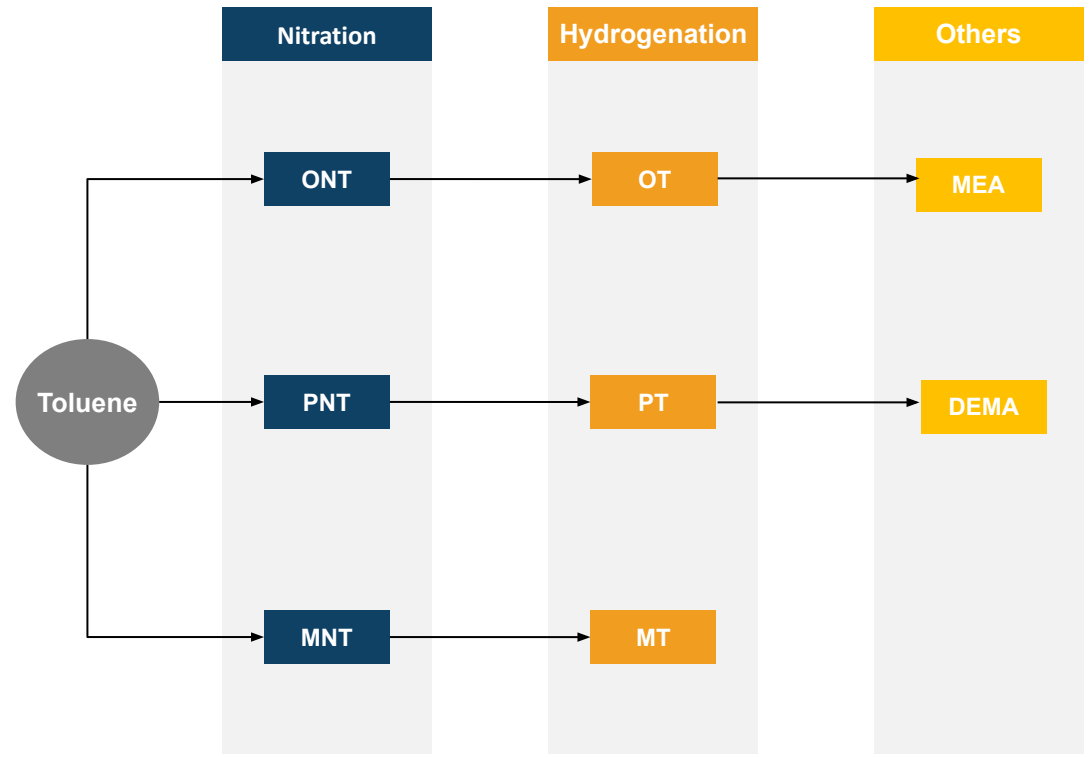

Sulphuric Acid Chain

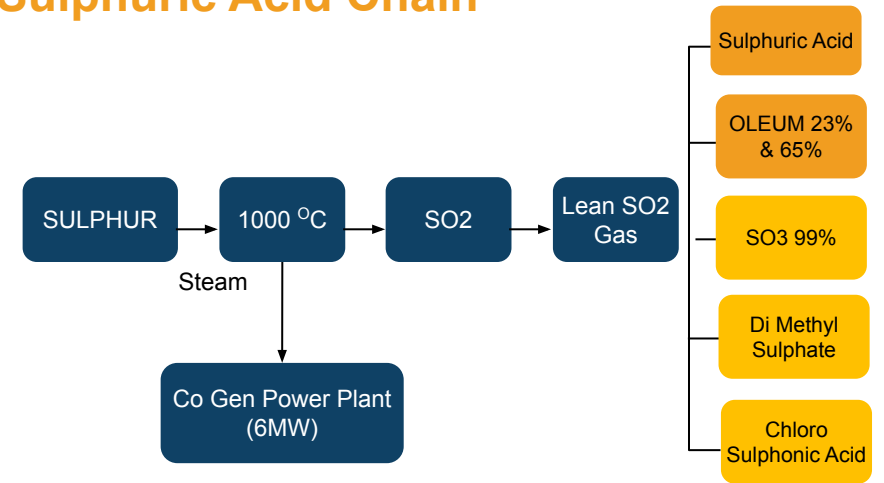

Other Speciality Chemical products

- Single Super Phosphate (SSP)
- Export Grade Calcium Chloride Granules (for Oil exploration & De-icing)
- Fuel Additives
- Phthalates

01

**Company
Overview
and
Strengths**

02

**Key
Announce
ments and
Milestone**

03

**Financial
Snapshots**

04

**Growth
Opportunity
& Strategy**

05

**Awards
and
Corporate
Social
Responsibility**

Key Announcements (Since last AGM)

December 2023

Entered into a long-term supply contract with a Global Agrochem major for a niche agrochemical intermediate with a revenue potential of over Rs. 3,000 crore

- To be executed over a period of 9 years commencing from current fiscal.
- Serves as a crucial input component for a widely used Herbicide; global market for this Herbicide remains large and growing steadily.
- Existing product for AIL and the product has already been supplied to the said customer for past few years.
- Current CAPEX well aligned to meet this order requirement.
- Anticipate an EBITDA margin of ~20% at current input prices.

January 2024

Entered into a 4-year supply contract worth over Rs. 6,000 crore with a multinational conglomerate for a niche specialty chemical

- To be executed from CY24 to CY27.
- Existing product for AIL and has been supplying this product to the said customer for the past few years with consistent annual increase in volumes.
- Volumes are expected to be doubled in CY24 vs that of CY23.
- Strong demand for this product based on newer applications which has been evolving over past 4 to 5 years.
- Current CAPEX well aligned to meet this order requirement.
- Expect ~15-17% EBITDA margin based on the current input prices.

May 2024

Joint Venture (JV) 50%-50% partnership for manufacturing and marketing of specialty chemicals that find application in multiple downstream industries

- Aarti Industries and UPL Ltd have announced the formation of 50%-50% JV for manufacturing and marketing of specialty chemicals
- The JV shall engage in supply of downstream derivatives of amines that have diverse applications in agrochemicals and paint industries
- The JV expected to commence commercial supplies by Q1FY27 with annual revenue potential of Rs. 400-500 crores 2-3 years post commercialization.
- The total investment towards the project is Rs.300 crores (Rs.150 crores by each JV Partner) over next two years.

Key Milestones - FY24

40+

Products in R&D pipeline

INR 1358 Cr.

CAPEX entailed

48 : 52

Domestic & Exports
revenue-mix

~85%

Contribution of
Value-Added Products

0.60x

Debt : Equity

On Projects:

- Commercialized of NCB Expansion project, thereby NCB Capacity scaled up from 75000 TPA to 107000 TPA.
- Completed and commercialised Phase 1 of the Acid Unit revamp.
- Phase 2 of the Acid Unit expansion and the debottlenecking and enhancement of Speciality Chemical units are underway.
- The greenfield initiatives at Zone IV in Jhagadia (Gujarat), spanning ~95 acres and encompassing the MPP, the pilot plant, and Chloro Toluene project, has been advancing as planned. These project is on track to be commercialised in a phased manner by FY26.

01

**Company
Overview
and
Strengths**

02

**Key
Announce
ments and
Milestone**

03

**Financial
Snapshots**

04

**Growth
Opportunity
& Strategy**

05

**Awards
and
Corporate
Social
Responsibility**

Key Performance Indicators (Consolidated)

Profit and Loss

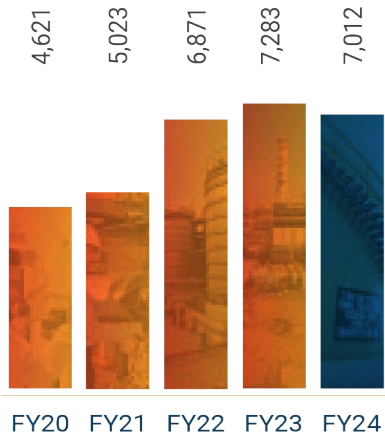

Gross income
(₹ in Cr)

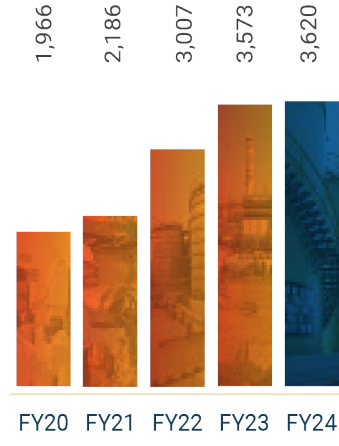

Revenue from exports
(₹ in Cr)

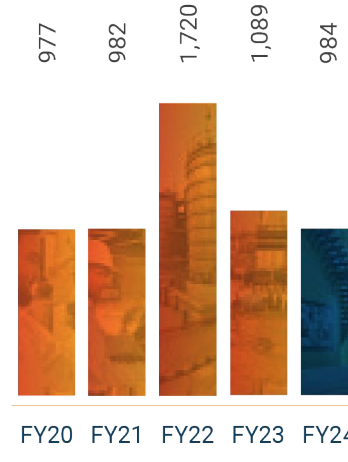

Operating EBITDA
(₹ in Cr)

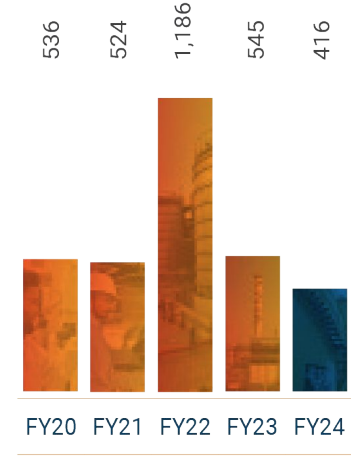

PAT
(₹ in Cr)

Balance Sheet Indicators

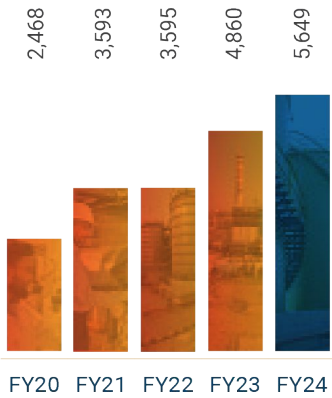

Net Fixed Assets
(₹ in Cr)

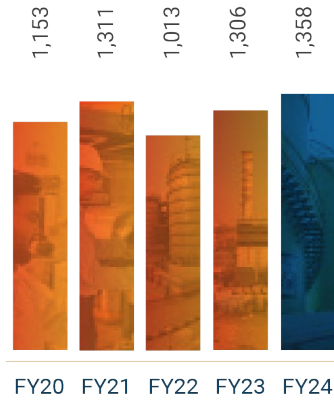

Capex
(₹ in Cr)

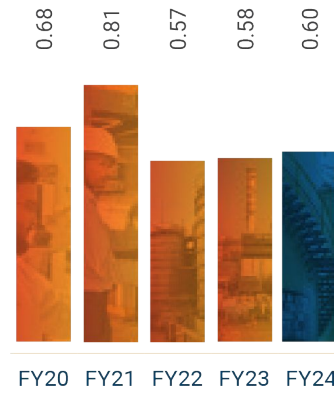

Debt To Equity Ratio

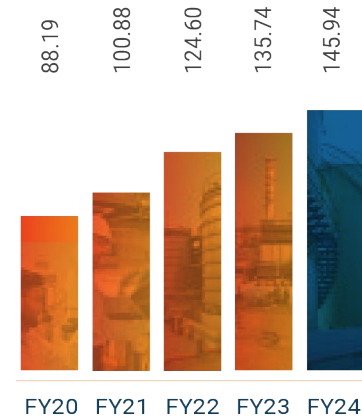

Book Value Per Share

Note:

1) FY22 financials include one-time contract cancellation income.

2) Erstwhile Pharma Segment of AIL got demerged into Aarti Pharmed Labs Ltd wef 1st July 2021. Hence financials upto 30th June 2021 are inclusive of Pharma business.

01

**Company
Overview
and
Strengths**

02

**Key
Announce
ments and
Milestone**

03

**Financial
Snapshots**

04

**Growth
Opportunity
& Strategy**

05

**Awards
and
Corporate
Social
Responsibility**

Future Growth Opportunities & Outlook

Growth Strategy

Partnership with Global Companies



- Collaborate with world's leading chemical companies
- Build on existing partnerships and build new ones
- Contract Manufacturing.

New Product Development



- Explore new value Chains
- Add new chemistry: e.g., Photochlorination, AHF Fluorination, etc.
- Expansion of existing Value chain

Bio and Sunrise sector



- Sustainable/ green products with focus on biochemistry, circularity, etc.
- Battery chemicals, Electronics chemicals, new age materials, high end polymers etc.

Outlook

FY25

- Recovery of Volumes across the sector, Ramp-up of capacities and higher operating leverages shall lead to EBITDA growth
- Commissioning of expanded capacities of NT and Ethylation
- Zone 4 to start gradually going onstream.

FY26 and beyond

- EBITDA growth driven by
 - Zone 4 ramping up.
 - New Strategic opportunities
 - Higher utilisation for existing capacities at Zone 1,2,3

01

**Company
Overview
and
Strengths**

02

**Key
Announce
ments and
Milestone**

03

**Financial
Snapshots**

04

**Growth
Opportunity
& Strategy**

05

**Awards
and
Corporate
Social
Responsibility**

CSR Interventions: Empowering Communities



Education & Skill
Development

₹ 6.8 crores



Healthcare

₹ 7.6 crores



Tribal & Rural
Development

₹ 1.0 crores



Environment &
Water Conservation

₹ 0.9 crores



Livelihood Opportunities
& Housing Aid

₹ 0.3 crores



Women
Empowerment

₹ 0.4 crores



Other CSR
Initiatives

₹ 0.1 crores



Total CSR Spend

INR 17.5 Crs.



FICCI Chemicals and Petrochemicals Awards 2023- Sustainability-Driving Circular Economy in Chemicals



FICCI Chemicals and Petrochemicals Awards 2023- Excellence in Exports



FICCI HR Innovation Award 2023



Chemexcil-GOLD AWARD"- Large Scale Manufacturer + Merchant for outstanding export performance



Chemexcil-Award of Excellency" Panel - I: Dyes & Dye Intermediates -(LSM + ME) for the outstanding export performance



Best Environment Friendly Company of the Year at FICCI Chemicals and Petrochemicals Award 2022



Thank You

Unlocking Opportunities

Building a Stronger Future

