



Jamna Auto Industries Ltd.

February 14, 2025

To,
BSE Limited
Exchange Plaza, Plot No. C/1, G- Block,
Phiroze Jeejeebhoy Towers, Dalal Street,
Mumbai- 400001 Maharashtra
BSE Code: 520051

To,
National Stock Exchange of India Limited
Exchange Plaza, Plot no. C/1, G Block,
Bandra-Kurla Complex, Bandra (E)
Mumbai - 400 051, Maharashtra
NSE Code: JAMNAAUTO

Subject: Investors Presentation on the financial results for the quarter and nine months ended December 31, 2024

Dear Sir/Madam,

Pursuant to the requirement of Regulation 30 and Regulation 46 of SEBI (Listing Obligations and Disclosure Requirements) Regulations, 2015, we are enclosing herewith the presentation by the Company pertaining to the financial results for quarter and nine months ended of December 31, 2024.

Kindly take the above information on records.

Thanking you,
Yours faithfully,
For Jamna Auto Industries Limited

Praveen Lakhera
Company Secretary & Head-Legal
Encl: As above



Jamna Auto Industries Limited

Investor Presentation

Q3 FY 24-25



This presentation and the accompanying slides (the “Presentation”), have been prepared by Jamna Auto Industries Limited (the “Company”), have been prepared solely for information purposes and do not constitute any offer, recommendation or invitation to purchase or subscribe for any securities, and shall not form the basis or be relied on in connection with any contract or binding commitment whatsoever. No offering of securities of the Company will be made except by means of a statutory offering document containing detailed information about the Company.

This Presentation has been prepared by the Company based on information and data which the Company considers reliable, but the Company makes no representation or warranty, express or implied, whatsoever, and no reliance shall be placed on, the truth, accuracy, completeness, fairness and reasonableness of the contents of this Presentation. This Presentation may not be all inclusive and may not contain all of the information that you may consider material. Any liability in respect of the contents of, or any omission from, this Presentation is expressly excluded.

Certain matters discussed in this Presentation may contain statements regarding the Company’s market opportunity and business prospects that are individually and collectively forward-looking statements. Such forward-looking statements are not guarantees of future performance and are subject to known and unknown risks, uncertainties and assumptions that are difficult to predict. These risks and uncertainties include, but are not limited to, the performance of the Indian economy and of the economies of various international markets, the performance of the industry in India and world-wide, competition, the company’s ability to successfully implement its strategy, the Company’s future levels of growth and expansion, technological implementation, changes and advancements, changes in revenue, income or cash flows, the Company’s market preferences and its exposure to market risks, as well as other risks. The Company’s actual results, levels of activity, performance or achievements could differ materially and adversely from results expressed in or implied by this Presentation. The Company assumes no obligation to update any forward-looking information contained in this Presentation. Any forward-looking statements and projections made by third parties included in this Presentation are not adopted by the Company and the Company is not responsible for such third party statements and projections.

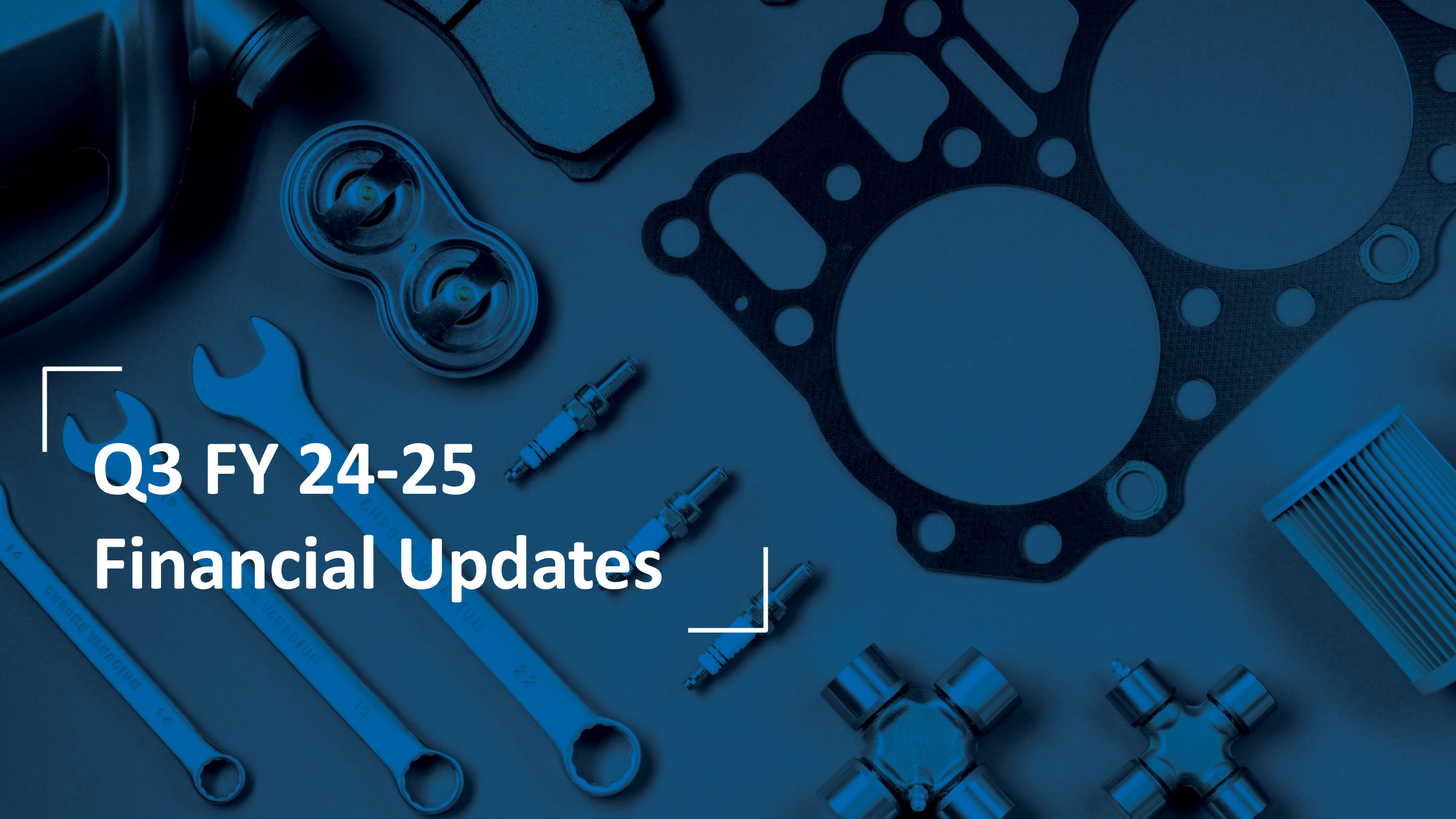

Q3 FY 24-25
Financial Updates

Financial Trends - QoQ



All figures are in INR crores

	Q3 FY 24-25	Q2 FY 24-25	Q3 FY 23-24
NET SALES	562	513	604
EBITDA	78/13.9%	67/13.1%	87/14.5%
PBT	63/11.2%	56/10.9%	74/12.2%
CASH ACCRUALS	58	51	67

Cash Accruals: PAT+ Depreciation

Financial Trends - YoY



All figures are in INR crores

	9 Months FY 24-25	9 Months FY 23-24	FY 23-24
NET SALES	1,632	1,787	2,427
EBITDA	221/13.6%	242/13.5%	331/13.7%
PBT	183/11.2%	205/11.5%	283/11.7%
CASH ACCRUALS	166	185	250

Cash Accruals: PAT+ Depreciation

Profit & Loss Statement



Consolidated QoQ

All figures are in INR crores

Particulars	Q3 FY 24-25	Q3 FY 23-24	YoY	Q2 FY 24-25	QoQ
Net Sales	562	604	-7%	513	10%
EBITDA	78	87	-11%	67	16%
PBT	63	74	-14%	56	13%
PAT	44	55	-20%	40	10%

Profit & Loss Statement



Consolidated YoY

All figures are in INR crores

Particulars	9 Months FY 24-25	9 Months FY 23-24	YoY	12 Months FY 23-24
Net Sales	1,632	1,787	-9%	2427
EBITDA	221	242	-8%	331
PBT	184	205	-11%	283
PAT	130	151	-14%	205

Revenue Mix



Product Mix

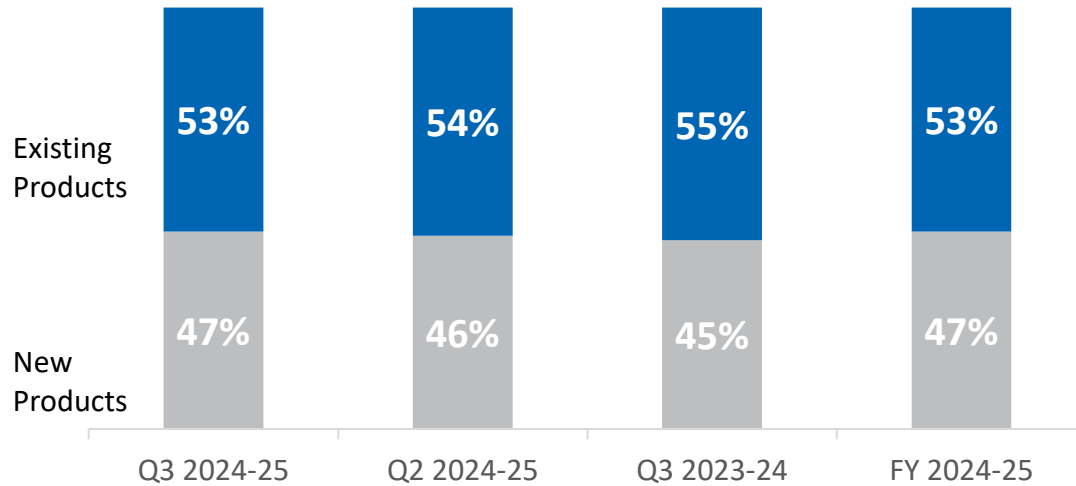

Lakshya Target: **50%** revenue from New Products by FY 2026-27

Market Mix

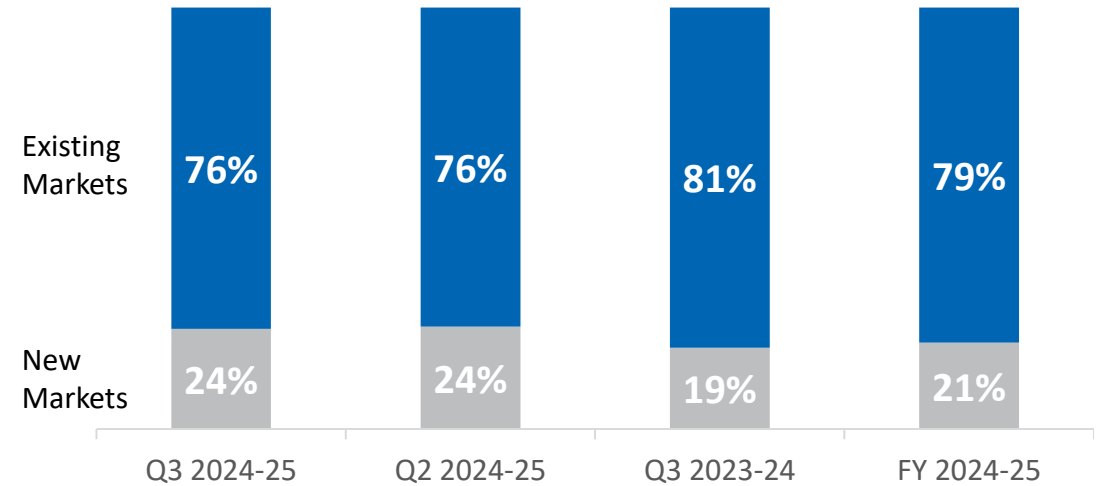

Lakshya Target: **50%** revenue from New Markets by FY 2026-27



Industry Highlights

Industry Highlights



All figures are in '000

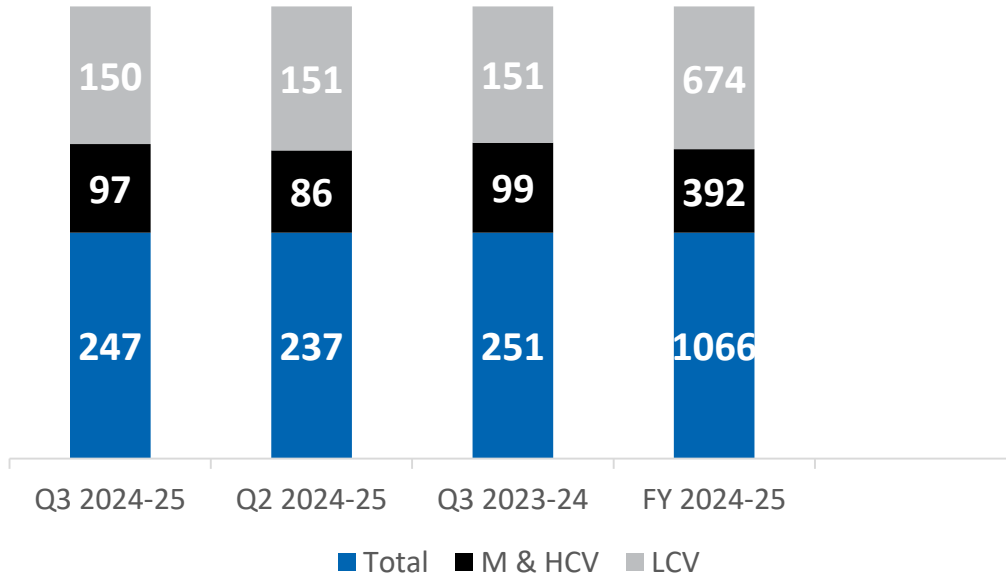

Data Source-SIAM

LCV production changes

- ↓ - Q3 FY25 vs Q2 FY25 - 1% (Decrease)
- ↓ - Q3 FY25 vs Q3 FY24 - 1% (Decrease)

M&HCV production changes

- ↑ - Q3 FY25 vs Q2 FY25 - 12% Increase
- ↓ - Q3 FY25 vs Q3 FY24 - 3% (Decrease)

For the Quarter

QoQ Change %	YoY Change %
- 1%	-1%
12%	-3%
4%	-1%

Company Update



Jai Automotive Components Limited, our Wholly Owned Subsidiary, have closed its manufacturing units at Pant Nagar, Uttarakhand and Dera Bassi, Punjab. These closures do not have any material impact on the consolidated financial results.

The decision aligns with group's strategic focus on core products, particularly the manufacturing of springs, Suspension, U-bolts, and other upcoming products which are in pipeline. This restructuring will enable us to enhance efficiency and better allocate resources toward our upcoming facilities





Company Overview

JAI at a Glance





 **Foundation**
JAI is a renowned suspension manufacturer for commercial vehicles.

 **World class Manufacturing Infrastructure**
8 Manufacturing units including 1 In-house R&D center



- More than 16,000 touch points
- JAI Shoppe in Sanjay Gandhi Transport Nagar, Delhi which is one of the largest trucking center in India.

 **Manufacturing**
~300+ OEM parts
~5,000+ AMI parts

 **Sound Financials**
CRISIL A1+/AA-

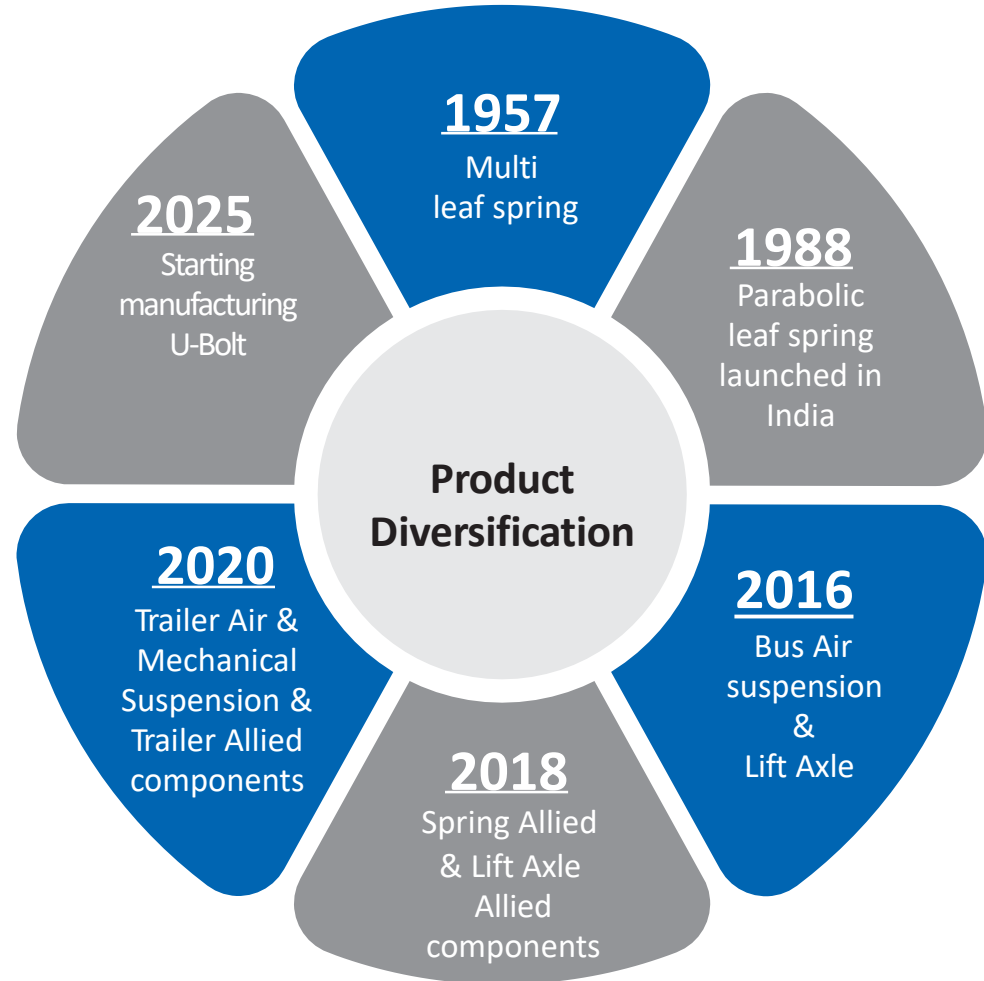

Jai's Plants : Strategically Located Across OEM Plants

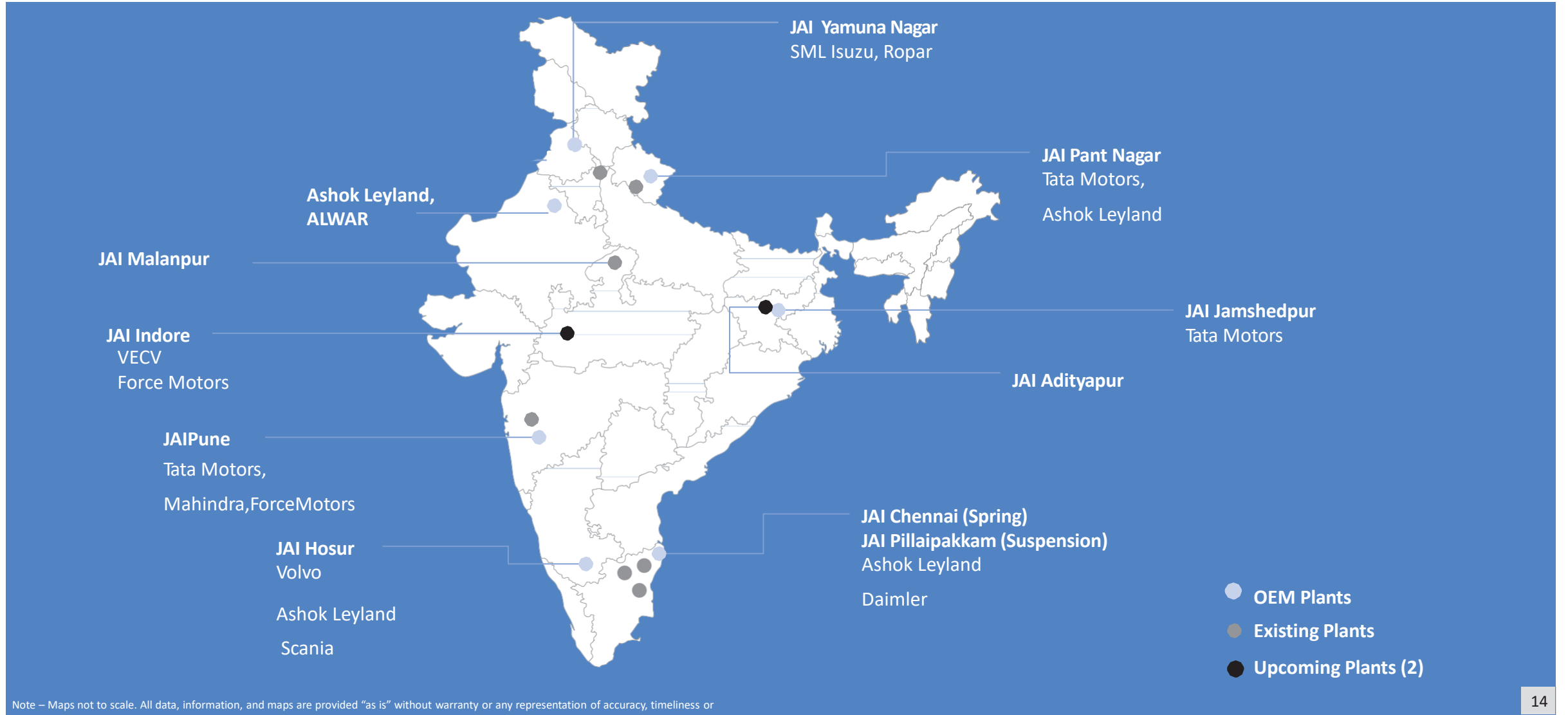

Strength and Key Focus Areas

Strength

- Manufacturing footprint with logistics benefit.
- Low BEP with Low Leveraged.
- Spare capacity to capture unprecedented demand from all Markets.
- Wide After Market Network
300+ Distributors,
11500+Retailers,
15000+ Mechanics.



Key Focus Areas

- New Markets (AMI, AME).
- New Products (Trailer, CPV in CV).

JAI's OEM Customers

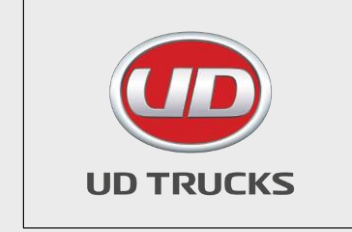
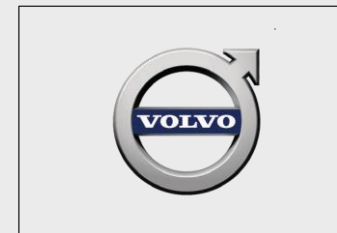

JAI's Product Portfolio

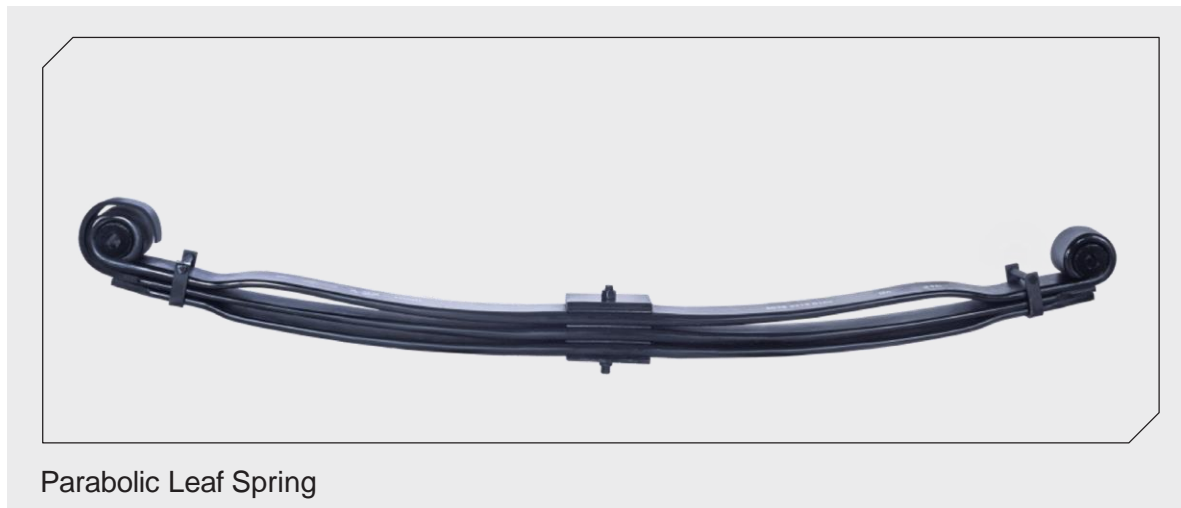

JAI's Product Portfolio

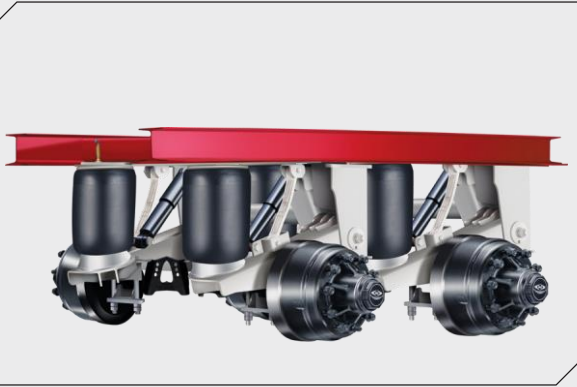

Bus Air Suspension

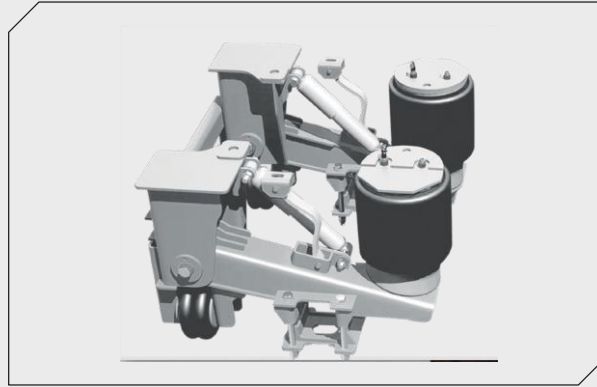

Trailer Air Suspension



Lift Axle

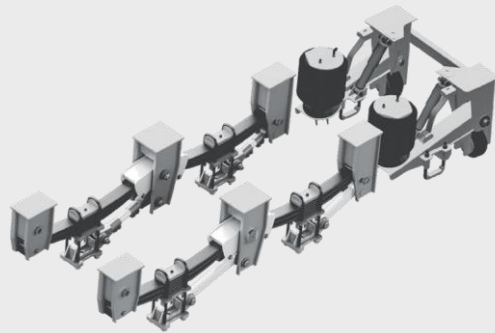

Trailer Mechanical and Air Suspension with Lift Axle



Trailer Mechanical Suspension

After Market India JAI's Product Portfolio



Lift Axle Allied Components

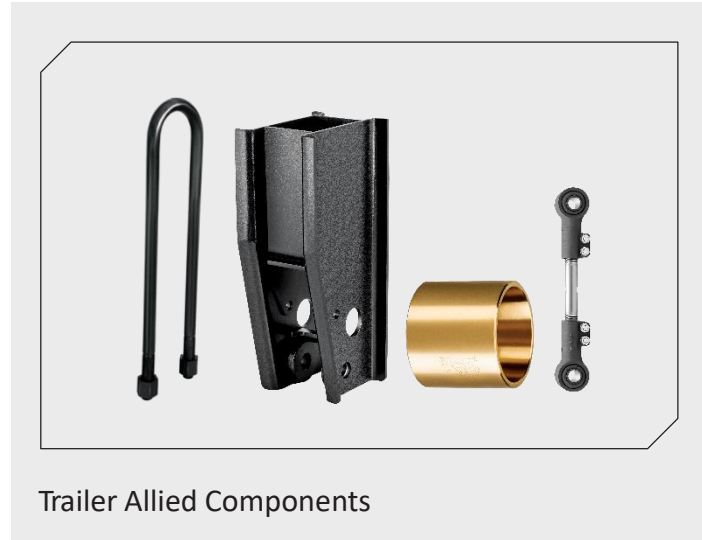

Trailer Allied Components

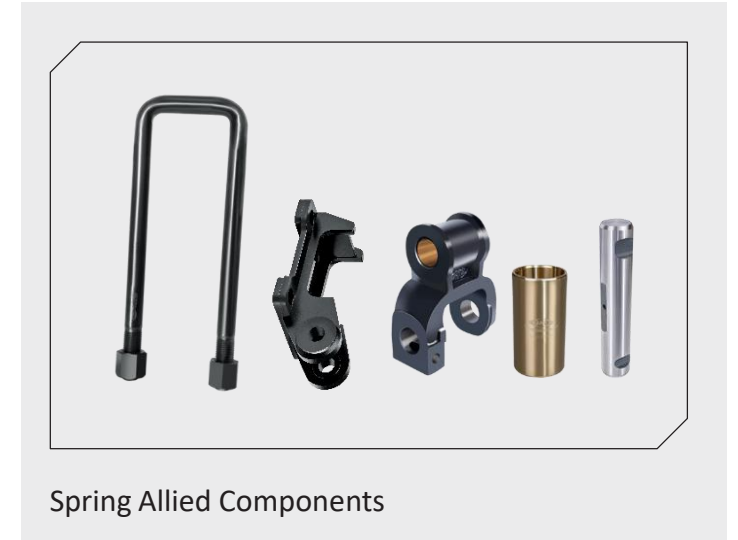

Spring Allied Components

After Market India JAI's Product Portfolio



Brake lining

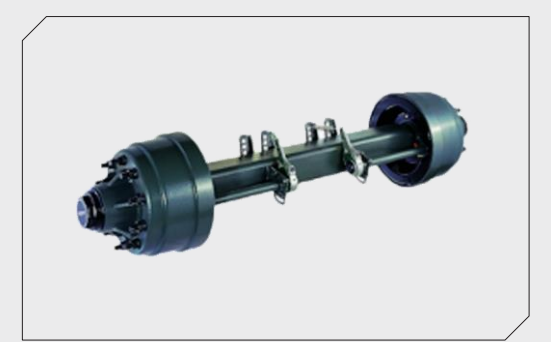

Trailer Axle



Water Pump



Clutch

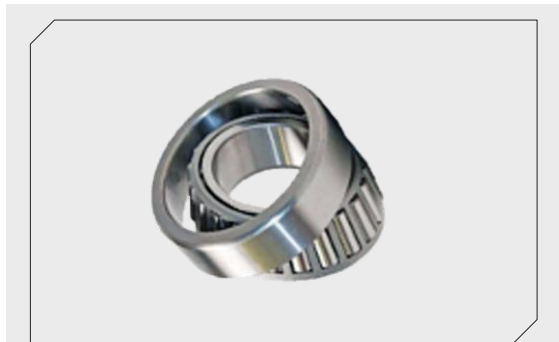

Bearing

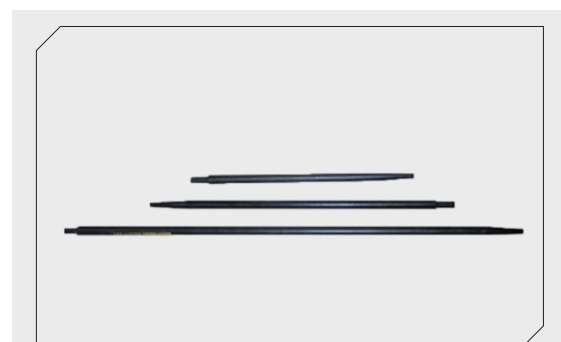

Jack Rod

Most of the products above are only traded

Jamna Auto Industries Limited ('JAI')

Shareholding Pattern as on 31st Dec 2024

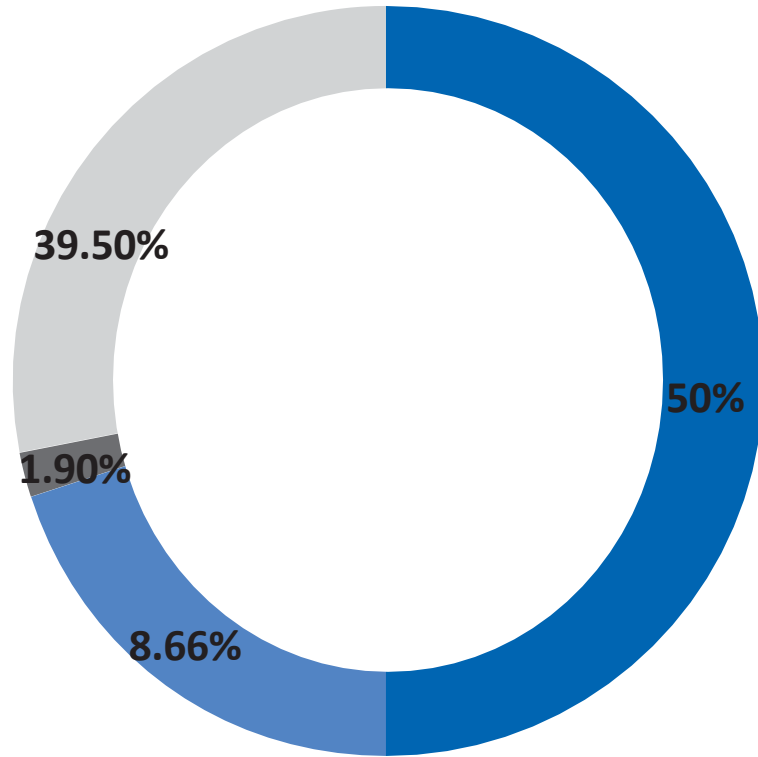

- Promoters
- Institutional investors

Categories	% Holding as on 31.12.2024	% Holding as on 31.3.2024
Promoters	50%	50%
Institutional Investors	8.66 %	14.81%
Bodies Corporate	1.9%	1.75%
Individual & Others	39.5%	33.44%
Total	100%	100%

Contributing to the Society



We are committed to contribute to the social and economic welfare of communities in which we operate. Playing an active role in sustaining positive change within society, we aim to create opportunities for the holistic development of people from all sections of society.



Planted saplings in green belt, Pant Nagar



Awarding scholarship to girl students in Akaal University, Bhatinda



Awarded winners in sponsored Half Marathon event in Gurgaon



Provided blankets and ration kits to homeless widows in Vrindavan



Contributing to the Society



Environment

- Planted 1310 saplings in YNR, JSR & Pant Nagar.
- Maintained 5500 meter green belt in Malanpur, YNR & Pant Nagar.
- Produced 15000 kg shivansh manure, 25000 kg vermin-compost in Delhi, YNR & Jamshedpur.
- Conducted a cleanliness drive in Yamuna Nagar by involving Govt. school students, community people & volunteers.
- Distributed 500 jute bags to factory workers and villagers in Yamuna Nagar & Pant Nagar.



Education

- Awarded annual scholarship to 470 meritorious and needy students to support their studies.
- Awarded 188 meritorious students in Govt. Schools by gifting laptop, smart phones & bicycles in YNR, JSR & Pillaipakkam.
- Provided study material & furniture to 18 Govt. schools in Yamuna Nagar & Chennai.
- Distributed quarterly dental kits (2200) to students in Govt. primary schools in YNR, JSR, PKM & Pant Nagar.
- Total 206 female completed stitching & tailoring course in YNR & Delhi.
- Total 81 youths & inmates completed basic and advance course in Delhi, JSR & Gurgaon



Sports

- Awarded annual sponsorship to 54 star sportspersons in Guru Nanak Khalsa College, YNR
- Awarded annual sponsorship to 05 athlete's in Abhinav Bindra Foundation for one year training programme
- Powered sponsored Karma Lakelands Half Marathon-2024 in Gurgaon.
- Sponsored monthly diet to 11 sportspersons in YNR .
- Provided sports equipment to 20 Govt. schools in YNR, JSR & Pant Nagar.
- Sponsored to Kabaddi team in state level tournament in Tamilnadu.
- Constructed toilets for boys and girls trainees in NCC Training Centre, YNR
- Our sponsored shotgun shooter Mr. Abahy Singh won bronze in individual and gold in team in World University Championship, New Delhi.

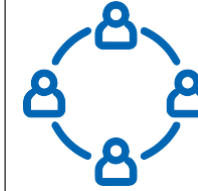

Community Reach

- Organized 06 multispecialty health camps for community, 750 patients were screened and treated in YNR, JSR, Hosur.
- Operated cataract for 39 patients in Yamuna Nagar.
- Distributed 3200 blankets to homeless people, rain basera, slums & streets in Vrindavan, GGN, Pant Nagar & JSR.
- Provided equipment to 65 needy PwD's in Yamuna Nagar on the occasion of World Disability Day.
- 500 ration kits distributed to homeless widows in Vrindavan, UP.
- 60 nutrition kits distributed to needy anemic pregnant women in Chennai.
- Monthly nutrition kits distributed to needy 50 TB patients in JSR.
- Provided 04 water heaters for Child Care Home, financial support to 04 BPL families for their daughters marriage.
- Distributed monthly pension to 124 sr. citizens, widow and PwD's in YNR.
- Installed 85 street lights in adopted villages and Govt. schools in Yamuna Nagar.





Thank You
