

July 26, 2021

To,
National Stock Exchange of India Limited
Symbol – SYMPHONY

To,
BSE Limited
Security Code - 517385

Sub.: Investor Presentation – Updates

Dear Sir,

This is in reference to the above-mentioned subject line; we are enclosing herewith updated Investor Presentation. The same is also available on the website of the Company.

Kindly consider this as due compliance of relevant provisions of SEBI (Listing Obligations and Disclosure Requirements) Regulations, 2015.

Kindly take this on your record and oblige.
Thanking you,

Yours Truly,
For Symphony Limited

Mayur Barvadiya
Company Secretary

Encl.: as above.

Email: companysecretary@symphonylimited.com

A large, white silhouette of a bird in flight, positioned on the left side of the slide. The bird's wings are spread, and its tail is visible. The silhouette is set against a green background that transitions from a lighter shade on the left to a darker shade on the right.

Earnings
PRESENTATION

Q1FY22

For better viewing experience kindly watch on Desktop/Laptop

Disclaimer

Safe Harbour Statement

This presentation contains forward-looking statements which may be identified by their use of words like “plans,” “expects,” “will,” “anticipates,” “believes,” “intends,” “projects,” “estimates” or other words of similar meaning. All statements that address expectations or projections about the future, including, but not limited to, statements about the strategy for growth, product development, market position, expenditures, and financial results, are forward-looking statements. Forward-looking statements are based on certain assumptions and expectations of future events. The companies referred to in this presentation cannot guarantee that these assumptions and expectations are accurate or will be realized. The actual results, performance or achievements, could thus differ materially from those projected in any such forward-looking statements. These companies assume no responsibility to publicly amend, modify or revise any forward looking statements, on the basis of any subsequent developments, information or events, or otherwise.

Portfolio of Global Brands



Master Cool[®]
by Symphony

Arctic Circle[®]
by Symphony

ki

 **BONAIRE**[®]
The leaders in heating and cooling

 **CELAIR**

 **AIRAZONA**



Management Comments

Management View on Performance & Outlook

Actual Performance:

- FY21 and Q1FY22 performance were impacted on account of the Covid-19.
- A second wave of Covid-19 struck during 2021 summer; coupled with the extensive lockdown in the summer of 2020 – both, the peak season for air cooler customer sales.
- Until middle of April-21 very robust demand and sentiments. Complete focus on maximising production
- Most of the advertisement and sales expenses were incurred in April-21 considering high demand. Hence, impacted EBITDA margins.
- However, our exports and overseas subsidiaries were not much impacted.

Management View on Performance & Outlook

Outlook :

- Management is reasonably confident to achieve much better performance in FY22 vis-à-vis FY21 on account of:
 - ✓ Variety of initiatives already undertaken by the management
 - ✓ Estimated Sharp increase in exports
 - ✓ In Jun-21 gross margin is in line with FY21 despite huge increase in input & freight costs. The Management expects gross margin on domestic sales for FY22 will be back to normal margin of around 50%
 - ✓ Accelerated turnaround of Climate Technologies in Australia in FY22 despite until Dec-20 it has been below expectation



New Launches – Symphony India

New Launch

DiET3^D



Pop-up Touchscreen

Easy-to-use touchscreen control panel that pops up



3D Cooling

3-side cooling pads for superior cooling experience

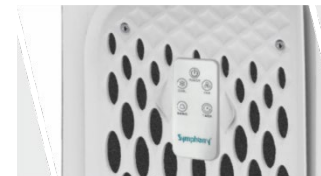

Magnetic remote

Sticks on the cooler body

New Launch

New SUMO

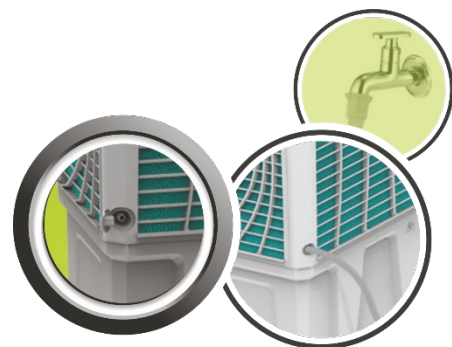

'Easy-Fill' for hassle-free water filling



i-Pure console with multistage air purification filters



Specially designed +Air fan for more air



High efficiency honeycomb pads for superior cooling



New Launch

Hi Flo



Powerful air throw



Cool flow dispenser



High efficiency honeycomb
for superior cooling



i-Pure technology



Large 27L water-tank cap

New Launch

DUJET
Series

Symphony[®]

Refreshing Lives

Symphony[®]

Refreshing Lives



Cooling Fan
from the house of Symphony

Available on **Flipkart** 

New Launch

Symphony®

Refreshing Lives

DUET[®] Cooling Fan Series

Currently available exclusively on e-commerce platforms, Symphony Duet is a personal cooling fan that boasts dual functionality of a fan and a cooler. It is available in two variants: Pedestal & Table.

- ✓ Detachable pedestal for dual usage - on the table or floor-standing
- ✓ Touchscreen control
- ✓ Surround cooling with swing option
- ✓ Honeycomb cooling pads
- ✓ Easy to carry



New Campaign

For Household air coolers

*Mann Thanda
Tann Taaza Rahe*

Objective:

To put across a view that cool air can bring new perspectives in people's lives.

BL Business Line

Summer cool

Air cooler brand Symphony, too, has got into the summer spirit, launching its 'Mann Thanda Tann Taaza Rahe' campaign.

21-Mar-2021

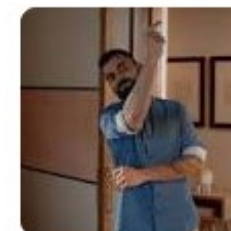



Symphony



Industrial and Commercial air coolers

Industrial and commercial air coolers (Latest launches)



Universal air cooler – top and bottom discharge in the same cooler

Four-side high efficiency honeycomb pads

Powerful air throw

Robust weather-resistant body

Launched a range of accessories

For easy and quick installation of industrial air coolers



Mouthpiece

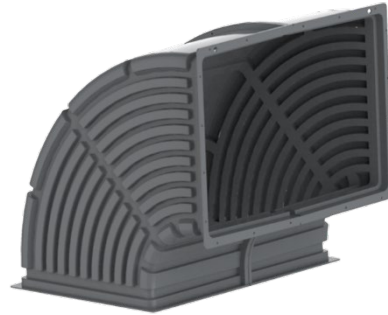

Elbow



Modular duct



Front grill with auto louvers



Variable Speed Controller



Controller for PAC20

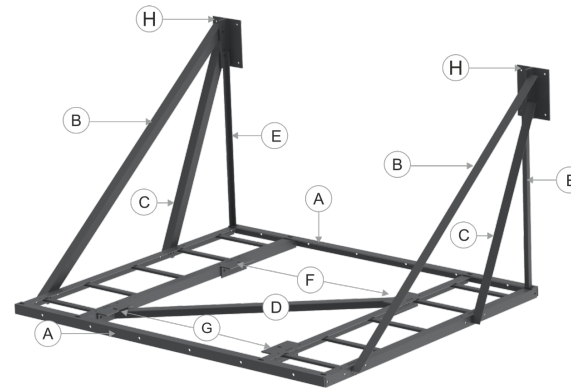

Wall mounting metal stand



Metal Trolley

Industrial air cooling: New clients addition during Q1FY22

Working with esteemed brands

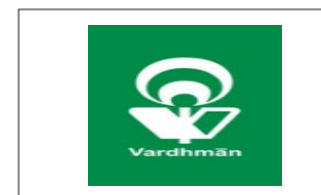

and many more...

New Campaign

For Commercial air coolers (Movicool)

जब भी, जहां भी
करना हो कूल सिम्फनी का
मोविकूल

Objective:

To create awareness about the Movicool range of air coolers & communicate its usage in various sorts of large spaces.



Afaqs

Symphony's latest spot aims to create awareness about new range of air coolers for large spaces

Indian multinational air-cooling company Symphony has launched a new campaign, titled 'Symphony ka Movicool', to introduce its new ...

29-Mar-2021



Brand Equity

Symphony launches new campaign for new range of air coolers

Symphony Ka Movicool jingle has been conceptualized to strike a chord with the audience. The simple yet catchy music was created after a lot of ...

25-Mar-2021





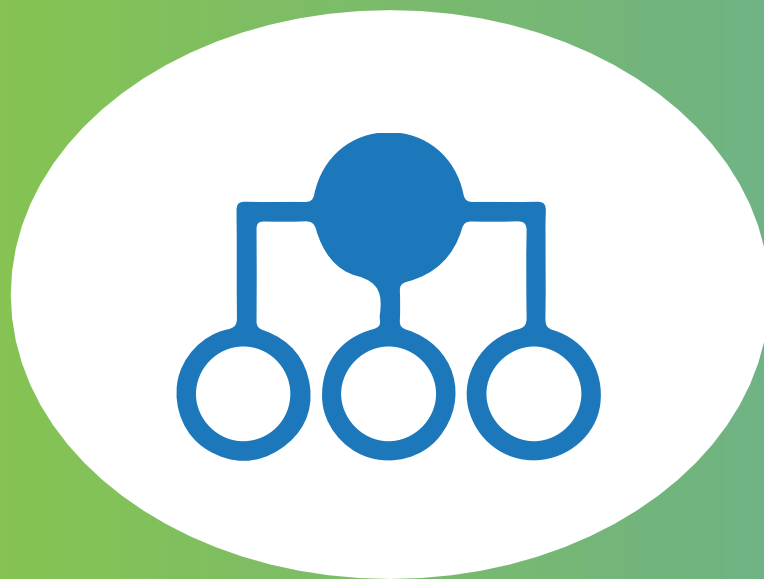

New Launches - Subsidiaries

New launches - Climate Technologies Pty. Ltd

Australia: Roof mounted air coolers



EAC

- ✓ 2 cabinet sizes, Reduce 10 SKUs of existing range.
- ✓ Low height, Sits snug on the roof.
- ✓ Installation compatible with all existing products.
- ✓ 3 different colours to match roof colours

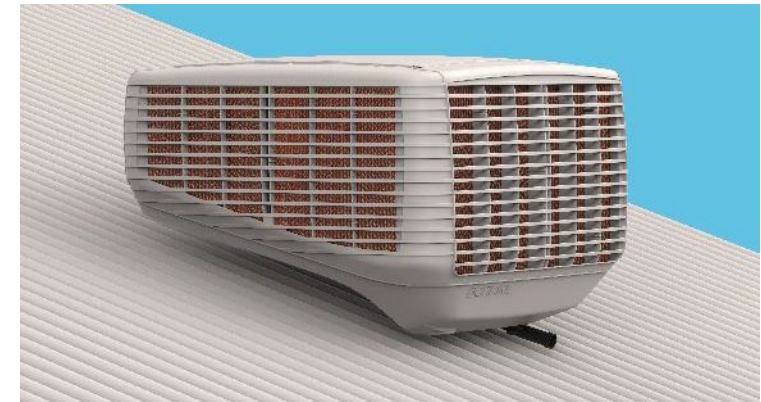

New launches – Bonaire USA (BUSA)

USA: Household air coolers



Duke

- ✓ All in one including, ventilation, humidification and purification.
- ✓ Full function remote with 7.5 hours timer
- ✓ Fully closeable horizontal louvers
- ✓ 3 wind speeds with auto vertical louver swing
- ✓ Two air delivery modes
- ✓ High Efficiency Cooling Pads
- ✓ Dust filters

New launches - IMPCO, Mexico

Window air coolers



R28SW

- ✓ New Control Panel Design
- ✓ Rust free plastic side panels
- ✓ Float valve for uninterrupted cooling
- ✓ High efficiency cooling pads
- ✓ Auto Vertical Swing
- ✓ Fully closeable horizontal louvres

R38W

- ✓ New Control Panel Design
- ✓ Rust free plastic side panels
- ✓ Float valve for uninterrupted cooling
- ✓ High efficiency cooling pads
- ✓ Auto Vertical Swing
- ✓ Fully closeable horizontal louvres

New launches - IMPCO, Mexico

HT Series air coolers



SHT Movil

- ✓ Weatherproof engineering plastic
- ✓ High efficiency cooling pads
- ✓ Easy cleanable water tank
- ✓ Free installation kit
- ✓ Fully closable louvers

SHTMovilXL

- ✓ Weatherproof engineering plastic
- ✓ High efficiency cooling pads
- ✓ Easy cleanable water tank
- ✓ Large water tank capacity
- ✓ Fully closable louvers

New launches - GSK, China

Household air coolers



CROWN i

- ✓ All in one including, ventilation, humidification and purification.
- ✓ 3-side high efficiency cooling pads
- ✓ Full function remote with 7.5-hour timer
- ✓ Removable Tank (Partial)
- ✓ Chill trays for enhanced cooling
- ✓ Dust filters



CROWN-M

- ✓ All in one including, ventilation, humidification and purification.
- ✓ 3-side high efficiency cooling pads
- ✓ Removable Tank (Partial)
- ✓ Chill trays for enhanced cooling
- ✓ Dust filters

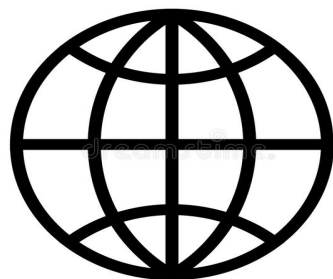

D2C Brand Store

Launch of Symphony D2C Brand store

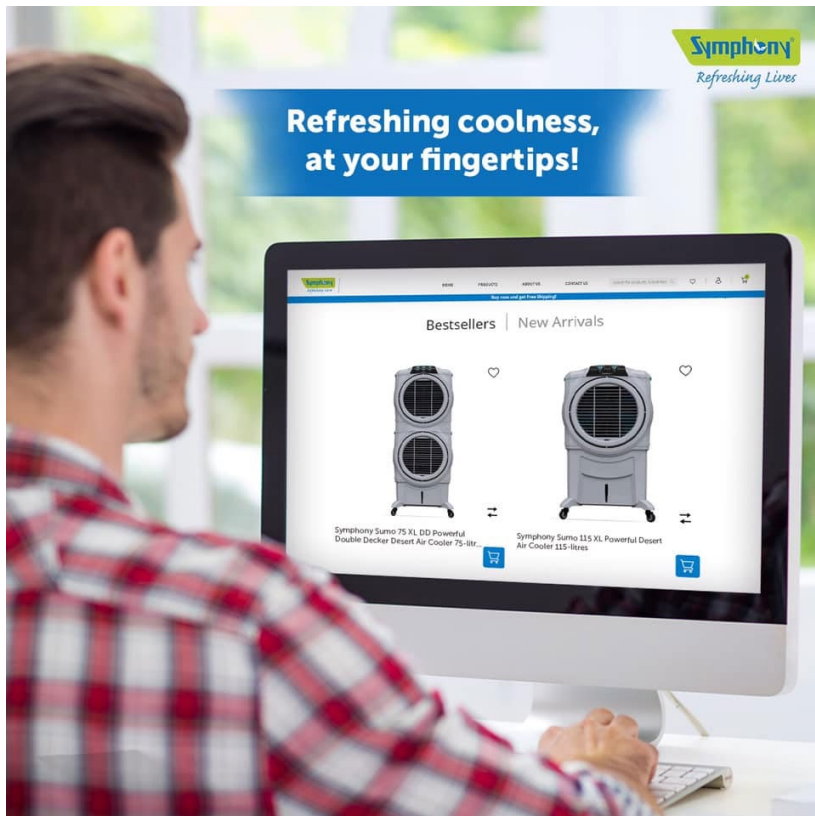

With rising internet penetration in India and the ongoing digitalization of modern life, shopping through e-commerce platforms has seen exponential growth.

Leveraging this trend and with an aim to strengthen our digital presence, we launched a new website in India with e-commerce functionality.

Our customers now have a new channel to browse through our wide range of air coolers and purchase them from the convenience of their homes throughout the year!

Launch of Symphony D2C Brand store

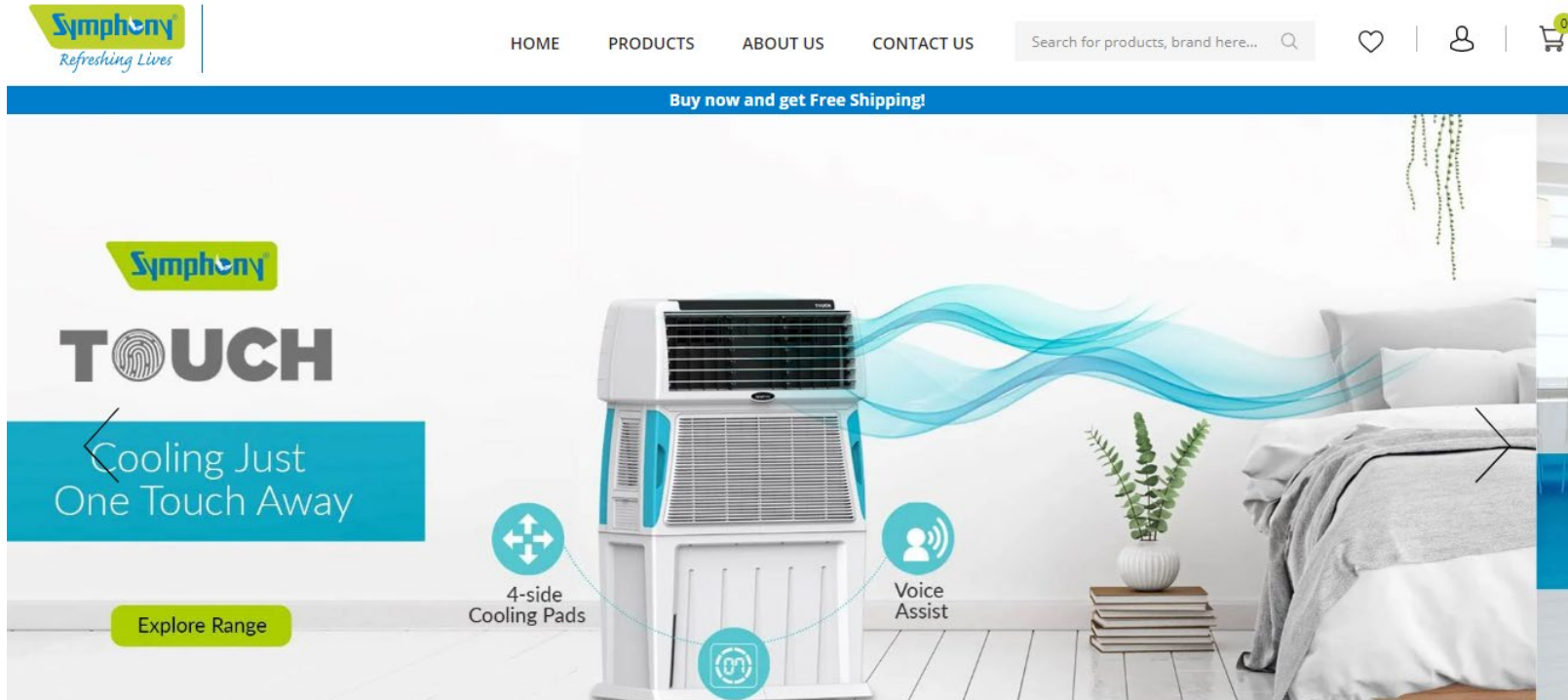

<https://www.symphonylimited.com/>

Superior user experience and convenience

HOME PRODUCTS ABOUT US CONTACT US Search for products, brand here

Symphony Diet 3D 20i Tower Air Cooler 20-litres with Magnetic Remote

In Stock Be the first to review this product

Price ₹7,991.00 ~~₹8,999.00~~ **11% OFF**
You save ₹1,008.00 on this purchase

Quick Overview

- Large 20 L tank capacity
- For rooms up to 13 m²
- i-Pure technology
- High efficiency honeycomb pad
- Consumes 145 watts* only
- Free Shipping

No Return Policy

Quantity: Availability:

Share

Pop-up TouchScreen
Easy to Use
Touchscreen Control Panel

3D Cooling
3-Side Honeycomb Cooling Pads
for Superior Cooling Experience

3D Cooling
3-Side Honeycomb Cooling Pads
for Superior Cooling Experience



Quarterly Financials

Financials: Quarterly

Consolidated (Rs Cr)

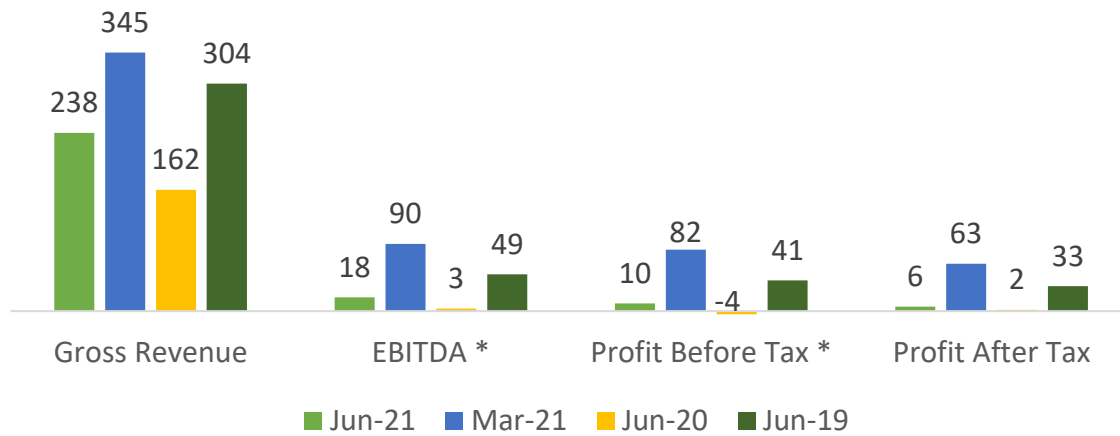

Standalone (Rs Cr)

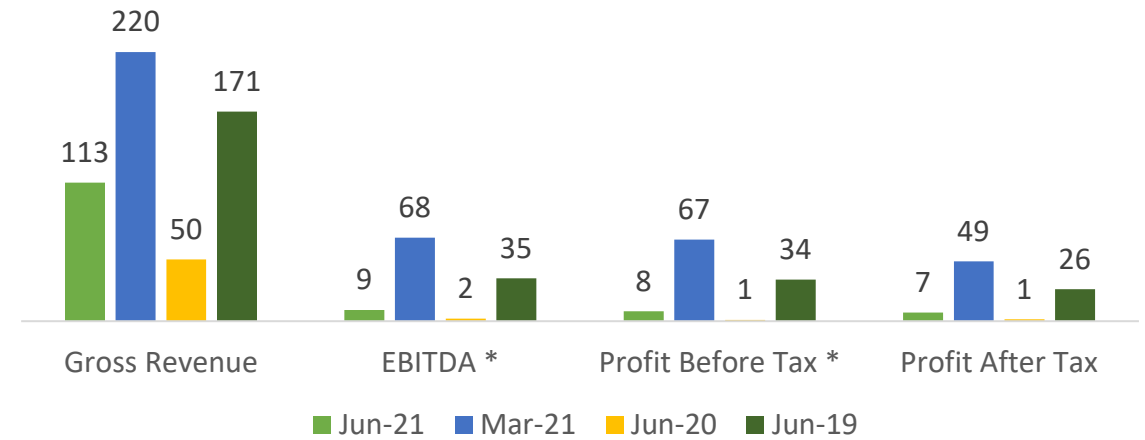

Gross Margin (%)

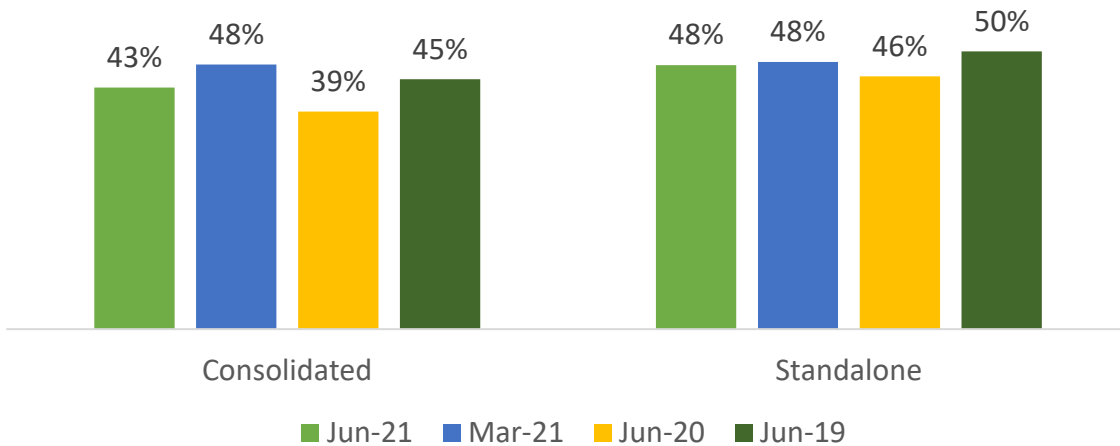

EBITDA Margin (%)

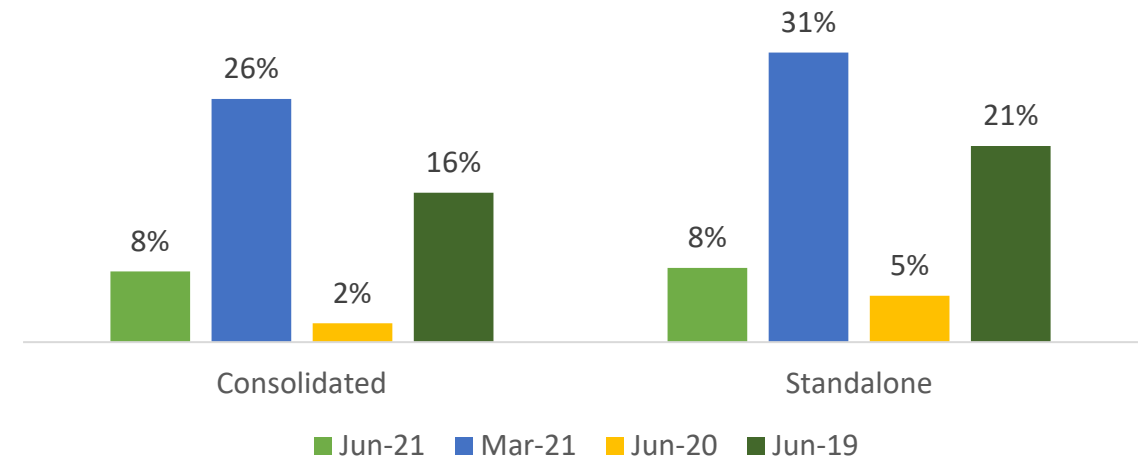

*Excluding exceptional item. Gross Revenue include other income.

Geographical break up of Sales

Revenue (Rs Cr)

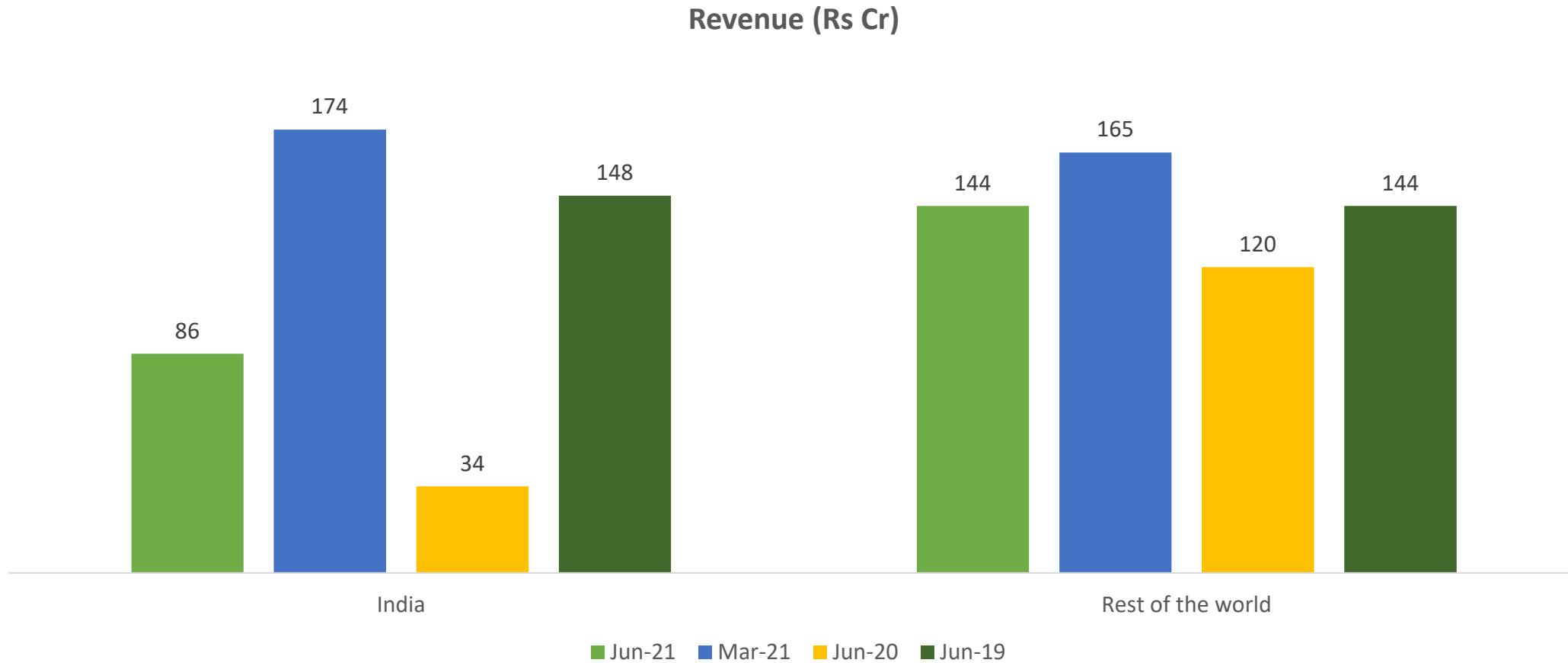

Note: June-2020 & June-2021 quarters have been impacted by lockdown due to COVID-19.

Treasury (Rs. In Cr.)*

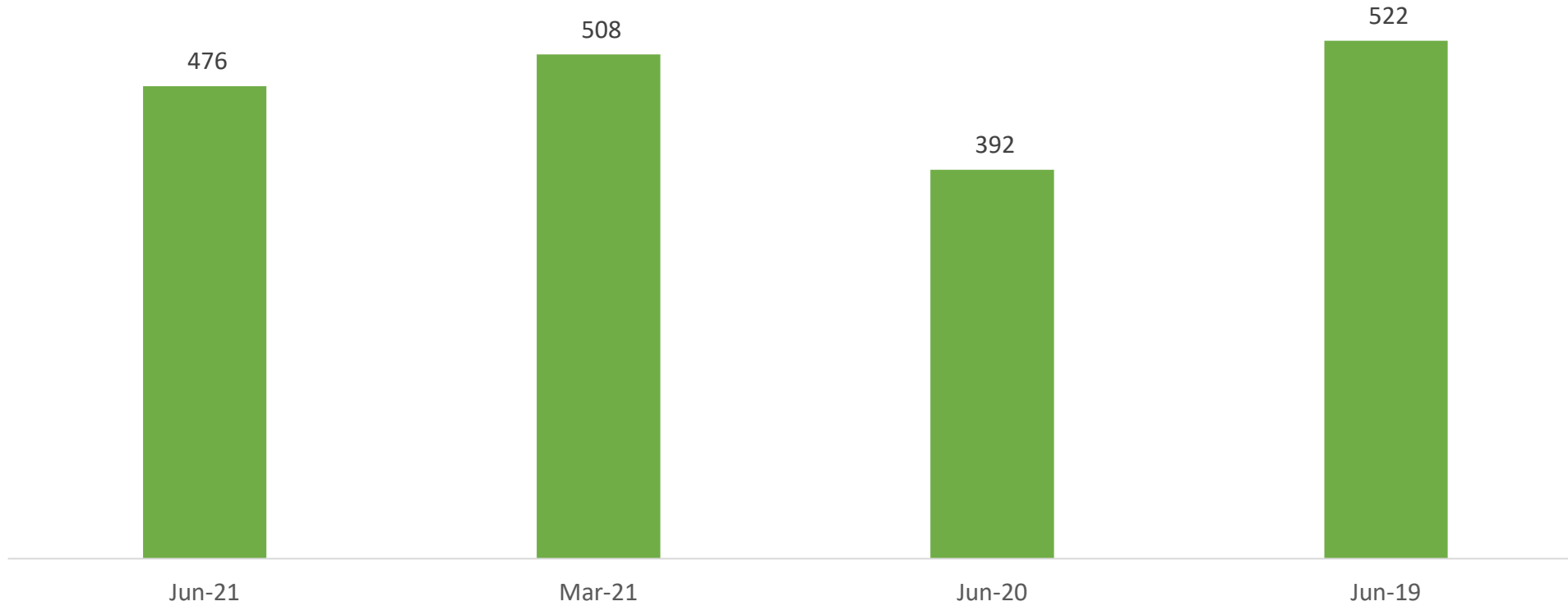

* Excluding Equity Investments in and Loans to Subsidiaries.



Refreshing Lives

www.symphonylimited.com

MEXICO

Impco S de R L de C V

AYAX 611, Parque
Industrial Kalos
Guadalupe, Guadalupe
N L, Mexico 67205

CHINA

**Guangdong Symphony
Keruilai Air Coolers Co. Ltd.**

Taiying Industrial Area,
Hongmei Town, 523160
Dongguan,
Guangdong, China

AUSTRALIA

**Climate Technologies
Pty. Ltd.**

26 Nylex Avenue
Salisbury South SA
5106
Australia

USA

Bonaire USA LLC

3774, West Cheyenne
Avenue, North Las Vegas,
Nevada, 89032, USA

INDIA

Symphony Limited

Symphony House, FP12-TP50 Bodakdev, off SG Highway,
Ahmedabad 380059

Contact

Phone: +91-79-66211111

Email: investor@symphonylimited.com