

REF:NS:SEC:
20th February, 2024

National Stock Exchange of India Limited
"Exchange Plaza", 5th Floor,
Plot No.C/1, G Block
Bandra-Kurla Complex
Bandra (East), Mumbai 400051.

BSE Limited
Phiroze Jeejeebhoy Towers,
Dalal Street, Fort,
Mumbai 400001.

Bourse de Luxembourg
Societe de la Bourse de Luxembourg
Societe Anonyme/R.C.B. 6222,
B.P. 165, L-2011 Luxembourg.

London Stock Exchange Plc
10 Paternoster Square
London EC4M 7LS.

Sub: SEBI (Listing Obligations and Disclosure Requirements) Regulations 2015 - Additional Presentations to be made at the Analyst/Institutional Investor Meeting

This is further to our letter bearing REF:NS:SEC dated 9th February, 2024 wherein we had given you an advance intimation of the Schedule of Analyst or Institutional Investor Meeting(s) with the Company in terms of Regulation 30(6) read with Schedule III of the Securities and Exchange Board of India (Listing Obligations and Disclosure Requirements) Regulations, 2015.

In this regard, we would like to mention that the Presentation(s) which was sent to the Stock Exchanges vide our letter bearing REF:NS:SEC dated 14th February, 2024 and which is available at the Weblink: <https://www.mahindra.com/sites/default/files/2024-02/MM-Q3F24-Analyst-Meet-%E2%80%93Presentations-deck-%E2%80%9314th-Feb-2024.pdf> would be made at the **Kotak Investor Conference - Keynote Session** scheduled to be held on on 21st February, 2024 in **Mumbai**.

In addition to the above, the Presentations, which are enclosed, would also be made during the aforesaid **Kotak Investor Conference - Keynote Session** scheduled to be held on 21st February, 2024 in Mumbai.

The same is also being uploaded on the Company's website and can be accessed at the weblink: <https://www.mahindra.com/sites/default/files/2024-02/Presentation-Kotak-Investor-Conference-EV.pdf> and <https://www.mahindra.com/sites/default/files/2024-02/Presentation-Kotak-Investor-Conference-Deliver-Scale.pdf>

Please note that no unpublished price sensitive information is proposed to be shared by the Company during the aforesaid Investor Conference/Keynote Session.

Kindly take the same on record.

Yours faithfully,
For **MAHINDRA & MAHINDRA LIMITED**

NARAYAN SHANKAR
COMPANY SECRETARY
Encl.: as above

Making India the global EV hub

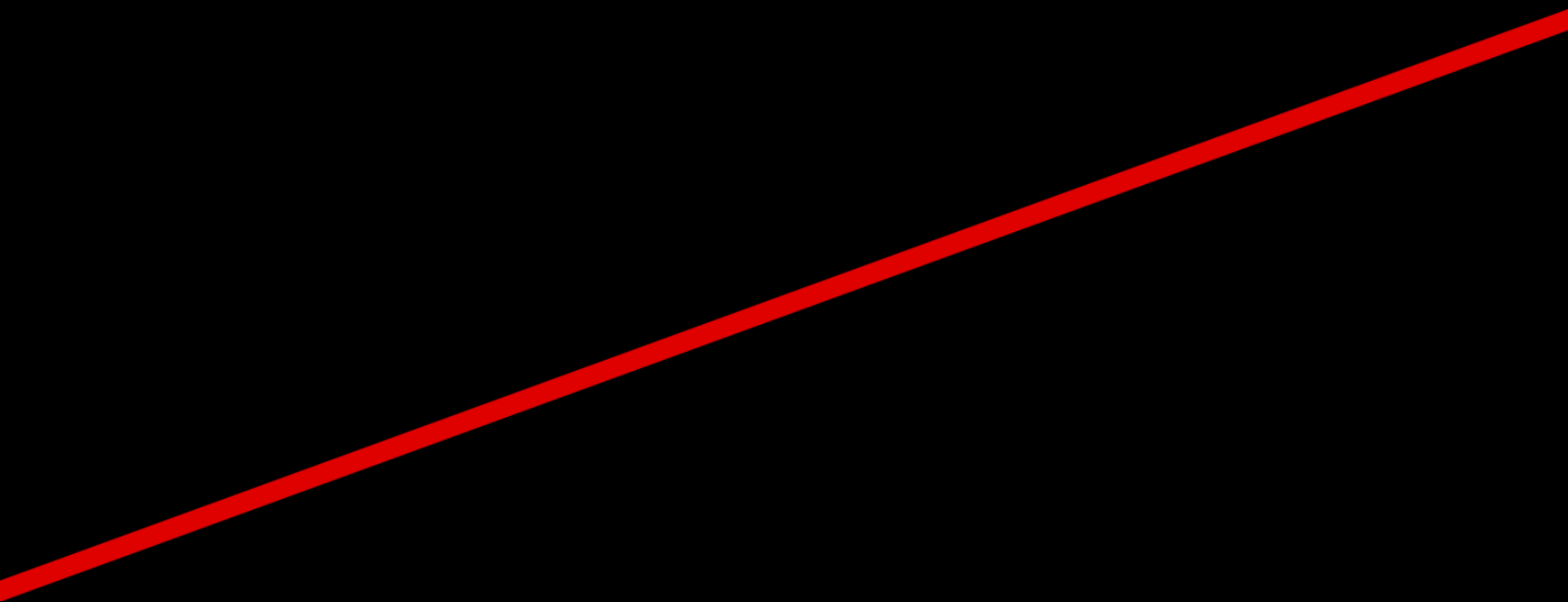

India has the potential to be the EV export hub for the world

Scale



- Largest 2W & 3W market
- 3rd largest PV market in the world

World Class Products



- Indian OEMS winning against the best in the world in India
- XUV700 & Scorpio N gaining share across the world

Focused Policies



- FAME – INR 10000 Cr outlay¹
- PLI – INR 75k Cr commitment²
- EV sales flattening in countries where policies are withdrawn before scale

Challenges in the EV space today

**EV Penetration
in India¹**

2%

4W Penetration

16.4%

3W Penetration

Key Challenges

- ICE converted EVs today with about 20-30% higher upfront cost
- Range anxiety and low availability of fast charging infrastructure
- Concerns around clarity and credibility of information

Opportunities over next 5 years

OEMs

- Grounds up disruptive products
- 10-14 born EVs by 2026 ¹
- INR 75k Cr commitment vs INR 42.5k Cr estimate for PLI ²
- Real world usage from 250 to 450+Km
- Seamless and immersive customer experience

CPOs & Oil Companies

- Development of charging ecosystem
- 135 EVs per charger at present ³
 - Niti Aayog Target 8 EVs per charger
 - 12k public chargers today ⁴
 - Oil companies – INR 800Cr subsidy for 10000 chargers ⁵

Government

- Consistent focus on BEV policies till scale
- Higher affordability, cost of battery expected to reduce with scale
- Policies to support charging ecosystem

Source

1 Media Reports (Autocar India, Economic Times), HIS

2 Press Information Bureau

3 Media (The Hindu Businessline)

4 Ministry of Heavy Industries

5 Media (Economic Times), Press Information Bureau

Segment with fastest electrification: Last Mile Mobility

Last Mile Mobility Industry Electrification ¹

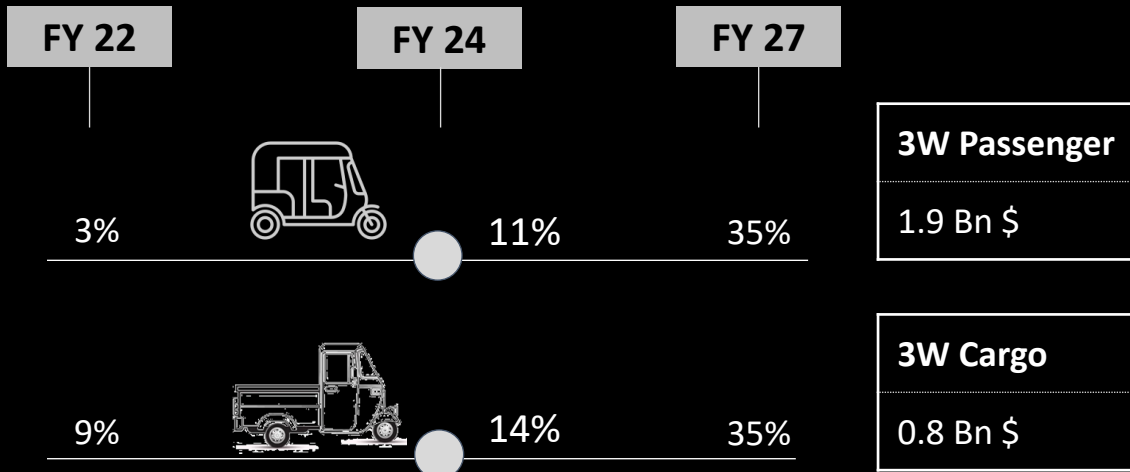

Electrification Drivers

- **Positive consumer economics** – Favourable TCO for e3W
- Major e-commerce logistics players plan to **decarbonize supply chain** for meeting emission targets

Demand drivers:

Passenger

- Higher ride-share / ride-hailing services
- Better infrastructure (roads and public transport)

Goods

- e-commerce to grow 2x from 2021 to 2025 ²

Source

¹ Electrification data - Bain & Co, Mckinsey

² Euromonitor



M&M EV Story

M&M – Leaders in the Indian EV last mile mobility space



#1

3W EV player in India



60%

Market share in EVs –
FY 24 (Apr-Dec'23)



140K+

Electric Vehicles
on road

TREO	ALFA	ZOR GRAND
<p>TREO Electric</p> 	<p>ALFA DX Electric</p> 	<p>ZOR GRAND DV Electric</p> 
<p>TREO PLUS Electric</p> 	<p>ALFA DX CNG</p> 	<p>ZOR GRAND DV PLUS Electric</p> 
<p>TREO YAARI Electric</p> 	<p>ALFA PLUS Electric</p> 	<p>ZOR GRAND DV PLUS Electric</p> 
<p>TREO ZOR Electric</p> 	<p>ALFA PLUS CNG</p> 	<p>ZOR GRAND PU Electric</p> 
	<p>E ALFA SUPER Electric</p> 	
	<p>E ALFA CARGO Electric</p> 	

M&M ready to disrupt global passenger EV market starting 2024



MAHINDRA ELECTRIC
SUVs

Logo Reveal video



MAHINDRA ELECTRIC
SUVs

MASTER BRAND

mahindra^{Rise}

Internal Combustion Engine

Born Electric Vehicle

CATEGORY BRAND



EXPLORE THE IMPOSSIBLE



INFINITE POSSIBILITIES

PLATFORM BRAND

ADRENEX
CONNECT

INGLO
POWERFULLY HUMAN

LEAD PRODUCT BRAND

BOLERO

XUV

SCORPIO

THAR

BE

XUV.e

THAR.e

SCORPIO.e

BOLERO.e

Le Chalaang Video (Hindi Version)

Our range of Born Electric Vehicles



INGLO

mahindra

Born Electric Platform

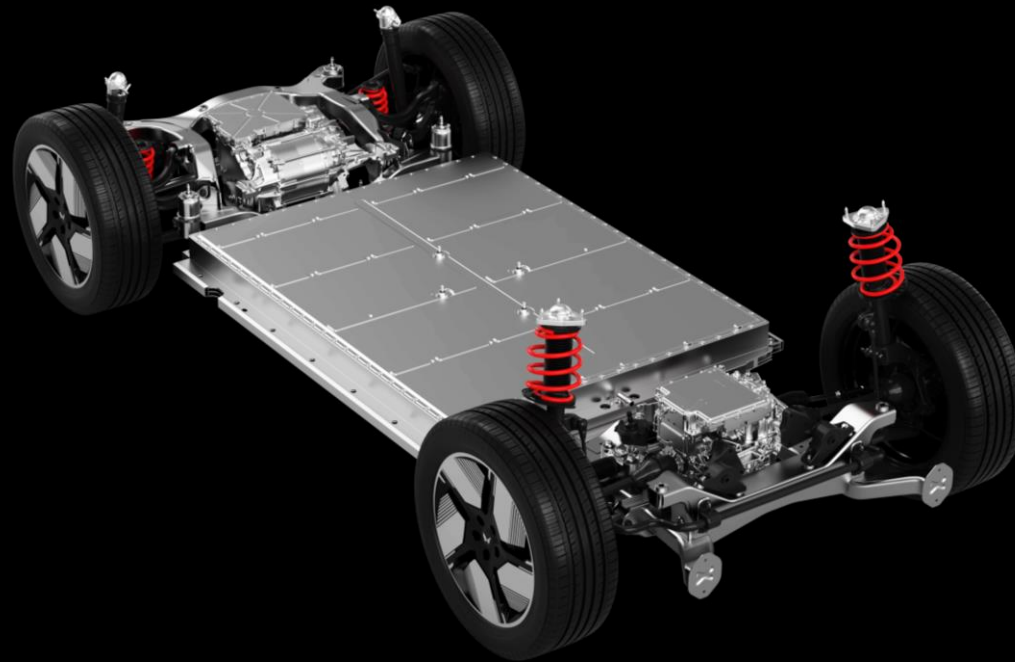

mahindra

- SUV Modular Platform Architecture
- Performance, Range
- Safety
- Dynamics
- High Compute Power
- Intuitive HMI

INGLO – Modular SUV Platform

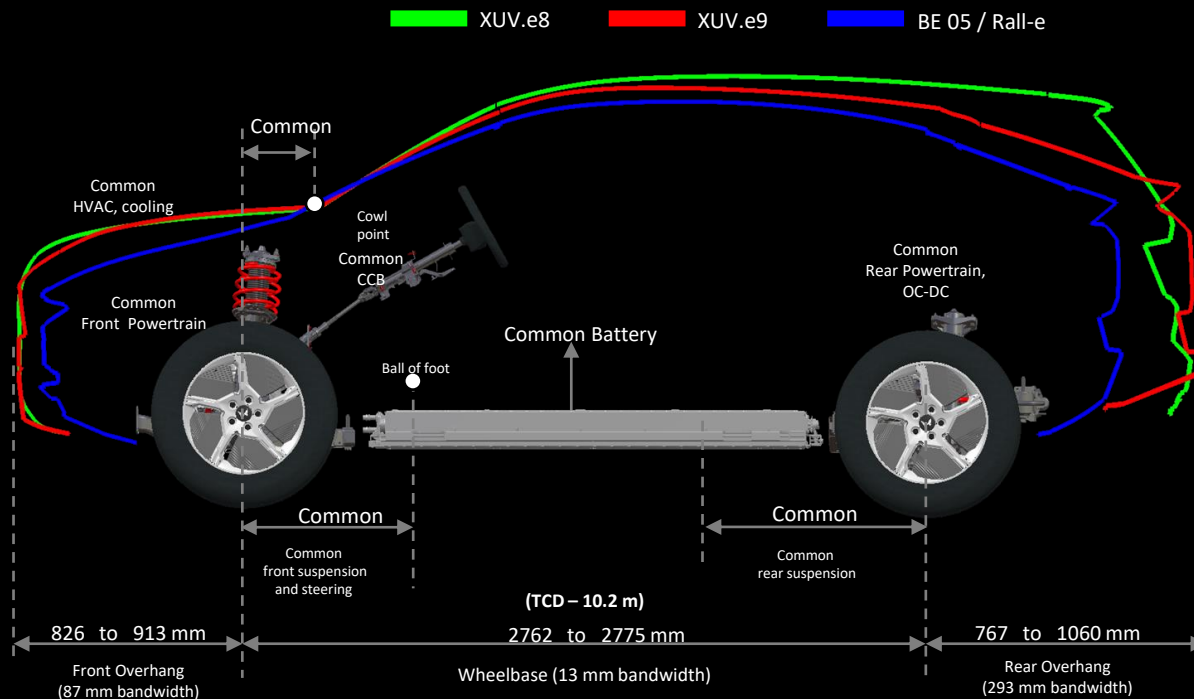

15th Aug 2022

- Lightest 7-seater skateboard
- World-class crash performance
- Best-in-class BIW Stiffness
- Optimized wheelbase
 - Battery size
 - Vehicle dynamics
 - Best-in-class TCD
- Rear Wheel Drive, All Wheel Drive

INGLO – High Performance Electric Powertrain

Front Powertrain

80 kW, 135 Nm

(Production part – VW)

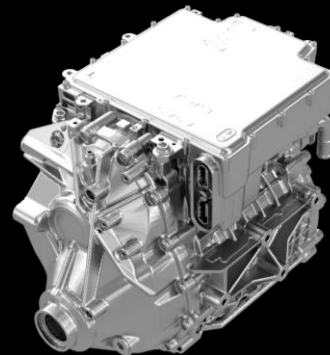

Rear Powertrain

210 kW, 535 Nm

(100 % tooled-up – VW)



Rear Powertrain

170 kW, 380 Nm

(100 % tooled-up – VALEO)



- Compact 3-in-1 Powertrain
- 100 % tooled-up, functional tests underway
- Performance calibration in progress

Tech Features

Seamless Edge to Edge Display



- 3 x 12.3" screens
- High resolution display – 1920 x 720
- LOCA Bonding
- Oleo-phobic

Immersive Surround Sound 16 speakers



- DOLBY ATMOS
- Audio Levelizer
- Virtual Venues
- VESS
- Vehicle Noise Cancellation

Connectivity



V2X, 5G



Our BEV is a concert hall on wheels

We have partnered with **Dolby Atmos** and **Harman Kardon** to bring unmatched 3D immersive sound experience in our BEV



- Dolby ATMOS - **first in India**
- Sounds can now be **interpreted as 3D objects**
- Allows discrete audio elements in a **three-dimensional sound**
- **Adapts to any playback environment**



- **16-speaker system** with **Quantum Logic Immersive (QLI)** surround sound - **first in India**
- **QLI** redistributes the individual audio streams to specific speakers
- Other Key Features – Vehicle Noise Cancellation; AudioLEVELIZER to level amplifications; Clari-Fi for music restoration, etc

Sonic Identity & Brand Anthem for BEVs by AR Rahman



Testing & Validation under all conditions, India & globally



State of the art dedicated manufacturing facility at Chakan



Dedicated Assembly Line



95% Automation, 40+ Robots



State of the art battery assembly line



Coming in December 2024

THAR.e

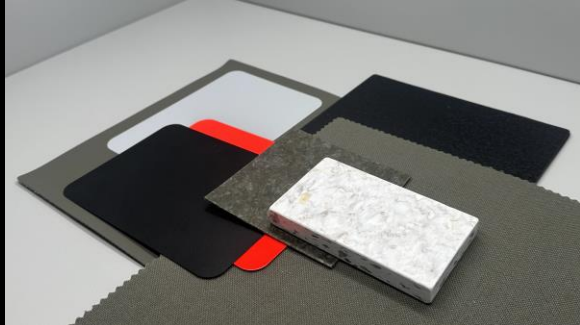



MAHINDRA ELECTRIC
SUVs

Questions?

Mahindra & Mahindra Limited

~~Chasing growth~~ *Deliver Scale*

Kotak Investor Conference

February 2024

mahindra^{Rise}

Key Messages

- There is unprecedented momentum in the Indian economy ... The **Mahindra group** has meaningful presence in the key sectors that will propel India's economy
- With a strong culture, an exceptional governance track record and a history of value creation, the group is poised to build on India's growth
- Our focus is to “Deliver scale” in all our businesses in the segments they operate in
- We look at our businesses in 3 buckets ... **A)** Auto & Farm which are market leaders **B)** Mahindra Finance & Tech M which are scale businesses & **C)** “Growth Gems” which have significant potential to scale
- We believe that Auto & Farm should lead the Industry globally on Product innovation and Technology
- We think Mahindra Finance & Tech M can unlock their full potential through operational excellence
- We have set aggressive growth goals for the “Gems” to deliver 5X their value in 3-5 years
- We have a mix of actions underway in each of these businesses ... We are executing these through disciplined capital allocation and a strong commitment to 18% ROE & 15% EPS growth as a group

OUR PORTFOLIO ... TODAY

AUTO



PASSENGER AND
COMMERCIAL VEHICLES



LAST MILE MOBILITY



ICONIC MOTORCYCLES



TRUCKS & BUSES

FARM



TRACTORS AND AGRI
SERVICES



FARM MACHINERY

SERVICES



FINANCIAL

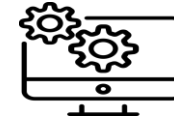

TECHNOLOGY



HOSPITALITY



REAL ESTATE



LOGISTICS

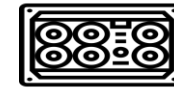

AUTO COMPONENTS
AUTO RECYCLING



RENEWABLE
ENERGY



AEROSTRUCTURES
AND SAFETY SYSTEMS

OUR PORTFOLIO IS ALIGNED WITH INDIA GROWTH

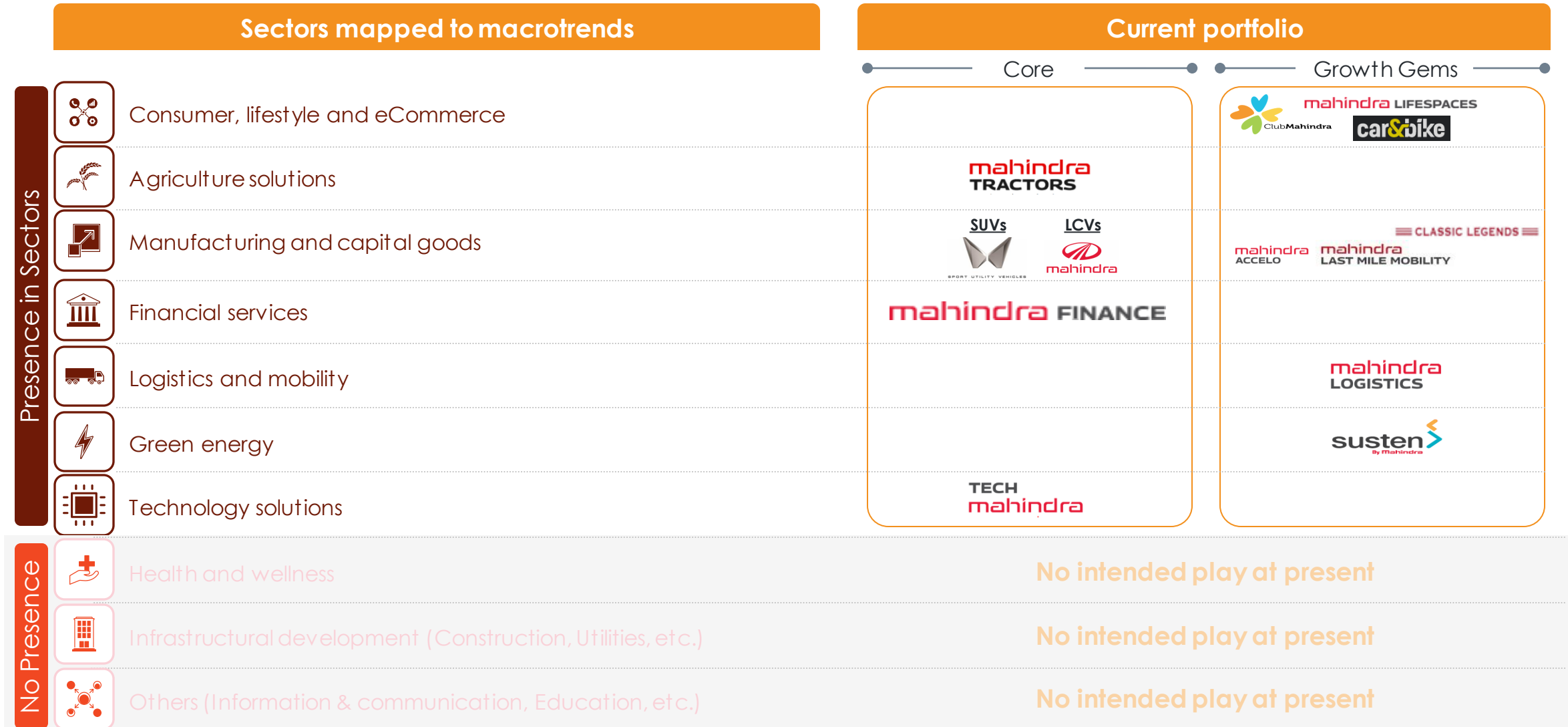

Note: Others includes Extraction, Publishing and broadcasting activities, Education, Telecommunications, Information and communication

OUR DNA ... STRONG GOVERNANCE & CULTURE

Set Governance Standards

- Key businesses listed on stock exchanges and supervised by independent boards
- Uniform core values and code of conduct
- Strong ERM process led by a risk council
- Highest standards of disclosure
- Reputed auditors (KPMG) covering group
- Multiple recognitions by reputed bodies



Strong Credentials

Enhance Lives of Communities

Rural

- ~1MM low income houses financed
- 200 agri centers helping 800,000+ farmers
- 2 MM+ farmers empowered ... Krishe app

Urban/Semi Urban

- 100,000+ e3Wheelers in major cities
- \$9MM scholarships provided for education

Women

- 1MM yrly target for women empowerment
- 550,000+ women educated

Doing Good

Tangible Actions on Climate

- Detailed sustainability plans by business
- Greening Ourselves ... Net Zero by 2030**
- FY23: 10% YOY Scope 1&2 emission ↓, Water Positive, 85% Zero Waste to Landfill

Decarbonizing our Industries

- Transitioning to a green portfolio
- Committed to net zero supply chain and promoting Industry circularity

Rejuvenating Nature

- Haryali Initiative : 22MM+ trees planted

M&M: Carbon Neutral by 2040

WE HAVE A HISTORY OF VALUE CREATION

PAT Lens: History of value creation with accelerating trajectory

PAT* (Rs. Cr.) FY2002-2023

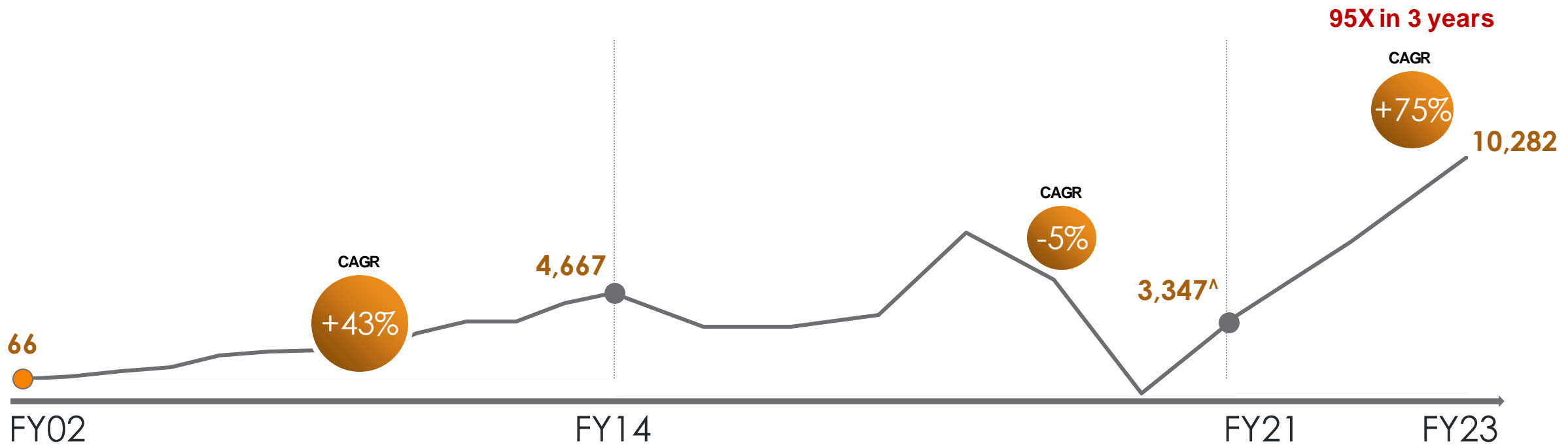

* After Exceptional Items after Non-Controlling Interest

[^] PAT after EI for continuing operations

STRATEGIC IMPERATIVES

FY21

Capital
Allocation

FY22 - 24

Pivot
to growth

FY25 - 27

Deliver Scale



Capitalize on Market
Leadership



Unlock full potential



5X growth challenge



Disciplined capital
allocation

DELIVER SCALE

Capitalize on Market Leadership

Auto



mahindra
LAST MILE MOBILITY

CLASSIC LEGENDS

Capitalize on Market Leadership

Farm

mahindra
TRACTORS

mahindra
AGRI BUSINESS

mahindra
Farm Machinery

Unlock full potential

Services

mahindra
FINANCE

TECH
mahindra

mahindra
LOGISTICS

mahindra LIFESPACES



mahindra
ACCELO

car&bike

susten
by Mahindra

mahindra
AEROSPACE

Growth Gems: 5X Challenge

CAPITALIZE ON MARKET LEADERSHIP ... AUTO & FARM

AUTO



Customer obsessed brands



Propel ICE SUVs with cutting edge products



Pioneer category creative E SUVs



Build a CV Moat



Go global

FARM



Build a domestic fortress



Significantly grow international business



Pioneering technology leadership



Scale Farm Machinery India exponentially



Leverage partnerships

1. At consolidated level
2. SUV Revenue market share
3. Does not include M&A

UNLOCK FULL POTENTIAL ... MAHINDRA FINANCE & TECH M

MAHINDRA FINANCE



Improve asset quality



Digital transformation



Growth through diversification



High-impact Ecosystem partnerships

Tech Mahindra



Drive 300 bps margin expansion



Lead the market and drive 5G proliferation



Grow new age offerings

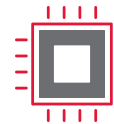

Augment Deep-Tech



Drive synergy from portfolio companies

1. At consolidated level
2. SUV Revenue market share
3. Does not include M&A

GROWTH GEMS | 5X GROWTH



mahindra LIFESPACES

- >35 msf of residences, >5000 acres of integrated cities built
- Fully green portfolio since 2014
- Launched India's first net zero energy and waste projects



susten by mahindra

- India's largest InvIT in renewable space
- IPP portfolio of 1.5 GWp+, 2.6 B+ units annually
- Strategic investor OTPP onboarded for 30% stake



mahindra LAST MILE MOBILITY

- No 1 electric three-wheeler company with >50% share
- Significant investments from IFC and IJP
- Collaborated with Attero for EV battery recycling



ClubMahindra

- No.1 vacation ownership company outside USA
- Crossed 100 resorts, 5000 keys, 2.86 million members
- India's first triple net zero resort in Madikeri





mahindra ACCELO

- Leading mobility & energy components company
- Market leader in high-end transformer components
- India's largest Vehicle Recycling Company (40+ cities)



SUMMARY ... OUR ASPIRATION

Deliver Scale

1 Leverage market leadership

 : Differentiated offering in SUVs
 : Leading product innovation

2 Unlock full potential

 : Diversified portfolio & stable asset quality
 : Grow new age offerings while executing well

3 Growth Gems 5X

4 Disciplined Capital Allocation

Consistent delivery on commitments

