



Jamna Auto Industries Ltd.

September 27, 2024

To,
BSE Limited
Phiroze Jeejeebhoy Towers,
DalalStreet, Mumbai- 400001
Maharashtra

BSE Code: 520051

To,
National Stock Exchange of India Limited
Exchange Plaza, Plot no. C/1, G Block,
Bandra-Kurla Complex, Bandra (E)
Mumbai - 400051, Maharashtra

NSE Code: JAMNAAUTO

Subject: Investors Presentation on the financial results for the quarter ended June 30, 2024.

Dear Sir/Madam,

Pursuant to the requirements of Regulation 30 and Regulation 46 of SEBI (Listing Obligations & Disclosure Requirements) Regulations, 2015, we are enclosing herewith the presentation by the Company pertaining to the financial results for the quarter ended June 30, 2024.

Kindly take the above information on records

Thanking you,
Yours Faithfully,
For Jamna Auto Industries Limited

Praveen Lakhera
Company Secretary & Head-Legal



Jamna Auto Industries Limited

Investor Presentation

Q1 FY 24-25



This presentation and the accompanying slides (the “Presentation”), have been prepared by Jamna Auto Industries Limited (the “Company”), have been prepared solely for information purposes and do not constitute any offer, recommendation or invitation to purchase or subscribe for any securities, and shall not form the basis or be relied on in connection with any contract or binding commitment whatsoever. No offering of securities of the Company will be made except by means of a statutory offering document containing detailed information about the Company.

This Presentation has been prepared by the Company based on information and data which the Company considers reliable, but the Company makes no representation or warranty, express or implied, whatsoever, and no reliance shall be placed on, the truth, accuracy, completeness, fairness and reasonableness of the contents of this Presentation. This Presentation may not be all inclusive and may not contain all of the information that you may consider material. Any liability in respect of the contents of, or any omission from, this Presentation is expressly excluded.

Certain matters discussed in this Presentation may contain statements regarding the Company’s market opportunity and business prospects that are individually and collectively forward-looking statements. Such forward-looking statements are not guarantees of future performance and are subject to known and unknown risks, uncertainties and assumptions that are difficult to predict. These risks and uncertainties include, but are not limited to, the performance of the Indian economy and of the economies of various international markets, the performance of the industry in India and world-wide, competition, the company’s ability to successfully implement its strategy, the Company’s future levels of growth and expansion, technological implementation, changes and advancements, changes in revenue, income or cash flows, the Company’s market preferences and its exposure to market risks, as well as other risks. The Company’s actual results, levels of activity, performance or achievements could differ materially and adversely from results expressed in or implied by this Presentation. The Company assumes no obligation to update any forward-looking information contained in this Presentation. Any forward-looking statements and projections made by third parties included in this Presentation are not adopted by the Company and the Company is not responsible for such third party statements and projections.

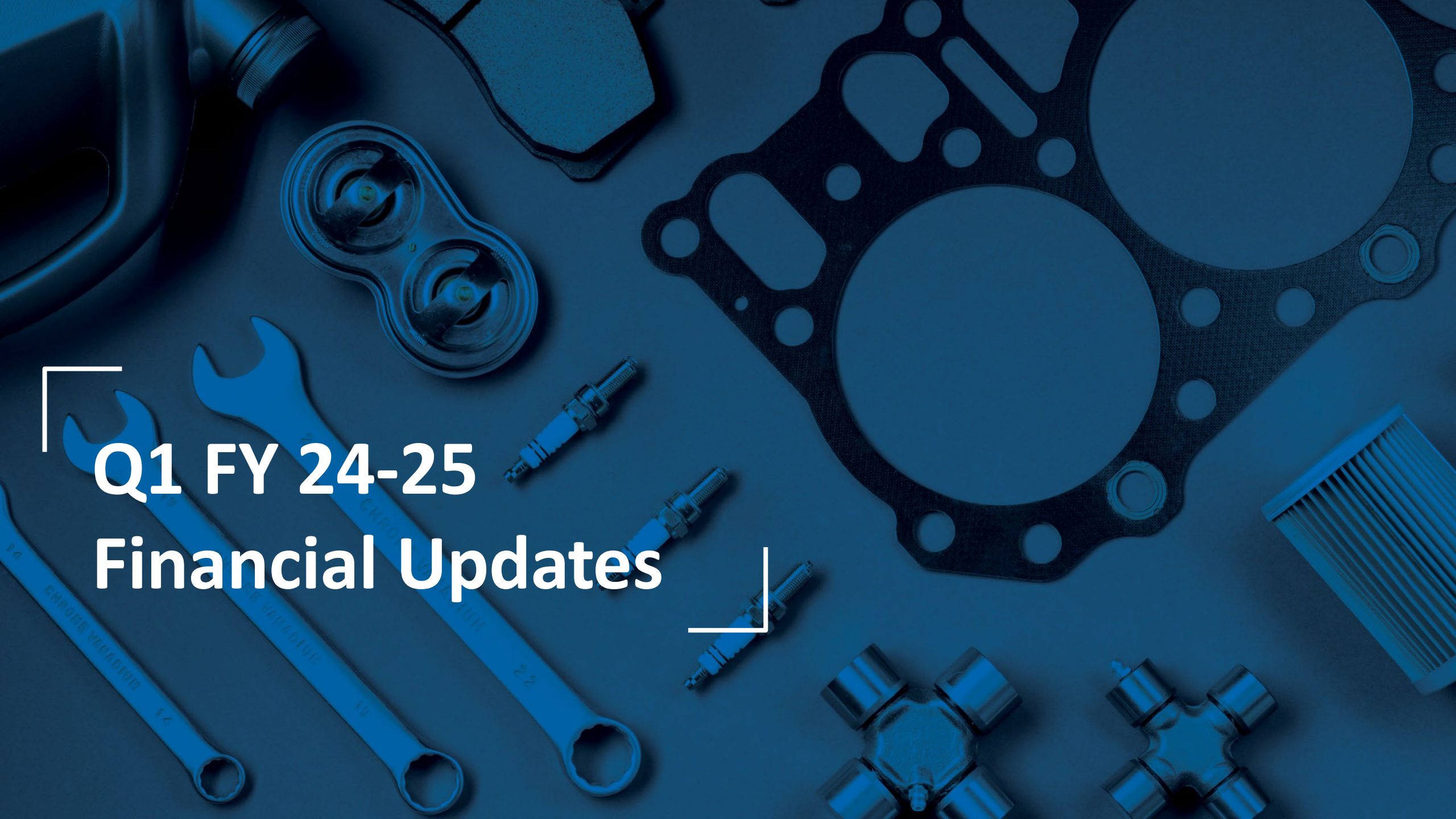

Q1 FY 24-25
Financial Updates

Financial Trends - QoQ



All figures are in INR crores

	Q1 FY 24-25	Q4 FY 24-25	Q1 FY 23-24
NET SALES	557	641	575
EBITDA	76/13.7%	89/13.9%	74/12.9%
PBT	65/11.6%	78/12.2%	63/10.9%
CASH ACCRUALS	57	65	56

Cash Accruals: PAT+ Depreciation

Profit & Loss Statement



Consolidated QoQ

All figures are in INR crores

Particulars	Q1 FY 24-25	Q4 FY 23-24	QoQ	Q1 FY 23-24	YoY
Net Sales	557	641	-13%	575	-3%
EBITDA	76	89	-15%	74	3%
PBT	65	78	-17%	63	3%
PAT	46	55	-15%	44	2%

Revenue Mix



Product Mix

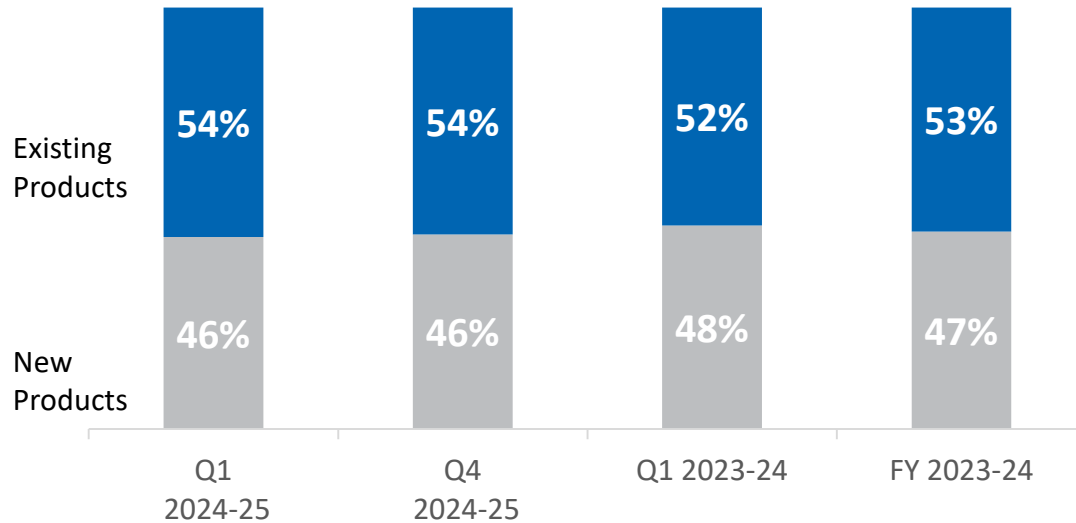

Lakshya Target: **50%** revenue from New Products by FY 2026-27

Market Mix

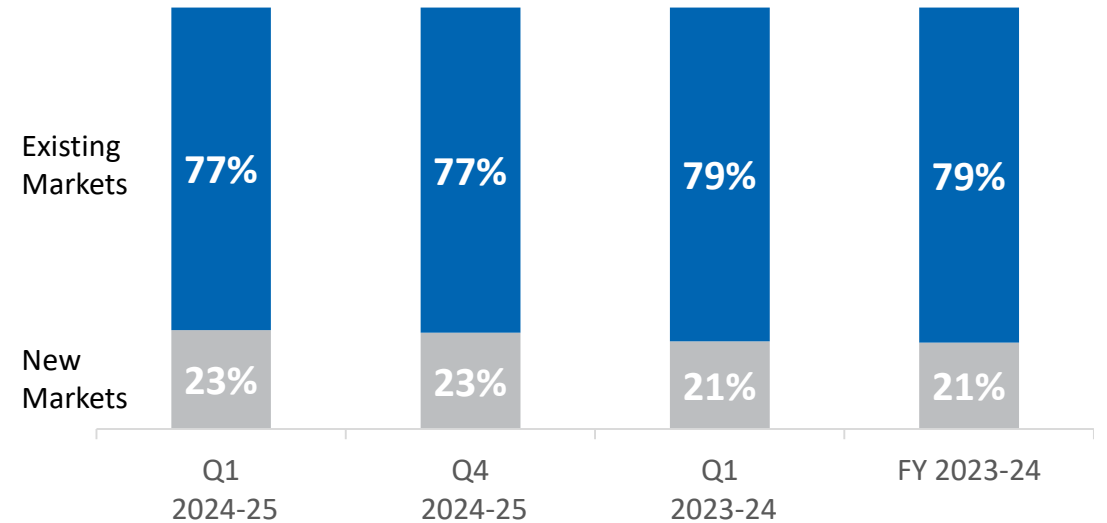

Lakshya Target: **50%** revenue from New Markets by FY 2026-27



- On July 5, 2024, the Company detected a ransomware incident at its server at Pune, India, that had affected Company's IT systems including accounting software(s). The Company acted promptly and took necessary precautions and protocols to mitigate the impact of the incident and successfully recovered/restored the data from backups with the help of cybersecurity experts. Based on further review and analysis of the data recovered the Company was able to assess that there had been no material impact on systems involved for production, sales and other operations of the Company and no price sensitive information or data was deleted or impacted as a result of this incident.
- The process of recovery of affected data and the re-installation of systems along with performing cyber security procedures took time and as a result there was a delay in submission of the unaudited financial results for the quarter ended on June 30, 2024.
- The Company has also appointed a Cyber Auditor to further assess the Company's IT systems, identify any current shortcomings and recommend any further improvements. As on date, the Company has successfully restored all the data from backups, and our systems are functioning normally, and we have not detected any further anomalies. We continue to monitor our systems closely to ensure ongoing security and stability.



Industry Highlights

Industry Highlights



All figures are in '000

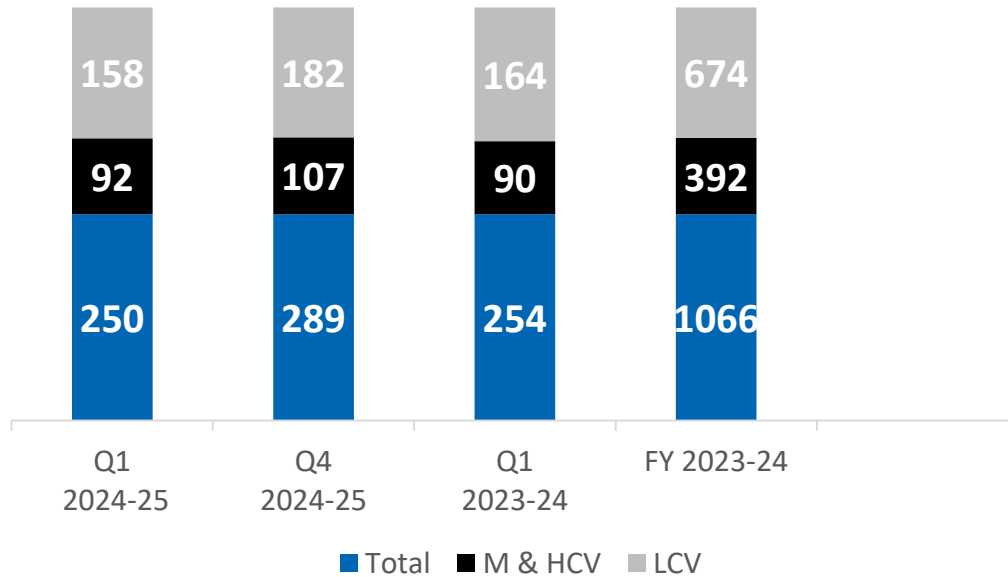

Data Source-SIAM

LCV production changes

- ↓ - Q1 FY25 vs Q4 FY24 - 13% (Decrease)
- ↓ - Q1 FY25 vs Q1 FY24 - 3% (Decrease)

M&HCV production changes

- ↓ - Q1 FY25 vs Q4 FY24 - 14% (Decrease)
- ↑ - Q1 FY25 vs Q1 FY24 - 2% Increase

For the Quarter

QoQ Change %	YoY Change %
- 13%	-3%
-14%	2%
-13%	-1%



Company Overview

JAI at a Glance



Foundation
JAI is a renowned suspension manufacturer for commercial vehicles.

World class Manufacturing Infrastructure
10 Manufacturing units including 1 In-house R&D center

- More than 16,000 touch points
- JAI Shoppe in Sanjay Gandhi Transport Nagar, Delhi which is one of the largest trucking center in India.

Manufacturing
~300+ OEM parts
~5,000+ AMI parts

Sound Financials
CRISIL A1+/AA-

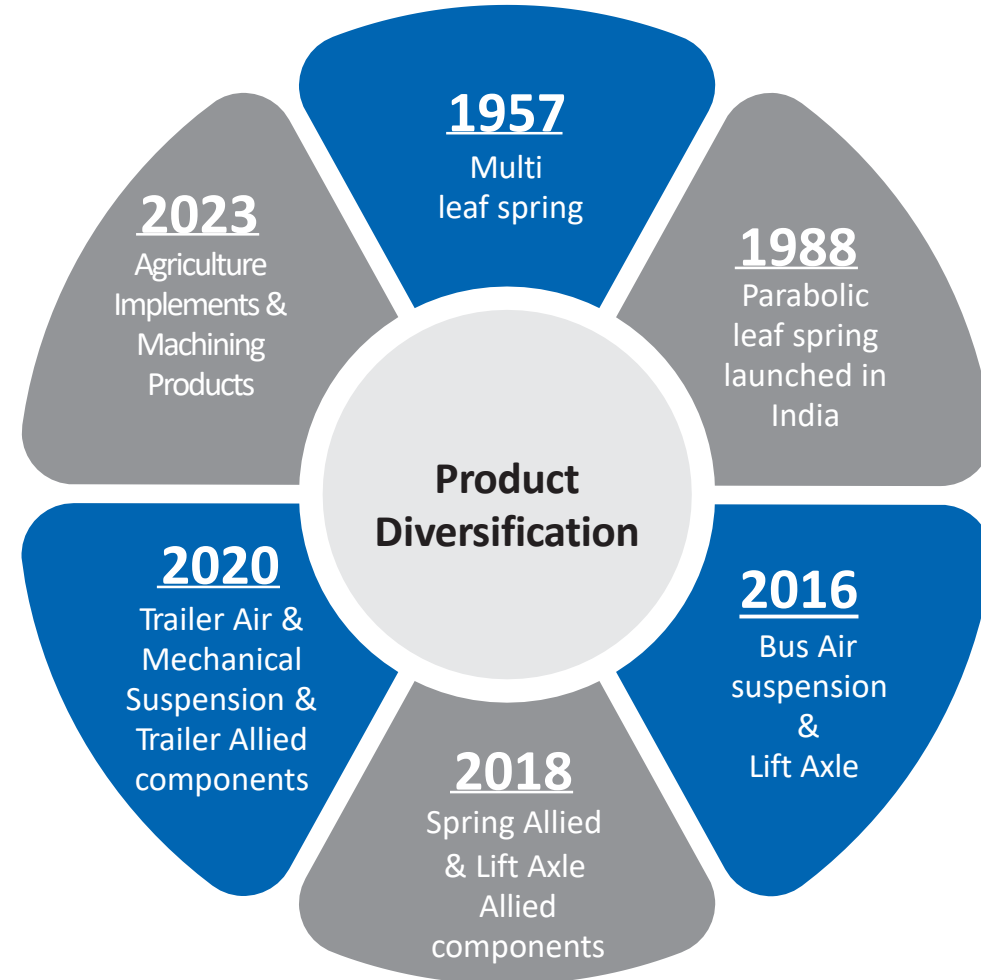

Jai's Plants : Strategically Located Across OEM Plants

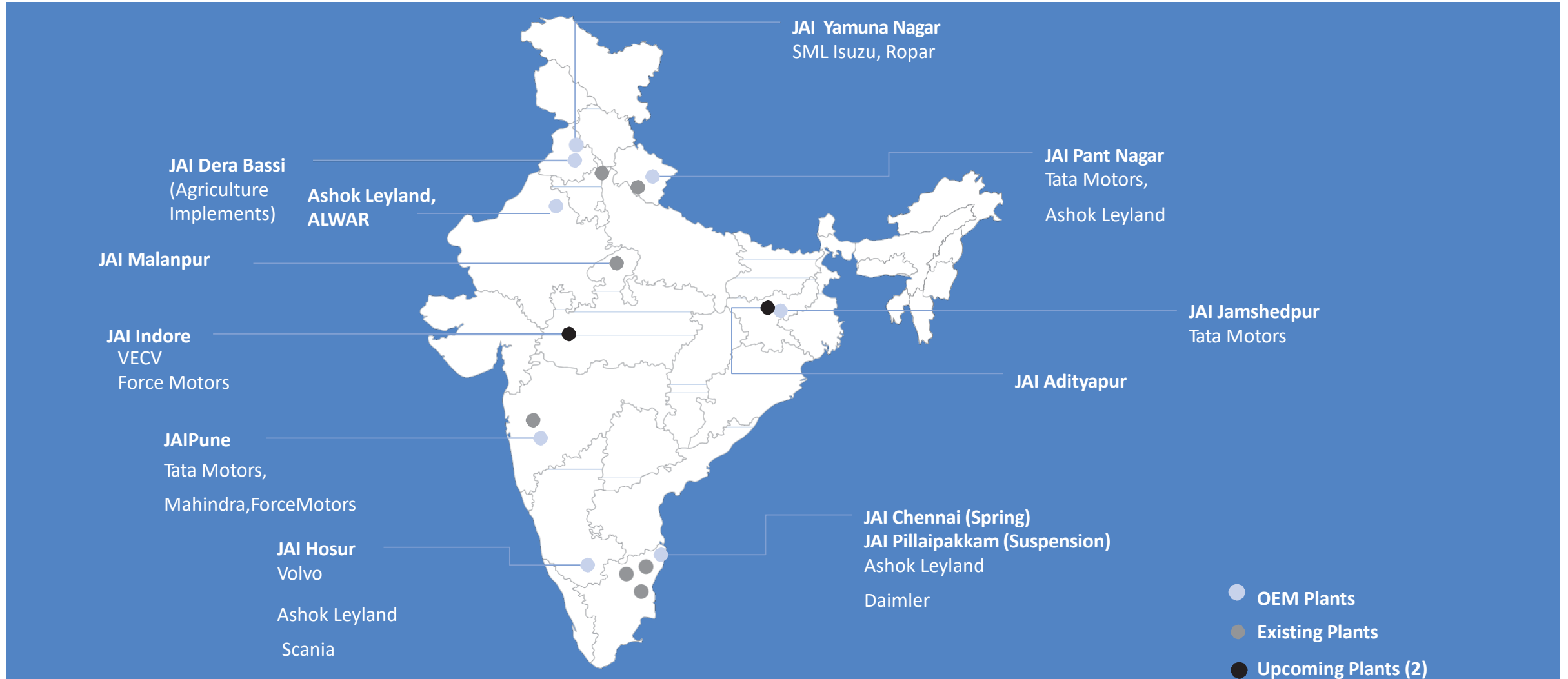

Note – Maps not to scale. All data, information, and maps are provided “as is” without warranty or any representation of accuracy, timeliness or

Strength and Key Focus Areas

Strength

- Manufacturing footprint with logistics benefit.
- Low BEP with Low Leveraged.
- Spare capacity to capture unprecedented demand from all Markets.
- Wide After Market Network
300+ Distributors,
11500+Retailers,
15000+ Mechanics.



Key Focus Areas

- New Markets (AMI, AME).
- New Products (Trailer, CPV in CV).

JAI's OEM Customers



JAI's Product Portfolio

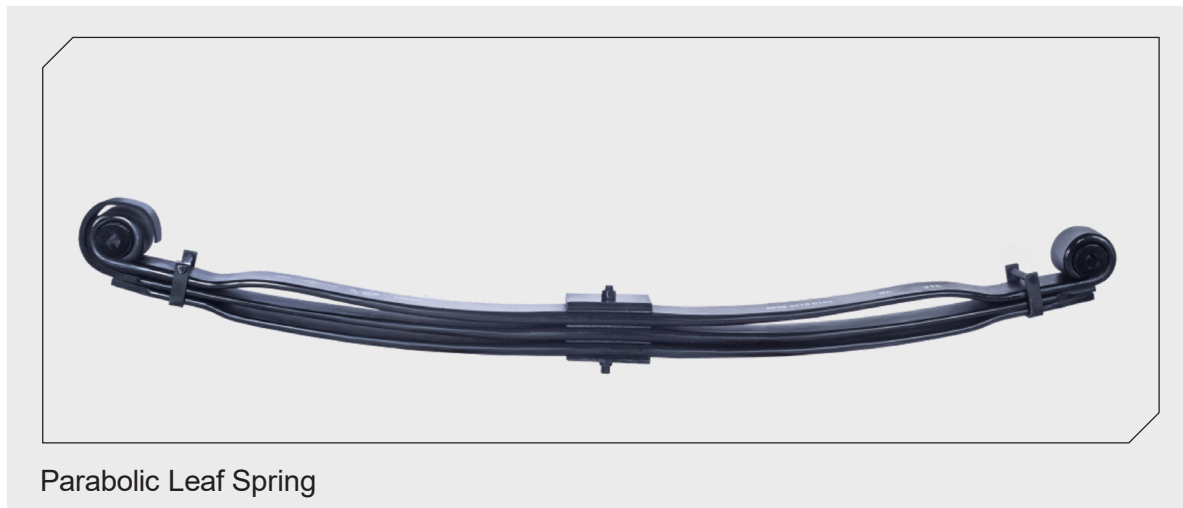
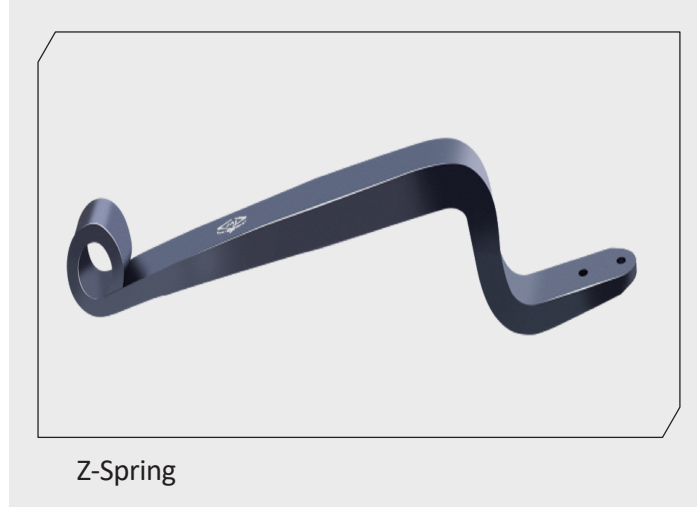

JAI's Product Portfolio

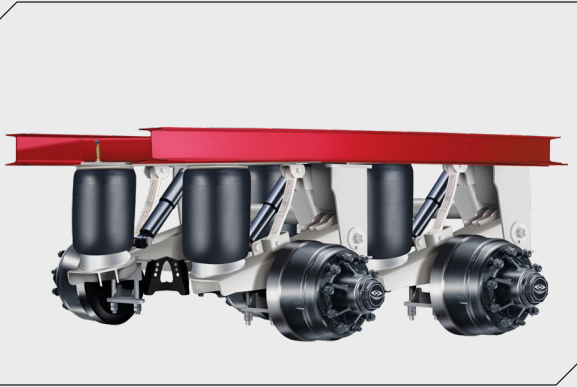

Bus Air Suspension

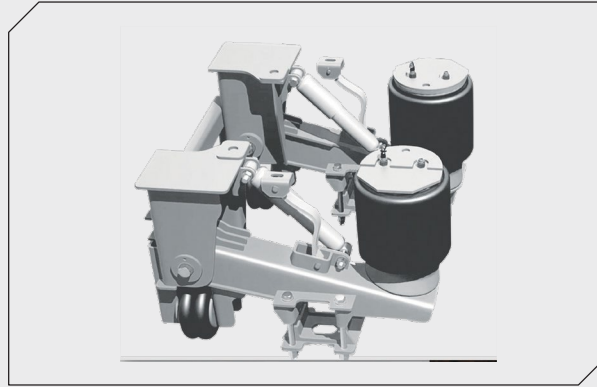

Trailer Air Suspension



Lift Axle

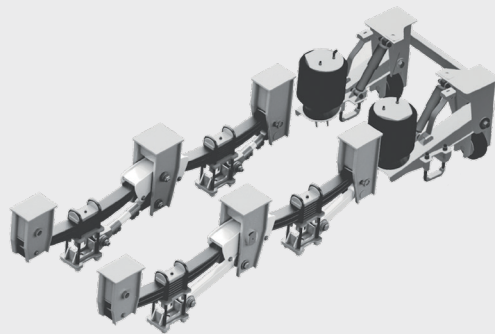

Trailer Mechanical and Air Suspension with Lift Axle

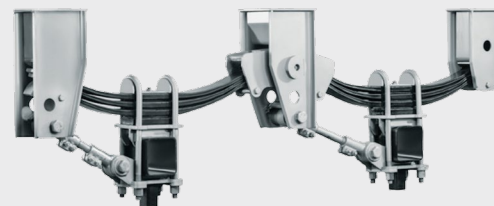

Trailer Mechanical Suspension

JAI's Product Portfolio



Agriculture Implements



Fertilizer Broadcaster



Fertilizer Broadcaster



Laser Land Leveller



Rotavator

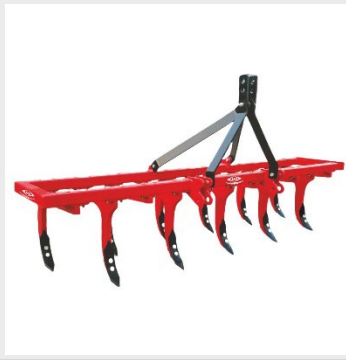

Cultivator

After Market India JAI's Product Portfolio

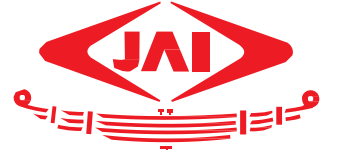

Lift Axle Allied Components

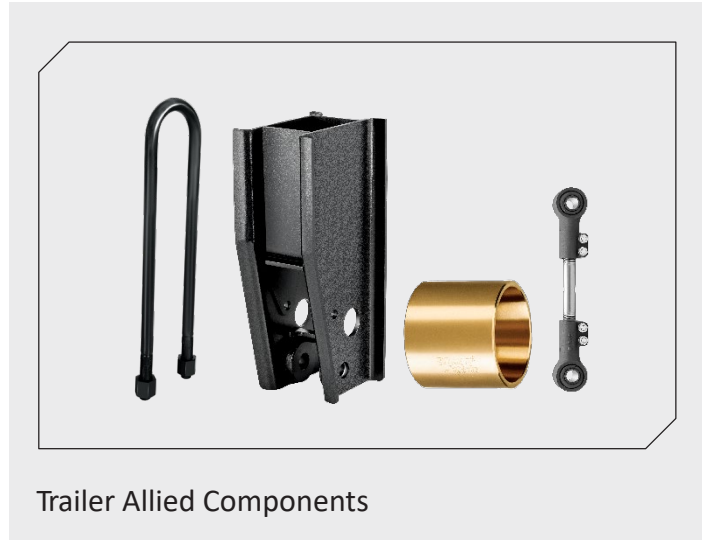

Trailer Allied Components

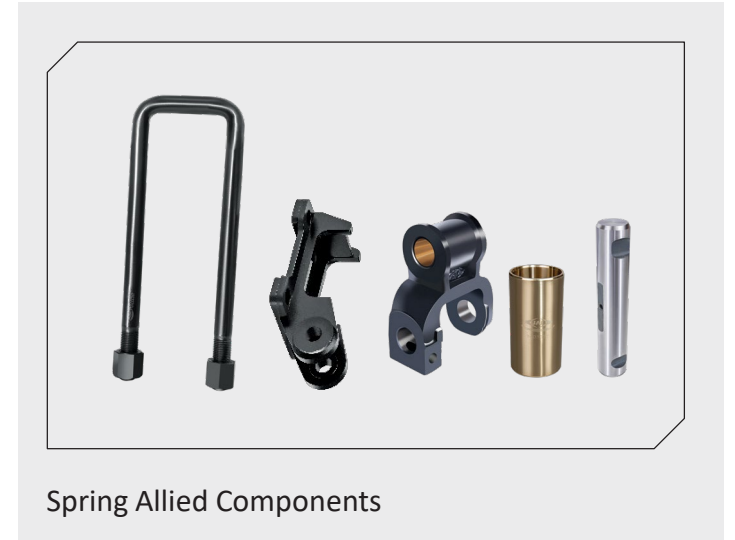

Spring Allied Components

After Market India JAI's Product Portfolio



Brake lining

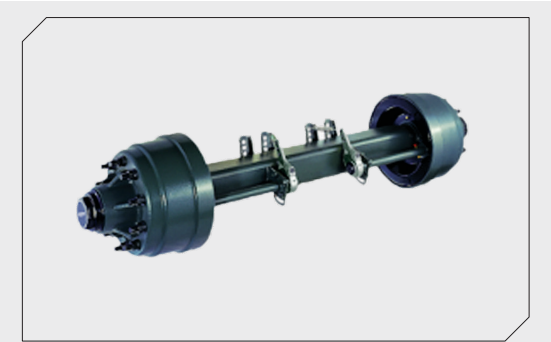

Trailer Axle



Water Pump



Clutch

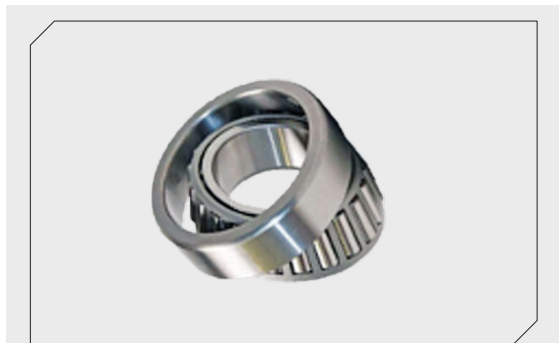

Bearing

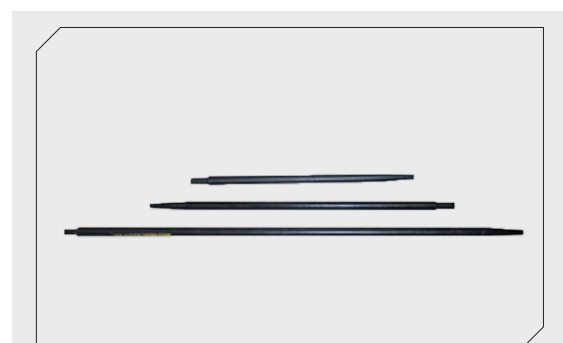

Jack Rod

Most of the products above are only traded

Jamna Auto Industries Limited ('JAI')

Shareholding Pattern as on 30th June 2024

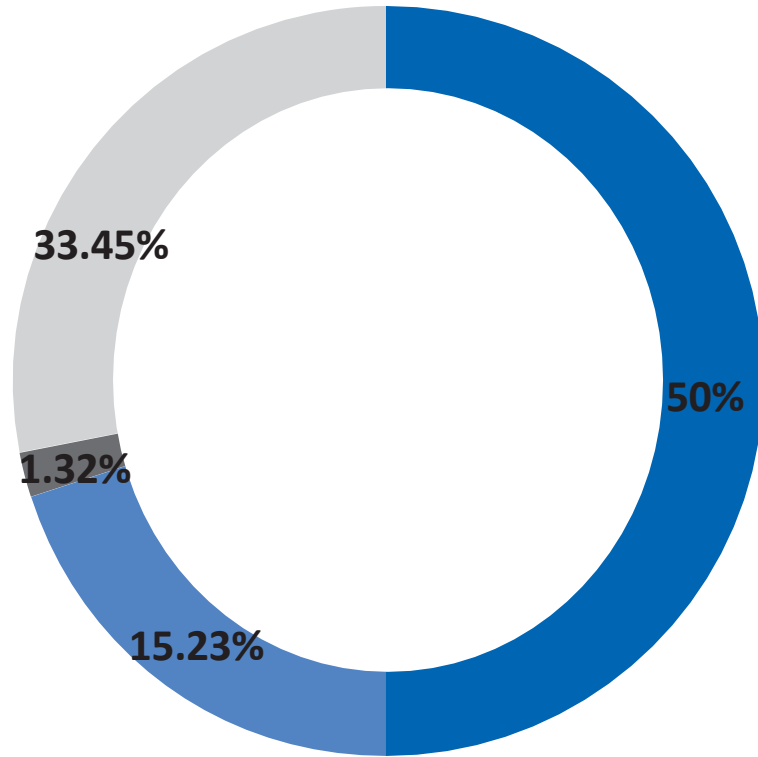

- Promoters
- Institutional investors

Categories	% Holding as on 30.6.2024	% Holding as on 31.3.2024
Promoters	50%	50%
Institutional Investors	15.23 %	14.81%
Bodies Corporate	1.32%	1.75%
Individual & Others	33.45%	33.44%
Total	100%	100%

Contributing to the Society



We are committed to contribute to the social and economic welfare of communities in which we operate. Playing an active role in sustaining positive change within society, we aim to create opportunities for the holistic development of people from all sections of society.

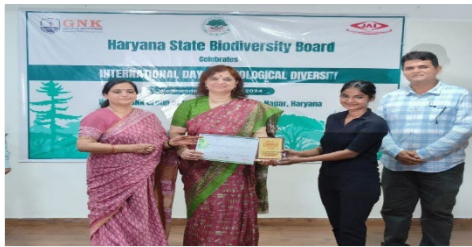

Celebrated International Day of Biological Diversity in GNK institute, YNR



DEO, YNR inaugurated drinking water station in Govt. school, Chandpur, YNR



Jai Sponsored swimmer set a National Record in XXIII-National Para Swimming Championship.



Conducted Eye check-up camp in Faizpur, YNR



Contributing to the Society



Environment

- Planted 200 saplings on the occasion of World Environment Day in Delhi, Yamuna Nagar, Malanpur & Pant Nagar.
- Celebrated World Earth Day by organising awareness activities like poster making rally and cleanliness drives.
- Distributed 2250 jute bags among beneficiaries to reduce plastic use in Delhi, Pillaipakkam, Delhi. YNR & Pune .
- Celebrated International Day of Biological Diversity, by awarding organic farmers and creating awareness lectures by Chief Conservator of Forests and DFO, Yamuna Nagar.
- Produced 500 kg vermin-compost in YNR & Jamshedpur.



Education

- Installed 04 water coolers in adopted Govt. schools in Yamuna Nagar.
- Gifted 05 computers to public library in Police line, YNR.
- Total 39 female were trained in advance stitching and tailoring course in Yamuna Nagar.
- Set-up a new Sewing Training Centre for 55 female trainees in Gandhi Nagar, Yamuna Nagar



Sports

- Sponsored monthly diet to 15 sportspersons in YNR, Mohali and Jamshedpur.
- 25 children under training in Jamna Archery Academy, Jamshedpur.
- Celebrated World Yoga Day in skill training and NFE centers to mark health and fitness.
- Our Sponsored swimmer Tejas N. set a National Record in the XXIII-National Para Swimming Championship.

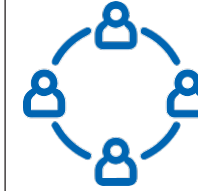

Community Reach

- More than 5000 people sensitized on occasion of World No Tobacco day by creating awareness sessions by experts, film shows, oral screening camps etc. at various locations.
- 220 nutrition kits were distributed to anemic girls & pregnant women in Yamuna Nagar & Chennai.
- Screened 121 people in eye check-up camp and distributed medicines & 100 spectacles to the needy patients in Yamuna Nagar.
- Served food to more than 500 migrant labor and orphan children every month in YNR.
- Financially supported to 04 BPL families for daughters marriage.
- Distributed monthly pension to 119 sr. citizens, widow and PwD's in Yamuna Nagar.





Thank You
