

November 22, 2021

**BSE Limited  
Department of Corporate Services  
P. J. Towers, 25th Floor, Dalal Street,  
Mumbai- 400 001  
Ref: 532509**

**National Stock Exchange of India Ltd  
Exchange Plaza, C-1, Block-G,  
Bandra Kurla Complex, Bandra (E)  
Mumbai- 400 051  
Ref: SUPRAJIT**

Dear Sirs,

**Sub: Investor Presentation**

Please find enclosed Investors' Presentation and Presentation on Suprajit Technology Centre, which may be presented to various investors, analysts while meeting and also while attending investor conferences, if any, from time to time. These presentations are also available in our website at [www.suprajit.com](http://www.suprajit.com).

This is for your Information and records.

This may be considered as compliance under Regulation 30 of SEBI (Listing Obligations and Disclosure Requirements) Regulations, 2015.

Thanking you,

Yours faithfully,  
**For Suprajit Engineering Limited**



**Medappa Gowda J  
CFO & Company Secretary**



Encl: as above

The slide features a blue background with a pattern of thin, parallel lines in the top-left corner and a hexagonal pattern in the bottom-left corner. A dark blue arrow-shaped banner points to the right, containing the main title. Below the banner is a red horizontal bar with the date. The rest of the slide is white.

# Suprajit Technology Centre Investor Presentation

Date: 22 November 2021

# Agenda

-  New Products
-  Investor Information



# Electronics



## Platform 1.0

Farm Equipment

Electric Vehicles

ICE 2W



## Platform 2.0

Outdoor Power Sport

Electric Vehicles

ICE 2W



## Platform 3.0

Electric Vehicles

ICE 2W



## Rotary Sensor

Farm Equipment

Outdoor Power Sport

Construction



## Electronic Grip

Electric Vehicles

ICE 2W



# Allied Products

PATENTED

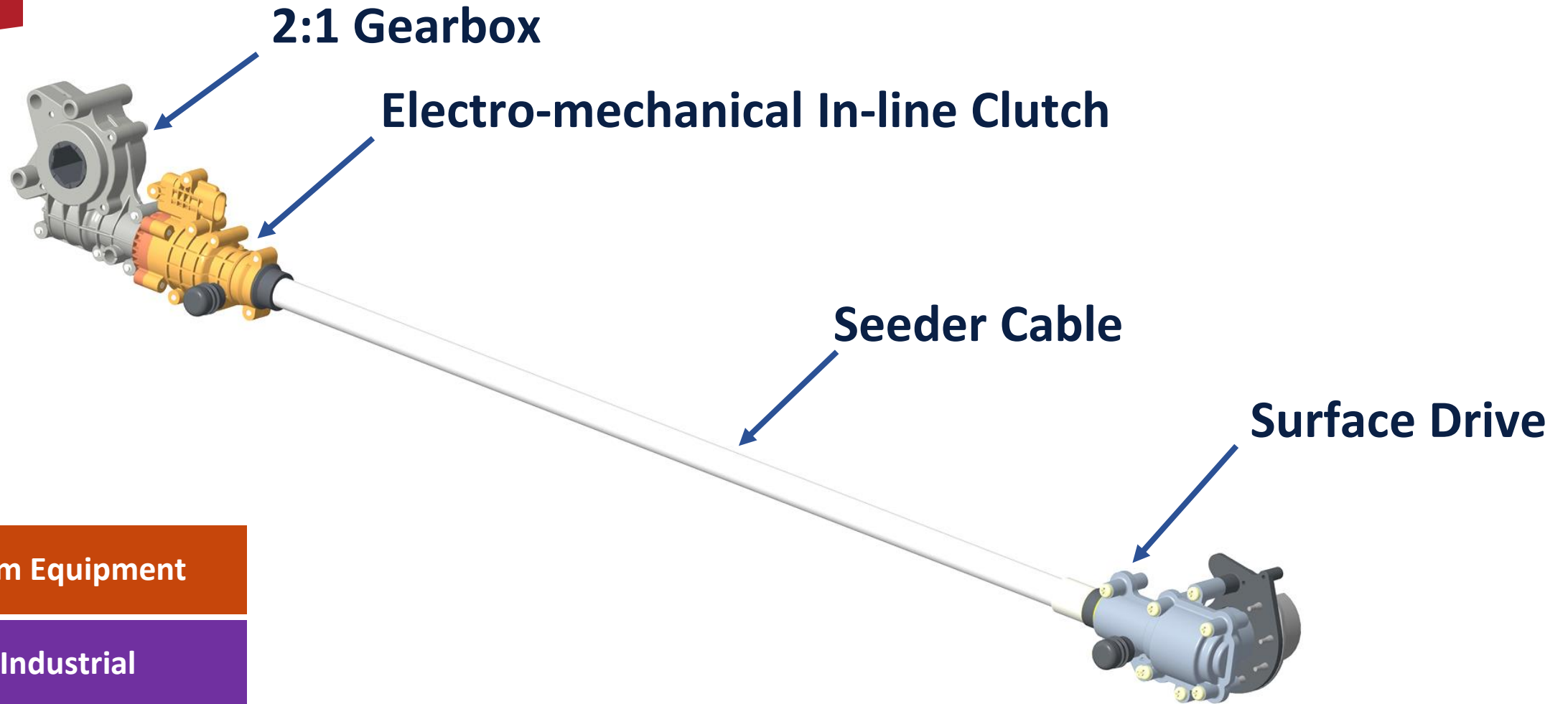

Farm Equipment

Industrial



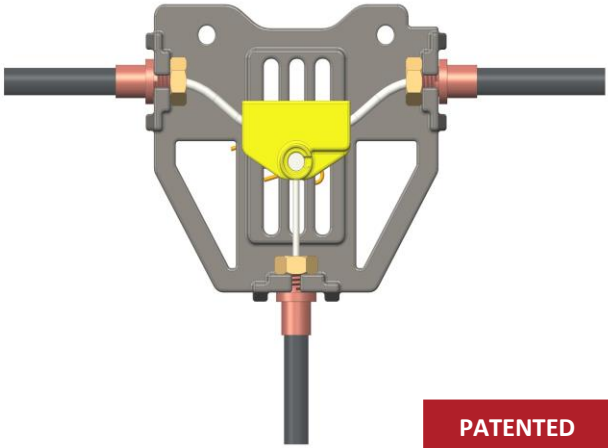

PATENTED

## CBS (Scooters)

Electric Vehicles

ICE 2W

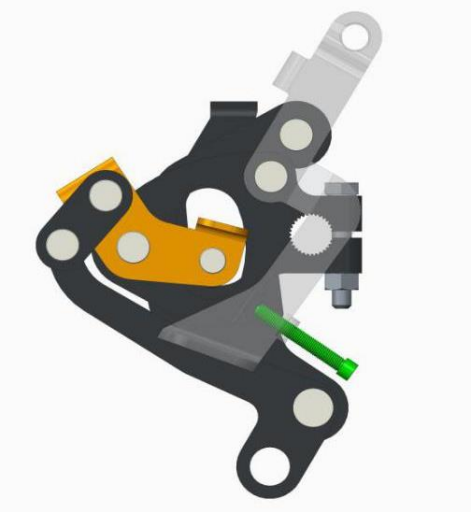

## CBS (Motorcycles)

ICE 2W

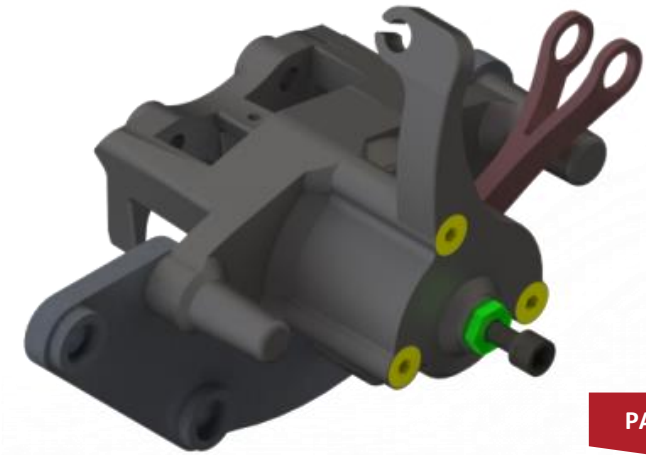

PATENTED

## Brake Actuation

Electric Vehicles

ICE 2W

Outdoor Power Sport

Turf Equipment

\* CBS – Combined Braking System

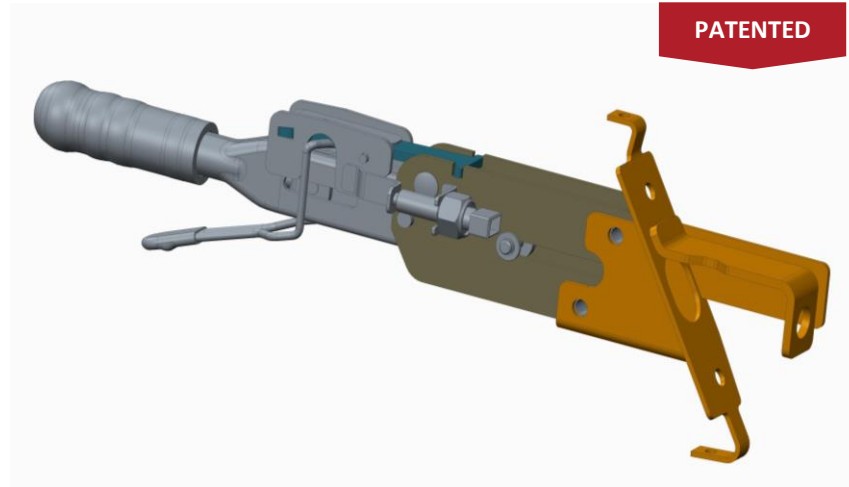

## Toggle Hand Brake

Construction

Industrial



## Parking Brake Release

Industrial



# Investor Information

- The new Technology Centre (STC) is fully integrated, with the ability to take an idea from concept all the way through to first batch production under one roof.
- The ultimate goal is for STC to rapidly conceptualise, design, prototype, test and validate new products that become the next cornerstone product line of the company.
- Initial businesses won and orders expected on the aforementioned products, and others, are in excess of Rs. 100 crores/year on an annualised basis.
- Further businesses are being negotiated with various customers.
- STC is expected to have significant impact on future growth plans of the Company.
- Suprajit will be in a unique position as an extremely lean and frugal manufacturing outfit that is complimented by a highly effective new product design capability, executing the complete cycle for the customer from concept to commercialisation.



Thank You