



Jamna Auto Industries Ltd.

November 14, 2019

To,
BSE Limited
Phiroze Jeejeebhoy Towers, Dalal Street,
Mumbai- 400001 Maharashtra

BSE Code: 520051

To,
National Stock Exchange of India Limited
Exchange Plaza, Plot no. C/1, G Block,
Bandra-Kurla Complex, Bandra (E)
Mumbai - 400 051, Maharashtra

NSE Code: JAMNAAUTO

Subject–Presentation on the financial results for second quarter of Financial Year 2019-20

Dear Sir,

Pursuant to the requirements of Regulation 30 and Regulation 46 of SEBI (Listing Obligations & Disclosure Requirements) Regulations, 2015, we are enclosing herewith the presentation by the Company pertaining to the financial results for second quarter of Financial Year 2019-20.

Kindly take the above information on record.

Thanking you,

Yours faithfully,

For Jamna Auto Industries Limited

Praveen Lakhera

Company Secretary & Head-Legal





Encl: As above



Jamna Auto Industries Ltd.

Investors' Presentation
Q2 FY'20

Company Overview

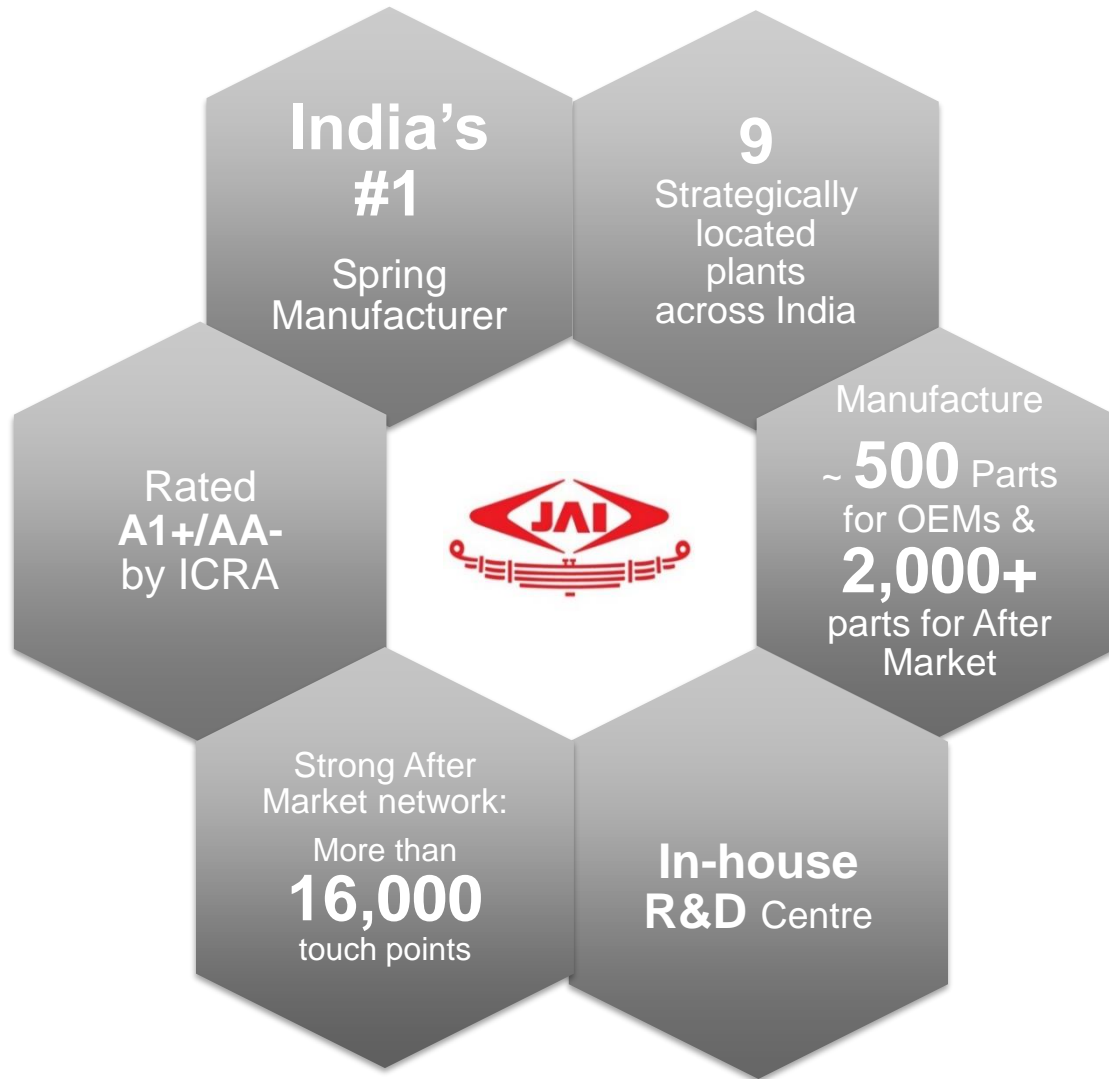

Jamna Auto Industries Limited is referred to as "JAI" hereafter

Expand Locations

Manufacturing Plants

- Yamuna Nagar
- Malanpur
- Chennai 1- Leaf Spring
- Chennai 2- Suspension
- Jamshedpur
- Pune
- Hosur

Assembly Plants

- Lucknow*
- Pant Nagar*

New Locations

- Indore
- Adityapur*

*Under subsidiaries of Jamna

Diversify Products

Existing Products

- Leaf Spring
- Parabolic Spring
- Lift Axle
- Air Suspension

Products in the pipeline

- Stabilizer Bar
- U Bolt
- Z Springs
- Trailer Suspension

De-risk Markets

Existing Markets

- OE India
- AM India
- AM Exports
- OE Exports

Key Strengths

Team of expert, innovative, self driven people

Best in class manufacturing facilities

Largest Supplier to Tata, Leyland & Daimler

Prudent financial management policies

Operational Goals

Financial Goals

Product De-risking

Diversifying Markets

Maximizing Returns

Value Creation

GOALS

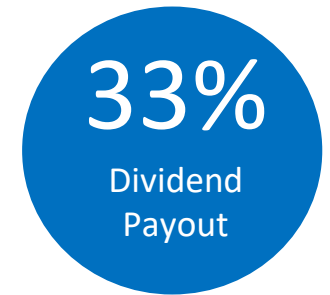
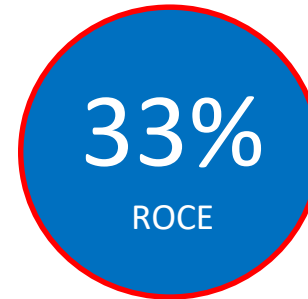

ACHIEVED
FY'19

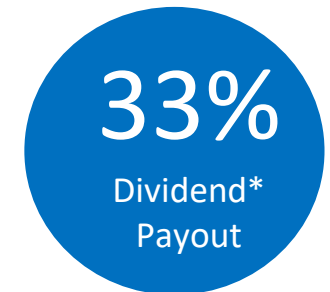
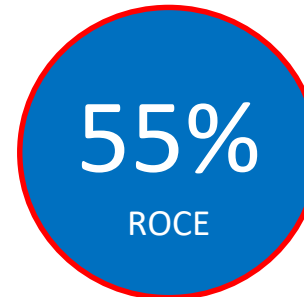

**9th consecutive year of dividend payout*

JAI's OEM Customers



Existing Products

Conventional Leaf Spring



Parabolic Leaf Spring



Lift Axle

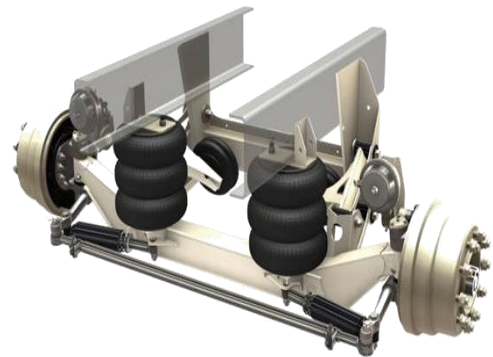

Air Suspension

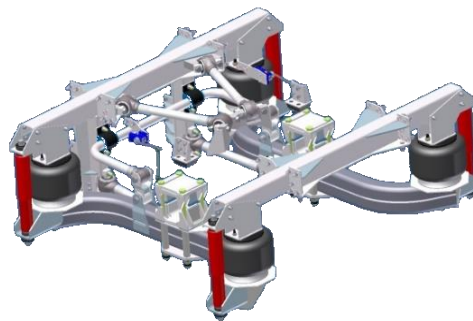

Upcoming Products

Stabilizer Bar



U Bolt



Z Spring



Trailer Suspension

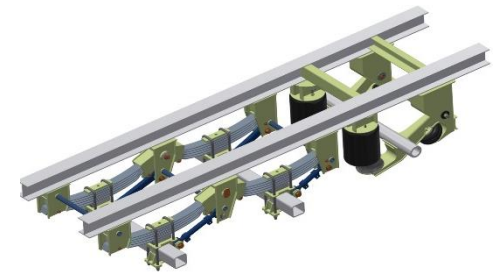

JAI's Plants: Strategically located across CV hubs

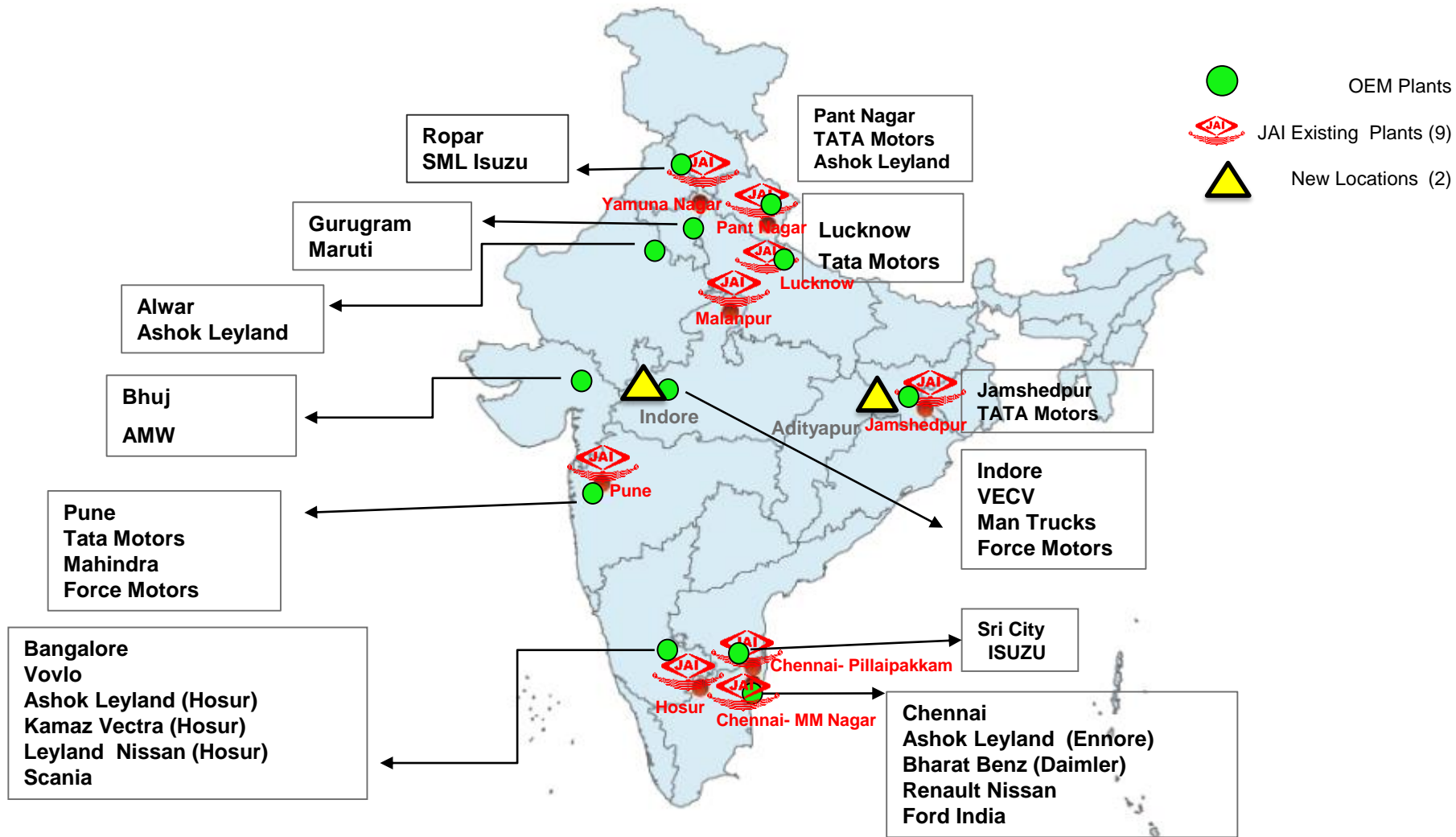

Map Source: as available on www.surveyofindia.gov.in dated 17.02.2017
The Map is for illustrative purpose only

Category Wise Breakup

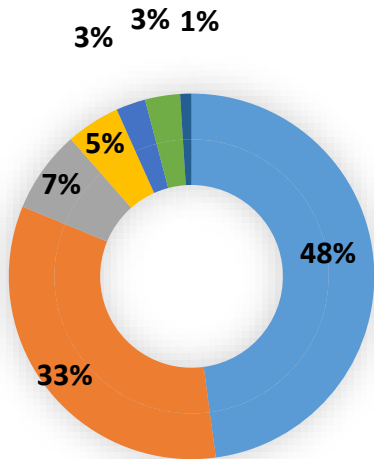

- Promoters
- Individuals
- Mutual Funds
- Foreign Portfolio Investors
- Bodies Corporate
- Financial Institution & Others
- NRIs

Categories	% Holding
Promoters	48%
Individuals	33%
Mutual Funds	7%
Foreign Portfolio Investors	5%
Bodies Corporate	3%
Financial Institution & Others	3%
NRIs	1%
Total	100%

Industry Highlights

- Global economic activity has weakened further, according to World Economic Outlook Update, October 2019.
- According to RBI's Monetary Policy Report (October 2019), India's GDP growth is projected at 6.1% in 2019-20, 5.3% in Q2; with a slight improvement in Q3 and Q4 at 6.6% and 7.2% respectively.
- CV Sector impacted by demand slowdown because of weak sentiment in Indian industry, liquidity stress, inventory liquidation by OEMs due to BS VI.
- M&HCV production declined by 56% YoY in Q2'20.

Decline in the CV Industry

- Total CV production declined by 39% YoY
- M&HCV production saw a decline of 56% YoY

Indian CV Production: Q2'20 vs Q2'19

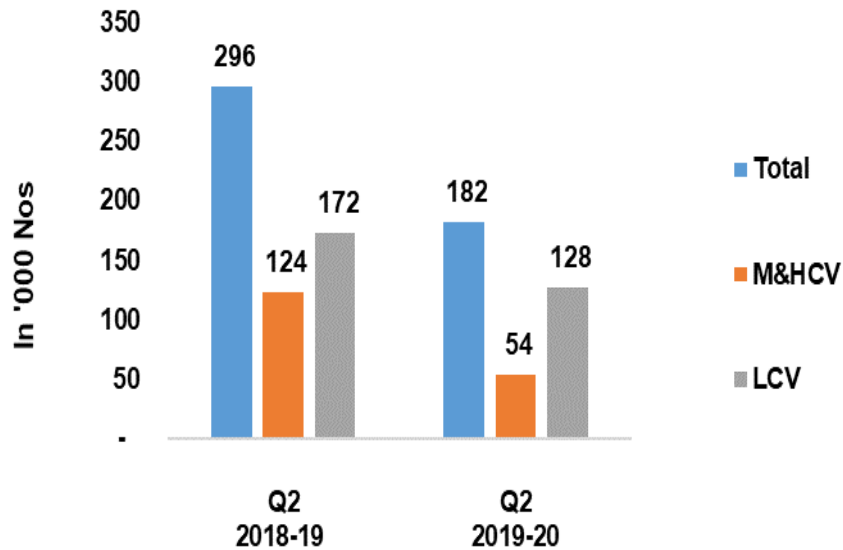

Data Source- SIAM + Internal

JAI's market share at 69% for the quarter

Market Share - OEM India

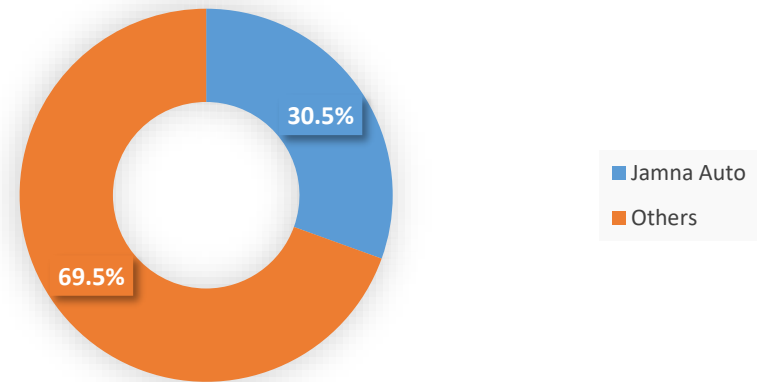

Data Source- Internal

1980's

Leaf Spring Manufacturer	Base Country	Capacity
NHK Spring Co. Ltd	Japan	200,000
Delphi	USA	100,000
Eaton/Oxford	Canada	100,000
Krupp	Germany	40,000
Hendrickson	USA	40,000
DSP	USA	40,000
Rejna	Europe	40,000
Hoesh	Germany	30,000
Sarfedern	Germany	20,000
Johns Woodhead	UK	10,000

JAI has come as the top spring manufacturer of the world for CV Industry

Current

Leaf Spring Manufacturer	Base Country	Capacity
Rassini	Mexico	250,000
Jamna Auto Industries Limited	India	250,000
Hendrickson	Canada & Mexico	216,000
NHK Spring Co. Ltd	Japan & Thailand	150,000
Dong Feng	China	105,000
FAW	China	100,000
MBHA	Spain	60,000
Olgen	Turkey	40,000
LPDN	Europe	26,500

Capacity in Tons per Annum

Financial Updates

Key Financial Trend : Q2 FY'20 Vs. Q2 FY'19



All Figures in Rupees Crore

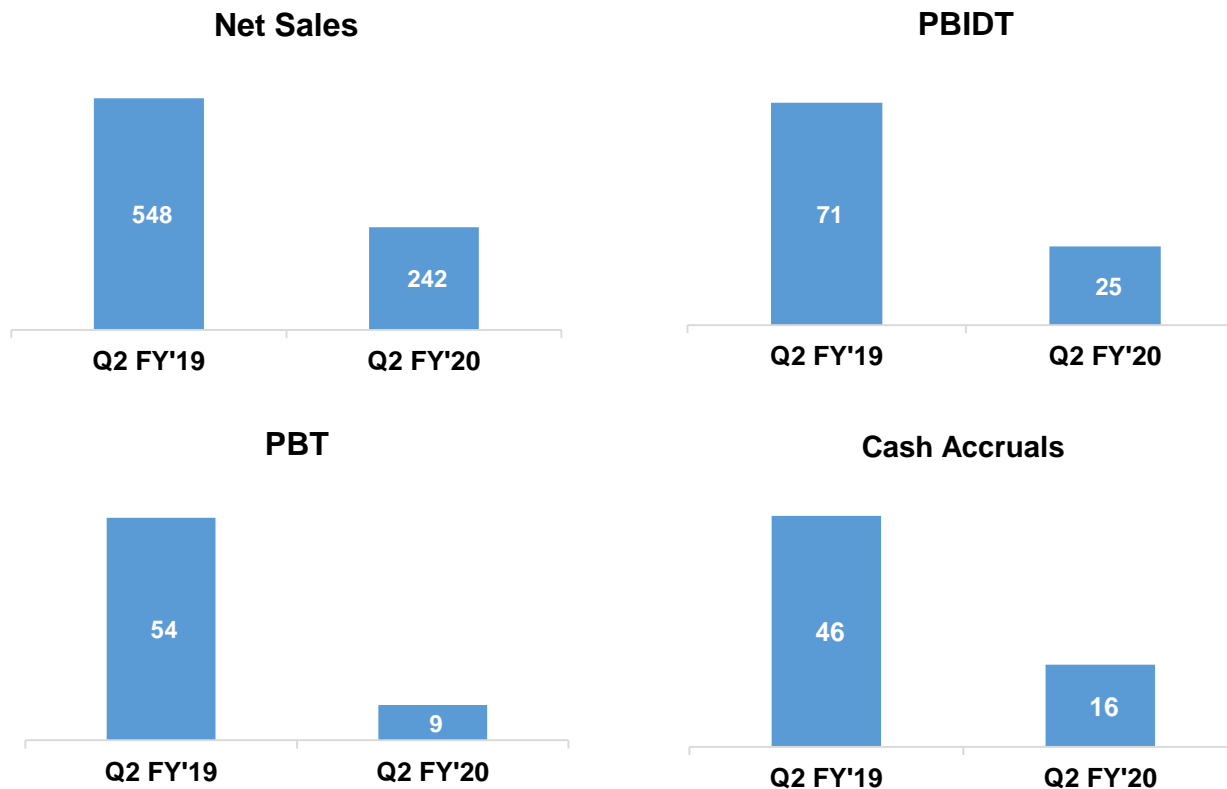

The drop in business is largely driven by lower Commercial Vehicle demand in this quarter.

Cash Accruals: PAT+ Depreciation

Financial Result – Q2 FY'20



All Figures in Rupees Crore

Revenue and Profitability Indicators`						
Particulars	2018-19	2019-20	2018-19	2019-20	% Growth	% Growth
	12M	Q2	Q2	Q1	Q2 FY'20 Vs Q2 FY'19	Q2 FY'20 Vs Q1 FY'20
Net Sales	2,135	242	548	421	-56%	-42%
PBIDT	287	25	71	47	-65%	-47%
Operating Margin	241	15	61	34	-75%	-55%
PBT	215	9	54	30	-84%	-71%
PAT	137	6	36	20	-82%	-69%
Cash Accruals	184	16	46	34	-64%	-51%
PBDITA Margin (%)	13%	10%	13%	11%		
Operating Margin (%)	11%	6%	11%	8%		
PBT (%)	10%	4%	10%	7%		
PAT (%)	6%	3%	6%	5%		
Cash Accruals (%)	9%	7%	8%	8%		

Cash Accruals: PAT+ Depreciation

Key Capital indicators		
Particulars	Q2'20	Q1'20
TOL/TNW	0.7	1.0
Debt to Equity	0.1	0.1
Average Cost of Borrowing	8.4%	8.5%

CSR Achievements in Q2 FY'20:

Environment: Planted & gifted 17,760 saplings/seeds in all JAI locations.

Education: Improved basic facilities like construction of drinking water tank, toilets, floor, multipurpose hall, installation of water coolers, furniture, electrical etc. in adopted schools and colleges in Yamuna Nagar, Gurugram, Faridabad, Malanpur, Jamshedpur, Chennai & Kapurthala.

Sports: Pradeep Kumar, our sponsored wrestler from Jalandhar, Punjab won Gold medal in World Police Games-2019, held in China.

Community Service : 1049 community people were screened for oral and breast cancer while more than 3000 were sensitized about the same issue in collaboration with Yuvraj Singh Foundation in Delhi, Gurugram, Jamshedpur and Malanpur.



Distribution of saplings to Govt. school students in Malanpur, MP



Installation of water coolers in government school



Pradeep Kumar Punjab won Gold medal in World Police Games-2019



Cancer Screening at Delhi Office.

Forward Looking Statement

This presentation is made to enable investors to comprehend our prospects and take informed investment decisions. This presentation may contain certain forward looking statements within the meaning of applicable laws and regulations. We cannot guarantee that these forward-looking statements will be realized, although we believe we have been prudent in assumptions. The achievement of results is subject to risks, uncertainties and even inaccurate assumptions. Should known or unknown risks or uncertainties materialize, or should underlying assumptions prove inaccurate, actual results could vary materially from those anticipated, estimated or projected. Readers should bear this in mind. We undertake no obligation to publicly update any forward-looking statements, whether as a result of new information, future events or otherwise.

Thank You