

July 27, 2021

To,  
National Stock Exchange of India Limited  
Symbol – SYMPHONY

To,  
BSE Limited  
Security Code - 517385

**Sub.: Investor Presentation – Updates**

Dear Sir,

This is in reference to the above-mentioned subject line; we are enclosing herewith updated Investor Presentation. The same is also available on the website of the Company.

Kindly consider this as due compliance of relevant provisions of SEBI (Listing Obligations and Disclosure Requirements) Regulations, 2015.

Kindly take this on your record and oblige.

Thanking you,

Yours Truly,  
**For Symphony Limited**

**Mayur Barvadiya**  
**Company Secretary**

*Encl.: as above.*

Email: [companysecretary@symphonylimited.com](mailto:companysecretary@symphonylimited.com)

A large, stylized white bird graphic, possibly a phoenix or a similar mythical creature, is positioned on the left side of the slide. It has large, curved wings and a tail with a jagged, flame-like edge. The bird is set against a green background that transitions from a lighter shade on the left to a darker shade on the right.

Earnings  
PRESENTATION

Q1FY22

# Disclaimer

## Safe Harbour Statement

This presentation contains forward-looking statements which may be identified by their use of words like “plans,” “expects,” “will,” “anticipates,” “believes,” “intends,” “projects,” “estimates” or other words of similar meaning. All statements that address expectations or projections about the future, including, but not limited to, statements about the strategy for growth, product development, market position, expenditures, and financial results, are forward-looking statements. Forward-looking statements are based on certain assumptions and expectations of future events. The companies referred to in this presentation cannot guarantee that these assumptions and expectations are accurate or will be realized. The actual results, performance or achievements, could thus differ materially from those projected in any such forward-looking statements. These companies assume no responsibility to publicly amend, modify or revise any forward looking statements, on the basis of any subsequent developments, information or events, or otherwise.

## Portfolio of Global Brands



**Master Cool**<sup>®</sup>  
by Symphony

**Arctic Circle**<sup>®</sup>  
by Symphony

**ki**

 **BONAIRE**<sup>®</sup>  
The leaders in heating and cooling

 **CELAIR**

 **AIRAZONA**



---

# Management Comments

---

# Management View on Performance & Outlook

## Actual Performance:

- FY21 and Q1FY22 performance were impacted on account of the Covid-19.
- A second wave of Covid-19 struck during 2021 summer; coupled with the extensive lockdown in the summer of 2020 – both, the peak season for air cooler customer sales.
- Until middle of April-21 very robust demand and sentiments. Complete focus on maximising production
- Most of the advertisement and sales expenses were incurred in April-21 considering high demand. Hence, impacted EBITDA margins.
- However, our exports and overseas subsidiaries were not much impacted.

# Management View on Performance & Outlook

## Outlook :

- Management is reasonably confident to achieve much better performance in FY22 vis-à-vis FY21 on account of:
  - ✓ Variety of initiatives already undertaken by the management
  - ✓ Estimated Sharp increase in exports
  - ✓ In Jun-21 gross margin is in line with FY21 despite huge increase in input & freight costs. The Management expects gross margin on domestic sales for FY22 will be back to normal margin of around 50%
  - ✓ Accelerated turnaround of Climate Technologies in Australia in FY22 despite until Dec-20 it has been below expectation



---

# New Launches – Symphony India

---



## New Launch

# DiET3<sup>D</sup>



### Pop-up Touchscreen

Easy-to-use touchscreen control panel that pops up



### 3D Cooling

3-side cooling pads for superior cooling experience

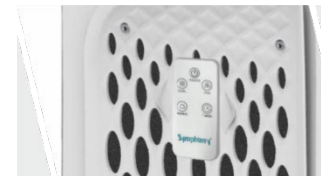

### Magnetic remote

Sticks on the cooler body

# New Launch

## New SUMO



'Easy-Fill' for hassle-free water filling



i-Pure console with multistage air purification filters



Specially designed +Air fan for more air

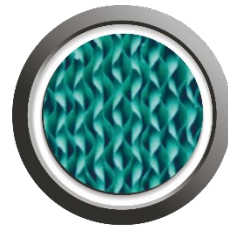

High efficiency honeycomb pads for superior cooling



New Launch

Hi Flo



Powerful air throw



Cool flow dispenser



High efficiency honeycomb  
for superior cooling



i-Pure technology



Large 27L water-tank cap

New Launch

**DUJET**  
Series

**Symphony**<sup>®</sup>

*Refreshing Lives*

**Symphony**<sup>®</sup>

*Refreshing Lives*



**Cooling Fan**  
from the house of Symphony

Available on **Flipkart** 

# New Launch

Symphony®

Refreshing Lives

## DUET<sub>i-s</sub> Cooling Fan Series

Currently available exclusively on e-commerce platforms, Symphony Duet is a personal cooling fan that boasts dual functionality of a fan and a cooler. It is available in two variants: Pedestal & Table.

- ✓ Detachable pedestal for dual usage - on the table or floor-standing
- ✓ Touchscreen control
- ✓ Surround cooling with swing option
- ✓ Honeycomb cooling pads
- ✓ Easy to carry



## New Campaign

For Household air coolers

*Mann Thanda  
Tann Taaza Rahe*

### Objective:

To put across a view that cool air can bring new perspectives in people's lives.

**BL** Business Line

### Summer cool

Air cooler brand Symphony, too, has got into the summer spirit, launching its 'Mann Thanda Tann Taaza Rahe' campaign.

21-Mar-2021







---

# Industrial and Commercial air coolers

---



## Industrial and commercial air coolers (Latest launches)



Universal air cooler – top and bottom discharge in the same cooler

Four-side high efficiency honeycomb pads

Powerful air throw

Robust weather-resistant body

# Launched a range of accessories

For easy and quick installation of industrial air coolers



Mouthpiece

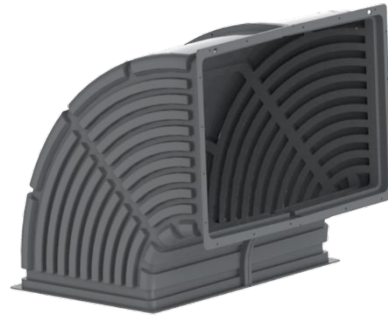

Elbow



Modular duct



Front grill with auto louvers



Variable Speed Controller



Controller for PAC20

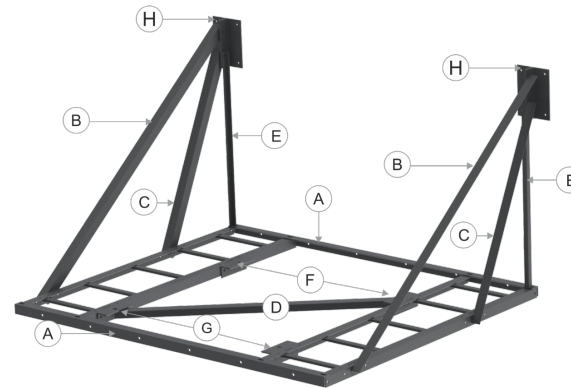

Wall mounting metal stand



Metal Trolley

# Industrial air cooling: New clients addition during Q1FY22

Working with esteemed brands

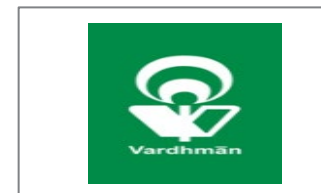

and many more...

# New Campaign

For Commercial air coolers (Movicool)

जब भी, जहां भी  
करना हो कूल  
सिम्फनी का  
मोविकूल

## Objective:

To create awareness about the Movicool range of air coolers & communicate its usage in various sorts of large spaces.



Afaqs

Symphony's latest spot aims to create awareness about new range of air coolers for large spaces

Indian multinational air-cooling company Symphony has launched a new campaign, titled 'Symphony ka Movicool', to introduce its new ...

29-Mar-2021



Brand Equity

Symphony launches new campaign for new range of air coolers

Symphony Ka Movicool jingle has been conceptualized to strike a chord with the audience. The simple yet catchy music was created after a lot of ...

25-Mar-2021





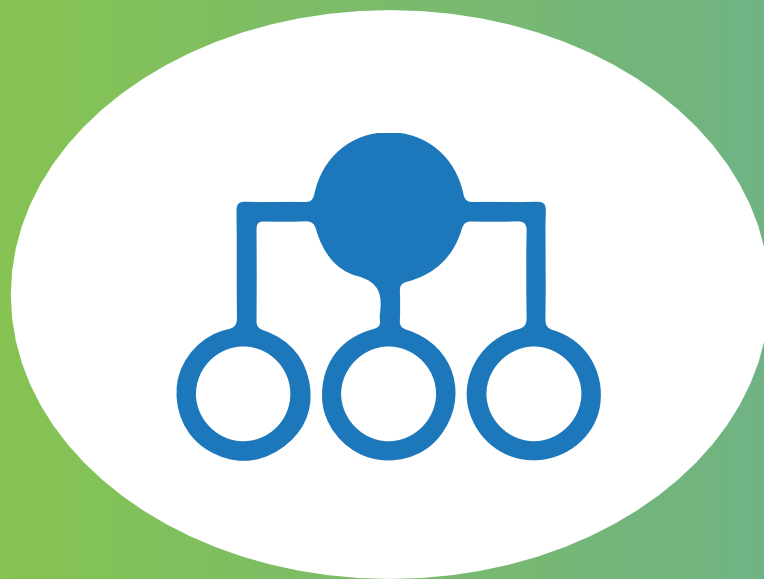

---

# New Launches - Subsidiaries

---

# New launches - Climate Technologies Pty. Ltd

## Australia: Roof mounted air coolers



### EAC

- ✓ 2 cabinet sizes, Reduce 10 SKUs of existing range.
- ✓ Low height, Sits snug on the roof.
- ✓ Installation compatible with all existing products.
- ✓ 3 different colours to match roof colours

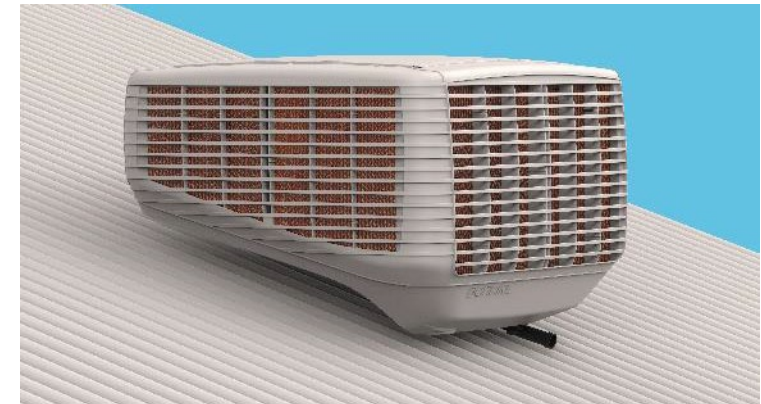

# New launches – Bonaire USA (BUSA)

## USA: Household air coolers



Duke

- ✓ All in one including, ventilation, humidification and purification.
- ✓ Full function remote with 7.5 hours timer
- ✓ Fully closeable horizontal louvers
- ✓ 3 wind speeds with auto vertical louver swing
- ✓ Two air delivery modes
- ✓ High Efficiency Cooling Pads
- ✓ Dust filters



# New launches - IMPCO, Mexico

## Window air coolers



### R28SW

- ✓ New Control Panel Design
- ✓ Rust free plastic side panels
- ✓ Float valve for uninterrupted cooling
- ✓ High efficiency cooling pads
- ✓ Auto Vertical Swing
- ✓ Fully closeable horizontal louvres

### R38W

- ✓ New Control Panel Design
- ✓ Rust free plastic side panels
- ✓ Float valve for uninterrupted cooling
- ✓ High efficiency cooling pads
- ✓ Auto Vertical Swing
- ✓ Fully closeable horizontal louvres

# New launches - IMPCO, Mexico

## HT Series air coolers



### SHT Movil

- ✓ Weatherproof engineering plastic
- ✓ High efficiency cooling pads
- ✓ Easy cleanable water tank
- ✓ Free installation kit
- ✓ Fully closable louvers

### SHT Movil XL

- ✓ Weatherproof engineering plastic
- ✓ High efficiency cooling pads
- ✓ Easy cleanable water tank
- ✓ Large water tank capacity
- ✓ Fully closable louvers

## New launches - GSK, China

### Household air coolers



#### CROWN i

- ✓ All in one including, ventilation, humidification and purification.
- ✓ 3-side high efficiency cooling pads
- ✓ Full function remote with 7.5-hour timer
- ✓ Removable Tank (Partial)
- ✓ Chill trays for enhanced cooling
- ✓ Dust filters



#### CROWN-M

- ✓ All in one including, ventilation, humidification and purification.
- ✓ 3-side high efficiency cooling pads
- ✓ Removable Tank (Partial)
- ✓ Chill trays for enhanced cooling
- ✓ Dust filters

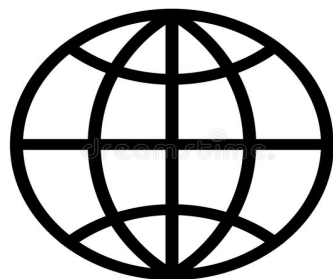

---

# D2C Brand Store

---

# Launch of Symphony D2C Brand store



With rising internet penetration in India and the ongoing digitalization of modern life, shopping through e-commerce platforms has seen exponential growth.

Leveraging this trend and with an aim to strengthen our digital presence, we launched a new website in India with e-commerce functionality.

Our customers now have a new channel to browse through our wide range of air coolers and purchase them from the convenience of their homes throughout the year!

# Launch of Symphony D2C Brand store

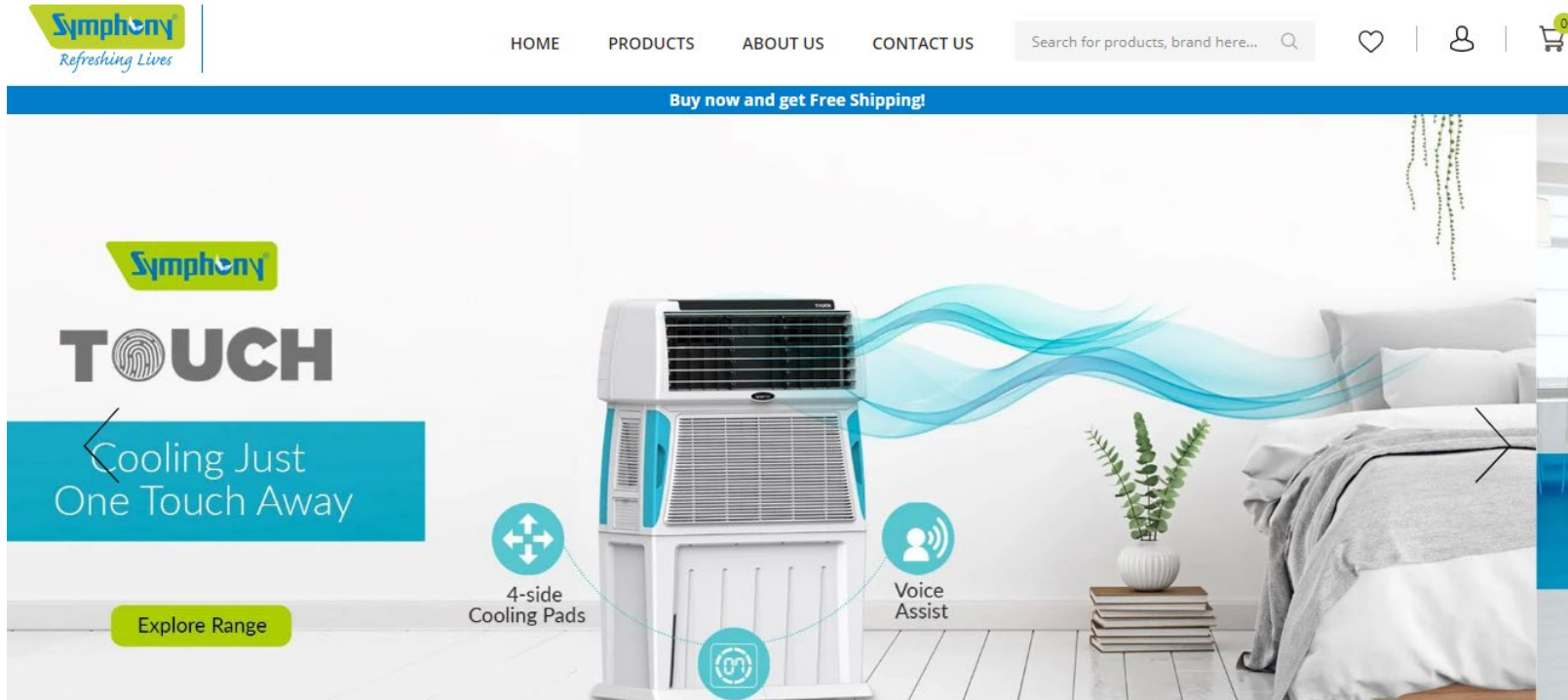

<https://www.symphonylimited.com/>

# Superior user experience and convenience

HOME PRODUCTS ABOUT US CONTACT US Search for products, brand here

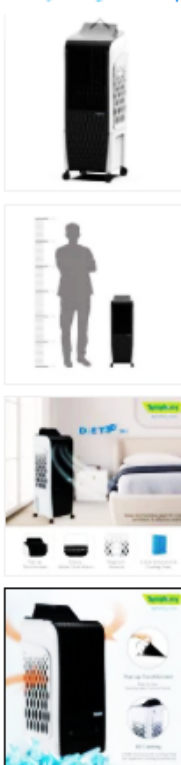

**Symphony**  
Refreshing Lives

**Pop-up TouchScreen**  
Easy to Use  
Touchscreen Control Panel

**3D Cooling**  
3-Side Honeycomb Cooling Pads  
for Superior Cooling Experience

### Symphony Diet 3D 20i Tower Air Cooler 20-litres with Magnetic Remote

In Stock Be the first to review this product

**Price** ₹7,991.00 ~~₹8,999.00~~ **11% OFF**  
You save ₹1,008.00 on this purchase

**Quick Overview**



- Large 20 L tank capacity
- For rooms up to 13 m<sup>2</sup>
- i-Pure technology
- High efficiency honeycomb pad
- Consumes 145 watts\* only
- Free Shipping

No Return Policy

**Quantity**

**Availability**

Compare

Share   



# Quarterly Financials



# Financials: Quarterly

**Consolidated (Rs Cr)**

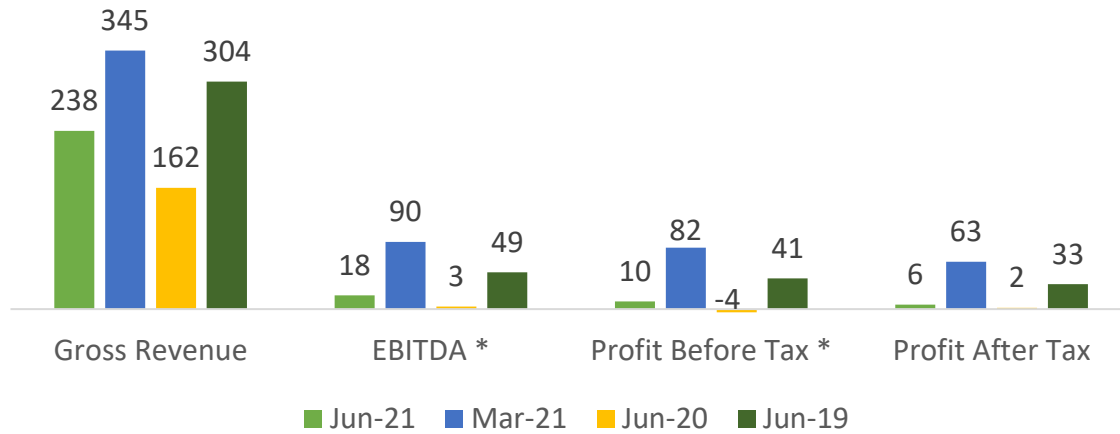

**Standalone (Rs Cr)**

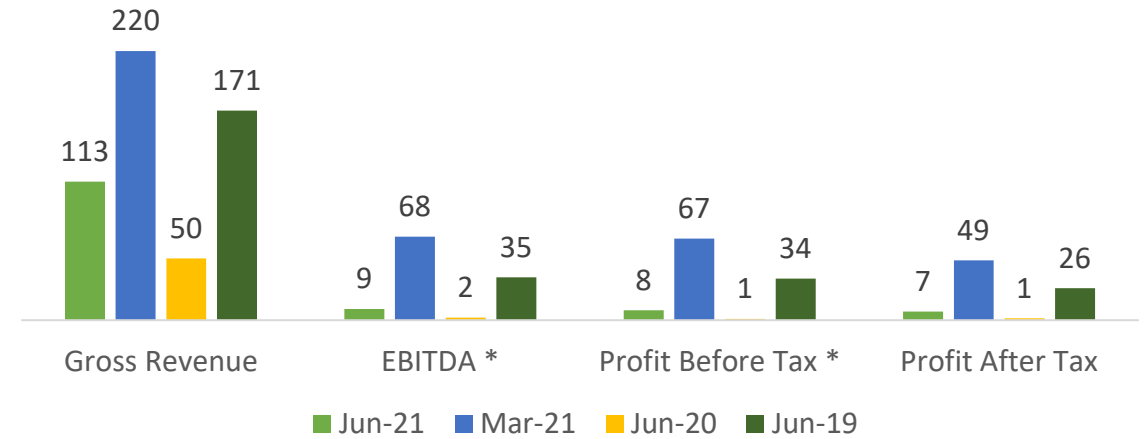

**Gross Margin (%)**

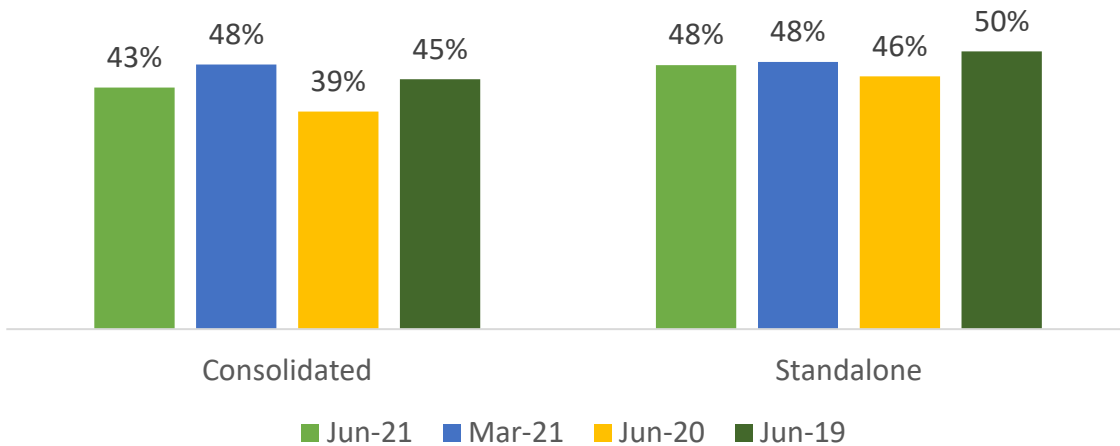

**EBITDA Margin (%)**

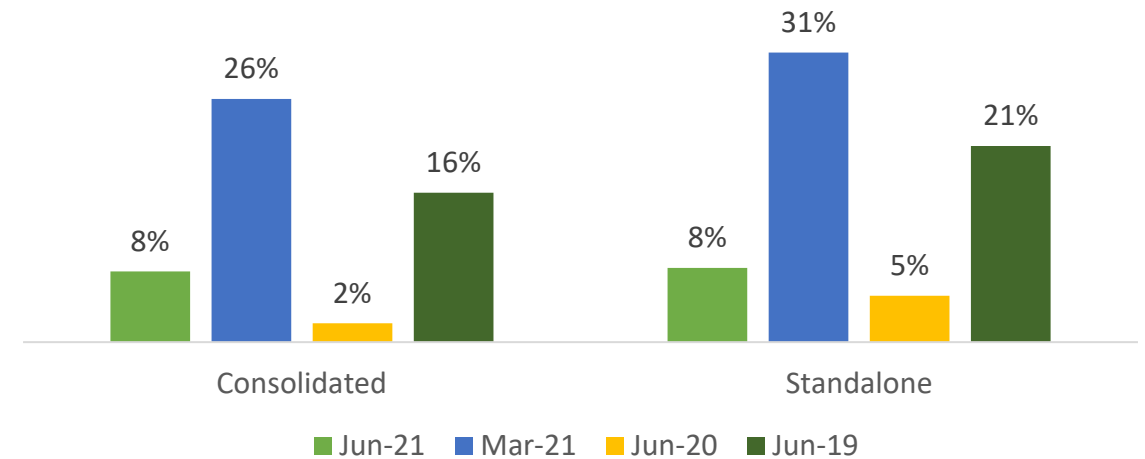

\*Excluding exceptional item. Gross Revenue include other income.

# Geographical break up of Sales

Revenue (Rs Cr)

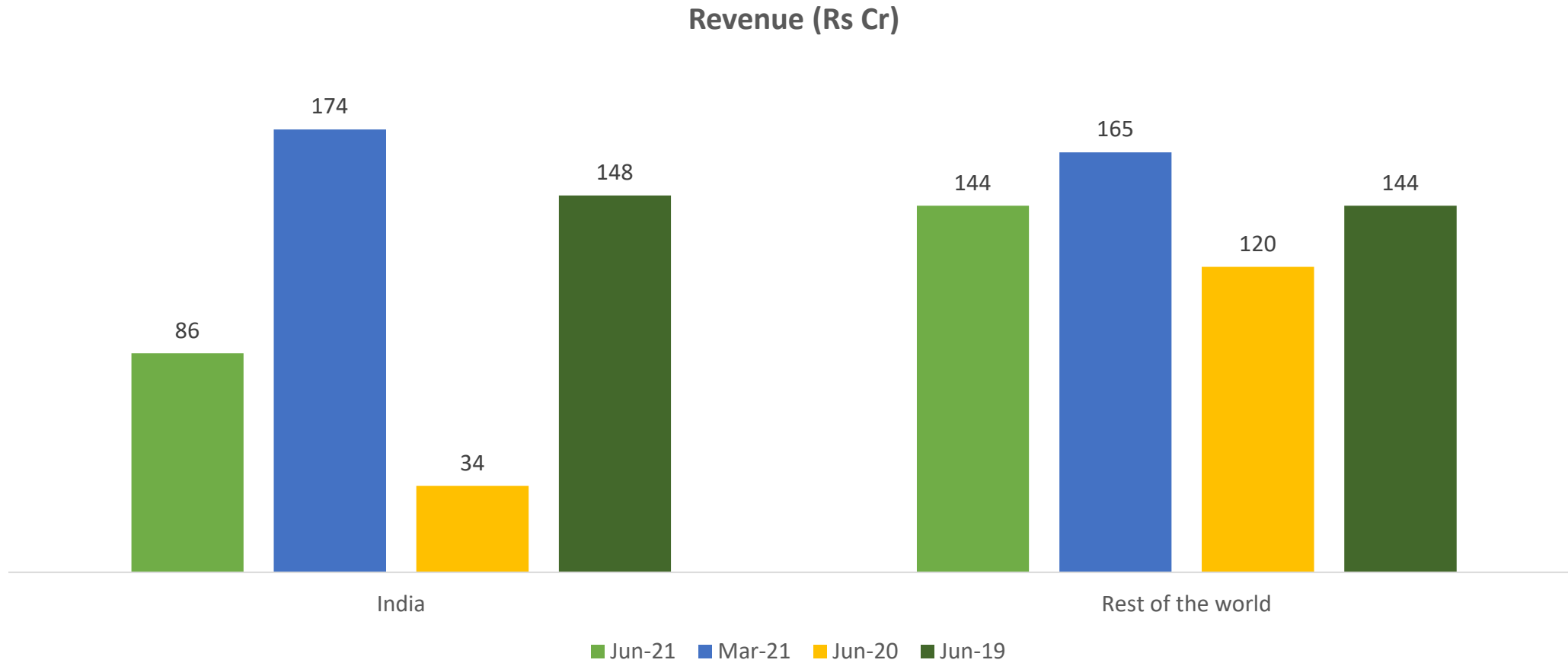

Note: June-2020 & June-2021 quarters have been impacted by lockdown due to COVID-19.

## Treasury (Rs. In Cr.)\*

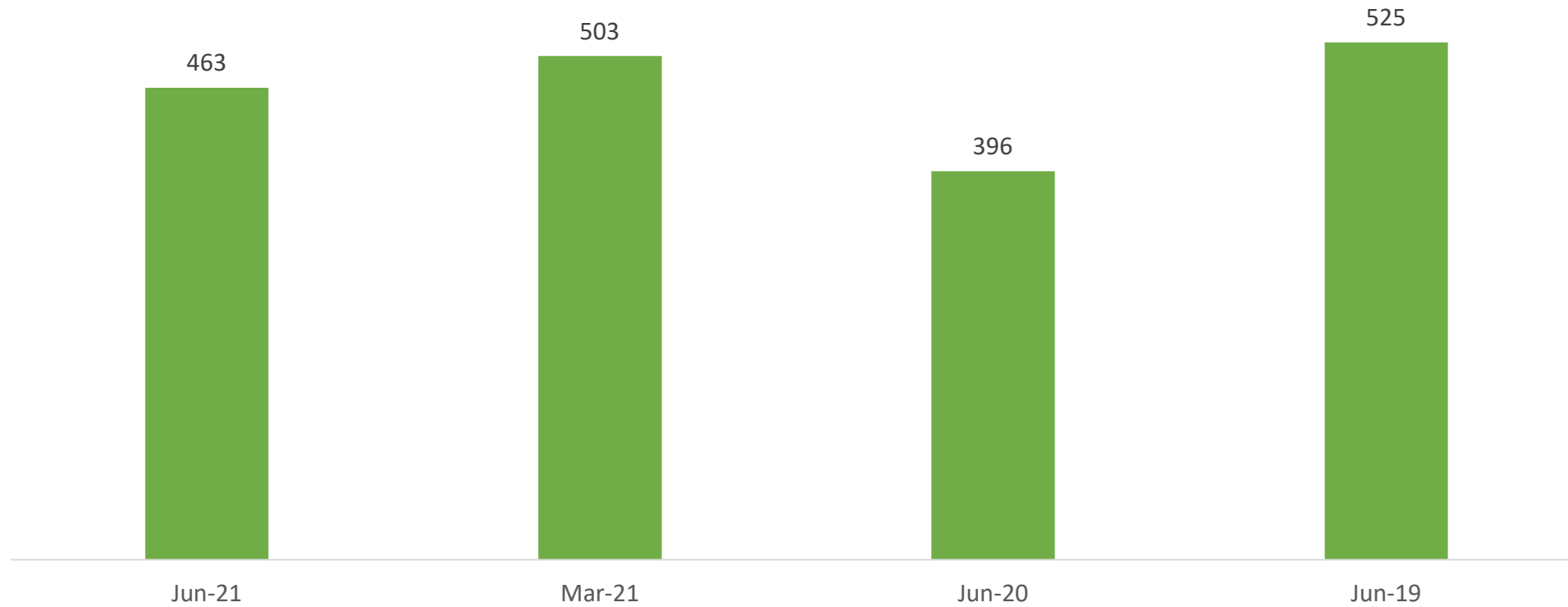

\* Excluding Equity Investments in and Loans to Subsidiaries.



*Refreshing Lives*

[www.symphonylimited.com](http://www.symphonylimited.com)

**MEXICO**

**Impco S de R L de C V**

AYAX 611, Parque  
Industrial Kalos  
Guadalupe, Guadalupe  
N L, Mexico 67205

**CHINA**

**Guangdong Symphony  
Keruilai Air Coolers Co. Ltd.**

Taiying Industrial Area,  
Hongmei Town, 523160  
Dongguan,  
Guangdong, China

**AUSTRALIA**

**Climate Technologies  
Pty. Ltd.**

26 Nylex Avenue  
Salisbury South SA  
5106  
Australia

**USA**

**Bonaire USA LLC**

3774, West Cheyenne  
Avenue, North Las Vegas,  
Nevada, 89032, USA

**INDIA**

**Symphony Limited**

Symphony House, FP12-TP50 Bodakdev, off SG Highway,  
Ahmedabad 380059

**Contact**

Phone: +91-79-66211111

Email: [investor@symphonylimited.com](mailto:investor@symphonylimited.com)