

GTPL Hathway Limited

CIN : L64204GJ2006PLC048908

Registered Office : 202, 2nd Floor, Sahajanand Shopping Centre,
Opp. Swaminarayan Temple, Shahibaug, Ahmedabad-380004, Gujarat.
Phone : 079-25626470 Fax : 079-61400007



Ref. No.: GTPL/SE/2022

January 13, 2022

BSE Limited

Phiroze Jeejeebhoy Towers,
Dalal Street,
Mumbai 400 001

National Stock Exchange of India Limited

Exchange Plaza,
Plot No. C/1, G Block,
Bandra Kurla Complex, Bandra (East),
Mumbai - 400051

Scrip Code: **540602**

Trading Symbol: **GTPL**

Dear Sir/Madam,

Sub: Investor Presentation on the Standalone and Consolidated Unaudited Financial Results for the quarter and nine months ended December 31, 2021

Kindly find enclosed herewith a copy of Investor Presentation on the Standalone and Consolidated Unaudited Financial Results for the quarter and nine months ended December 31, 2021.

The same will also be available on the Company's website, 'www.gtpl.net'.

Thanking you.

Yours faithfully,

For GTPL Hathway Limited

Hardik Sanghvi
Company Secretary & Compliance Officer
FCS: 7247



GTPPL Hathway Limited

**Q3 & 9M FY22
RESULTS UPDATE**

JANUARY 2022

DISCUSSION SUMMARY

1 Company Overview & Strategy

3 - 16

2 Key KPIs

17 - 19

3 Consolidated Financials

20 - 26

4 Standalone Financials

27 - 32



Company Overview & Strategy

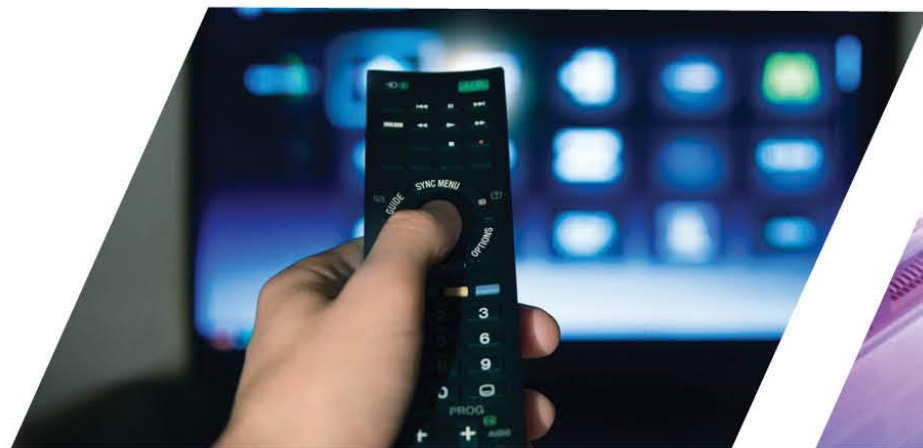



GTPPL

GTPPL is now the number 1 MSO in India*

*As per TRAI quarterly report

The central graphic features the GTPPL logo in large white letters on a blue background. The number '1' is highlighted in a 3D gold font. Below the logo, the text 'GTPPL is now the number 1 MSO in India*' is written in white. At the bottom right of the graphic, a small note reads '*As per TRAI quarterly report'. The background of the graphic is decorated with falling gold confetti.

Leader across Key Cable Markets in India

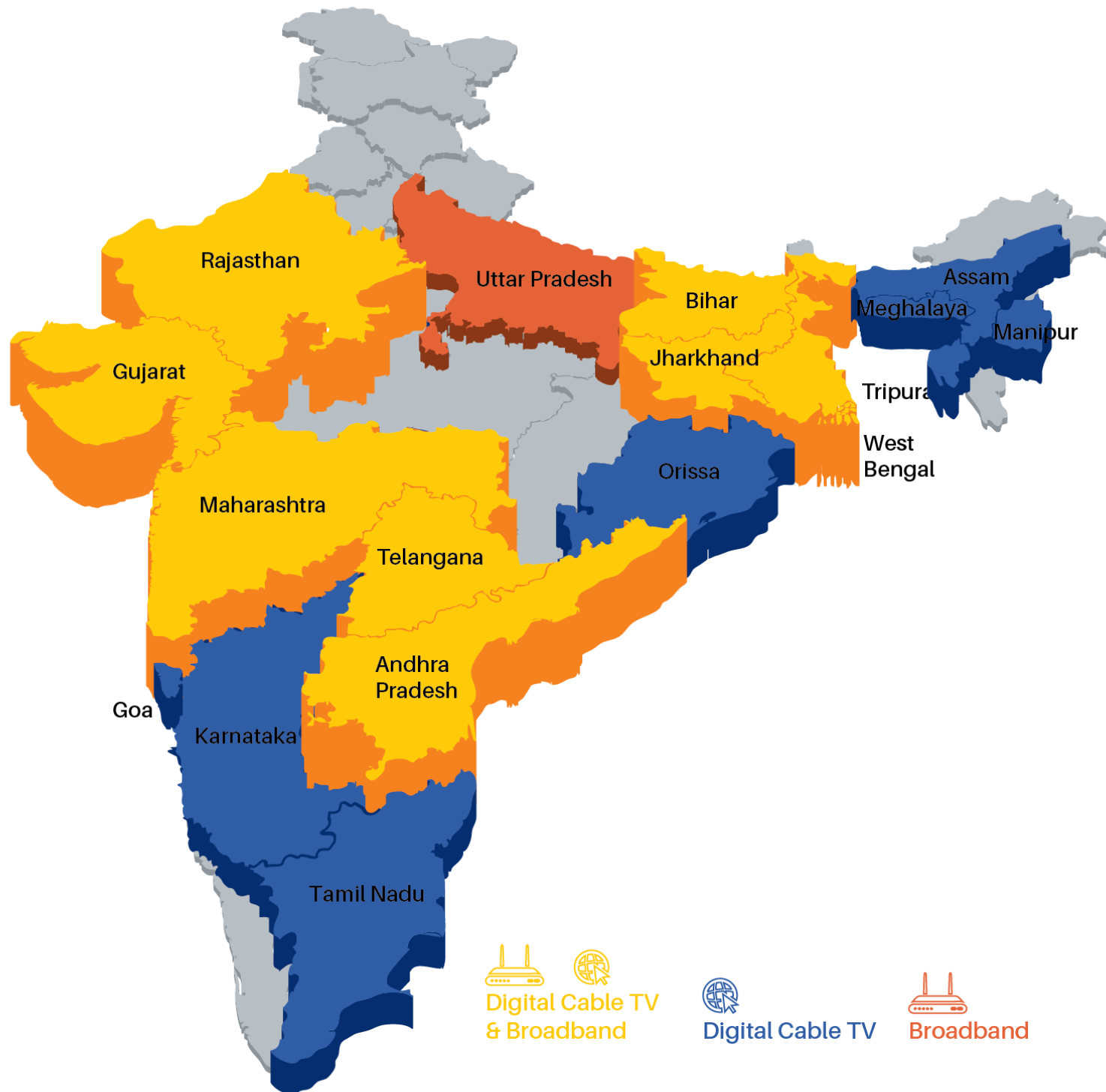

01 

Commenced Business in 2006

02 

Footprint in 1,100+ towns across 17 States reaching 10+ Mn Households

03 

#No.1* MSO in India
#No.1 MSO in Gujarat | #No.2 in WB

04 

#No. 6* Private Wireline Broadband Player in India
#No. 1 in Gujarat**

05 

Significant presence in Maharashtra, Andhra Pradesh, Telangana & Northeast

Sources :

* Performance Indicators Report, TRAI dated 10th Jan, 2022

** Independent third party Report





Subscriber Base

- **~1.7x** growth in last 5 years for CATV
- **~3.3x** growth in last 5 years for Broadband



Growth

- **~24%** CAGR growth in Revenue in last 3 years
- **~20%** CAGR growth in EBITDA in last 3 years



Consistent Performance

- **PAT Positive** for last Consecutive 5 years
- Upgraded to **“IND AA- /Stable”** by ‘India Ratings’



Cash Positive

- Free Cash Flow **(FCF)** generated for last consecutive 5 years



Dividend

- **Consistent** Dividend Paying History of last 5 years
- **40%** Dividend for FY21





Debt Reduction

- **“Net Debt Free”** company



Financial Performance : Consolidated*

Key Financial Highlights (in ₹ Mn)

	9M FY22		9M FY21		FY21	
	Incl. EPC.	Excl. EPC.	Incl. EPC.	Excl. EPC.	Incl. EPC.	Excl. EPC.
 REVENUE	18,288	17,945	17,423	15,493	25,300	21,484
 EBITDA	4,301	4,277	4,170	4,032	5,724	5,455
 PAT	1,454 [#]		1,314		1,885	

[#] Exceptional Items (Loss on Insurance Claim Receivables) of ₹ 124 Mn for 9M FY22

- ✓ Revenue Growth (Ex. EPC) of ₹ 2,451 Mn 9M-o-9M; Increase by 16%
- ✓ EBITDA Growth (Ex. EPC) of ₹ 245 Mn 9M-o-9M; Increase by 6%
- ✓ PAT Growth of ₹ 140 Mn 9M-o-9M; Increase by 11%



Business Performance

CATV



8.20 Mn
Active¹
Subscribers



7.50 Mn
Paying
Subscribers



80%+
Collection through
Digital Mode



100%
base in Prepaid
Business

**Extended
Footprint in
Karnataka
& Odisha**



30,000+
Business
Partners

Expanding in, Maharashtra, Andhra Pradesh, Telangana, Tamil Nadu & Northeast

Broadband



765K
Active
Subscribers
#130K increase in 9M



4.40 Mn
Home-
Pass
#530K increase in 9M



290K
FTTX
Subscribers



₹ 445/-
ARPU



5%
Q-o-Q ISP Revenue
growth



200 Mbps
Speed with
Unlimited Data

Expanding in Gujarat (Incl Rural Gujarat) directly & in Other States through Partners

¹Active = Active during last 60 days



GTPL in India's Top 500 Companies*



GTPL Hathway Ltd.
(Parent Company)

Recognized as one of
**"India's
Top 500 Companies"**



**GTPL Kolkata Cable
Broadband Pariseva Ltd.**
(Subsidiary Company)

Recognized as one of
**"India's Top 500
Mid-Corporates"**



**GTPL Broadband
Pvt. Ltd.**
(Wholly Owned Subsidiary)

Recognized as one of
**"India's
Top 500 SMEs"**

Key Inherent Strength of GTPL Hathway

Leadership Position in Operating Markets



- **#1 MSO in India,** #1 in Gujarat, #2 in West Bengal
- Significant Presence in Maharashtra; reaching ~1.5 Mn HH
- **#6 Private Wireline Broadband Player** #1 in Gujarat
- ~4.40 Mn Broadband Home-Pass

Located in Consumption Market



- Versatile Presence in Regional Markets
- Gujarat, Maharashtra, WB, South key markets for National and Regional Advertiser

Trusted Partner



- 30,000+ LCOs as Business Partners
- Bottom-up company – Transparency in its approach
- Ease-of-Business via multiple Apps in Vernacular Languages
- “Digital Payment Options” to LCOs & Subscribers

High Quality Technology and Infrastructure



- State-of-the-Art Next Generation Video Headend System from Harmonics Inc., USA
- High performance Exadata Database from Oracle
- State-of-the-Art BNG solutions from Nokia for high speed FTTX broadband



Cutting Edge Technology and Infrastructure

Advanced technology and equipment provided by leading technology vendors

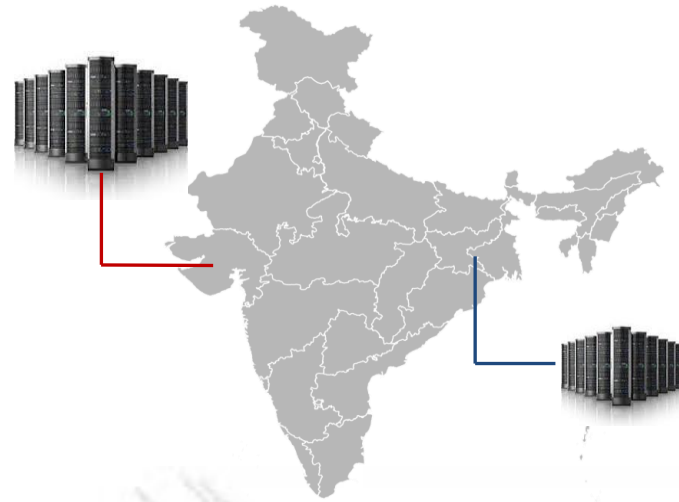

Headend:

- 2 Main Headend.
- Mother Headend & Network Operating Centre (NOC) in Ahmedabad (Gujarat), capable to cater across India.
- 2nd Main Headend in Kolkata (West Bengal).
- Distributing 750+ channels including 95+ HD channels across India.

Optic Fibre Cable Network:

- Owned : 50,000+ KMs
- Underground : 4,000+ KMs
- Leased: 6,500+ KMs

GPON Technology:

- Seamless connectivity
- Higher broadband speed
- VoD, OTT capabilities

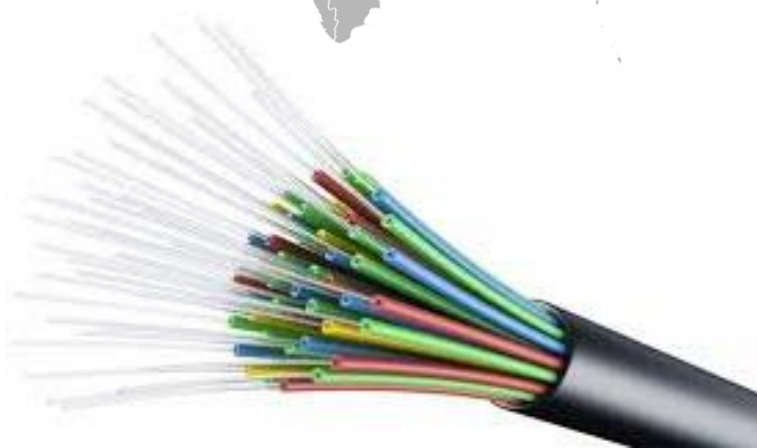

Technology Partners

Headend



STBs & Modems



SMS



CAS



Database



NOC & OSS



Experienced Management Team with Strong Track Record

Anirudhsinhji Jadeja
Promoter and MD

A zealous entrepreneur; started with cable operations in 90s and shaped GTPL in 2006; has many accomplishments to his credit and has won numerous industry/social awards

Anil Bothra
Chief Financial Officer

CA,CS and CMA with 26 years of experience; has worked with Grasim, Atul Ltd, Shell Hazira LNG etc. across various roles including Business Strategy, Corporate Finance, Budgeting, Internal Control and M&A

Piyush Pankaj
Business Head - CATV & Chief
Strategy Officer

CFA & MBA with 23 years of varied experience in Media, Internet & e-commerce; has worked in Astro Group (Malaysia) and Zee Group (India)

Neeraj Agrawal
Head Broadband (Retail)

MBA from Devi Ahilya Vishwavidyalaya University; 25 years of experience in managing diverse telecom products (both GSM & CDMA), largely in Reliance Communications

Subrata Bhattacharya
Chief Information & Technology
Officer

Electrical Engineer with 27 years of rich experience in analog / digital cable TV / Broadband Technology across reputed companies like RPG Netcom, Siti Cable & Cablecomm

V Guruprasad
Chief Technology Officer

Master in Electronics, having 30 years of experience in Broadband and Cable Technology enterprises like Reliance JIO, Silicon Applications(Singapore) and Scientific Atlanta

Ekta Kanade
Chief Legal Officer

Bachelor in Law, University of Bombay; 20 years of experience, largely in Media industry and organizations including Viacom 18, Walt Disney, etc.

Amit Shethia
Chief CSD Officer

BE (Mechanical) from MSU, Baroda; has worked in Bharti Airtel, Idea Cellular and Reliance Communication; 28 years experience in Sales & Customer Service Delivery domains

Ashish Srivastava
Chief Human Resource Officer

Masters in Personnel Management from Poona University; 27+ years' experience in leading HR operations across reputed companies like M & B Engineering Ltd, Larsen & Toubro, Vodafone Idea Ltd, and Gujarat Ambuja Cements Ltd.



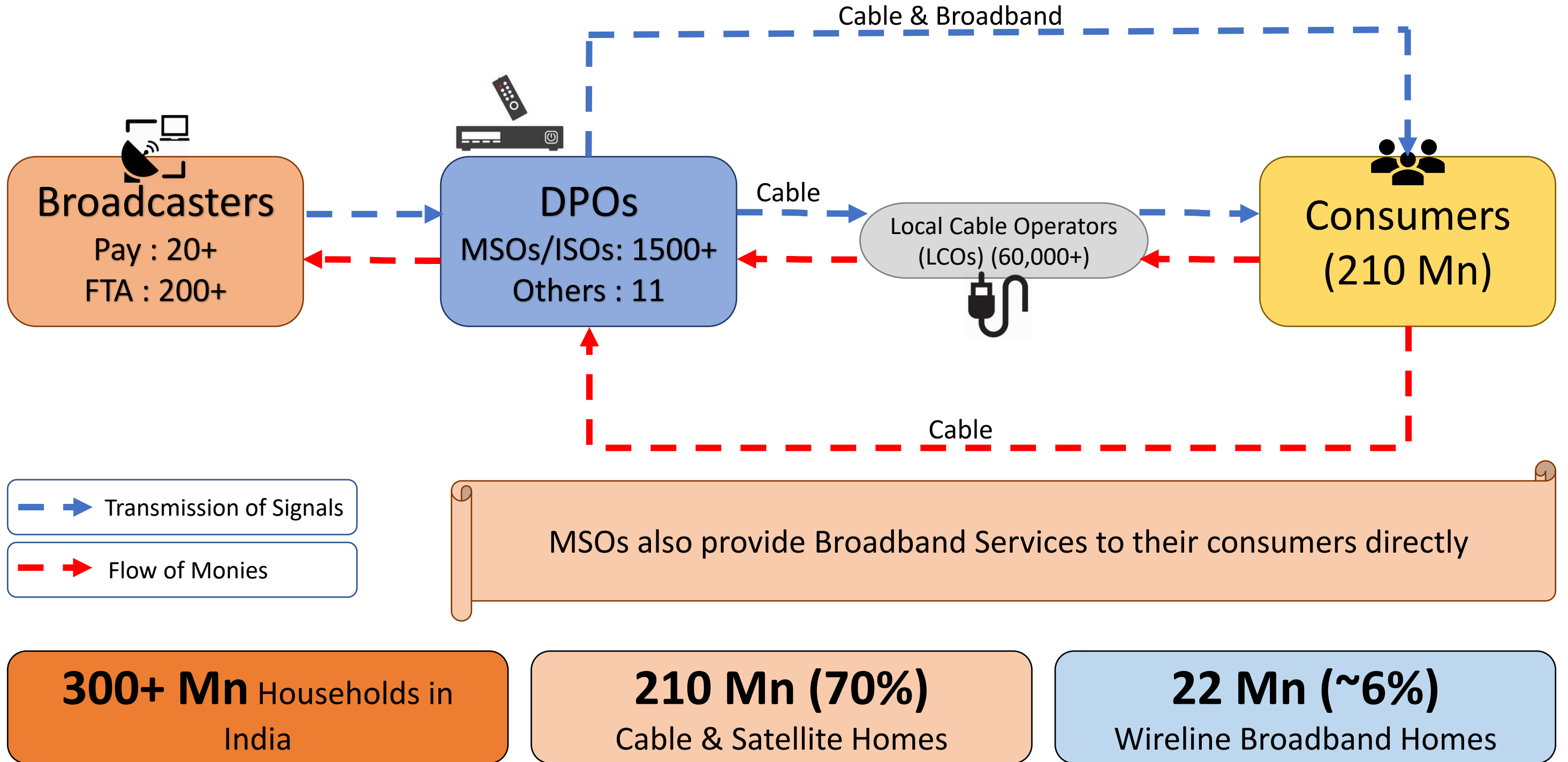

DPO = Distribution Platform Operators
Other DPOs : Head-end in the Sky (HITS) = (1); IPTV = (5); Direct to Home (DTH) = (5)

* Source : TV Universe Estimates 2020, BARC



Industry at a Glance

¹ TV Industry Revenues in ₹ Bn

■ Advertisement ■ Subscription

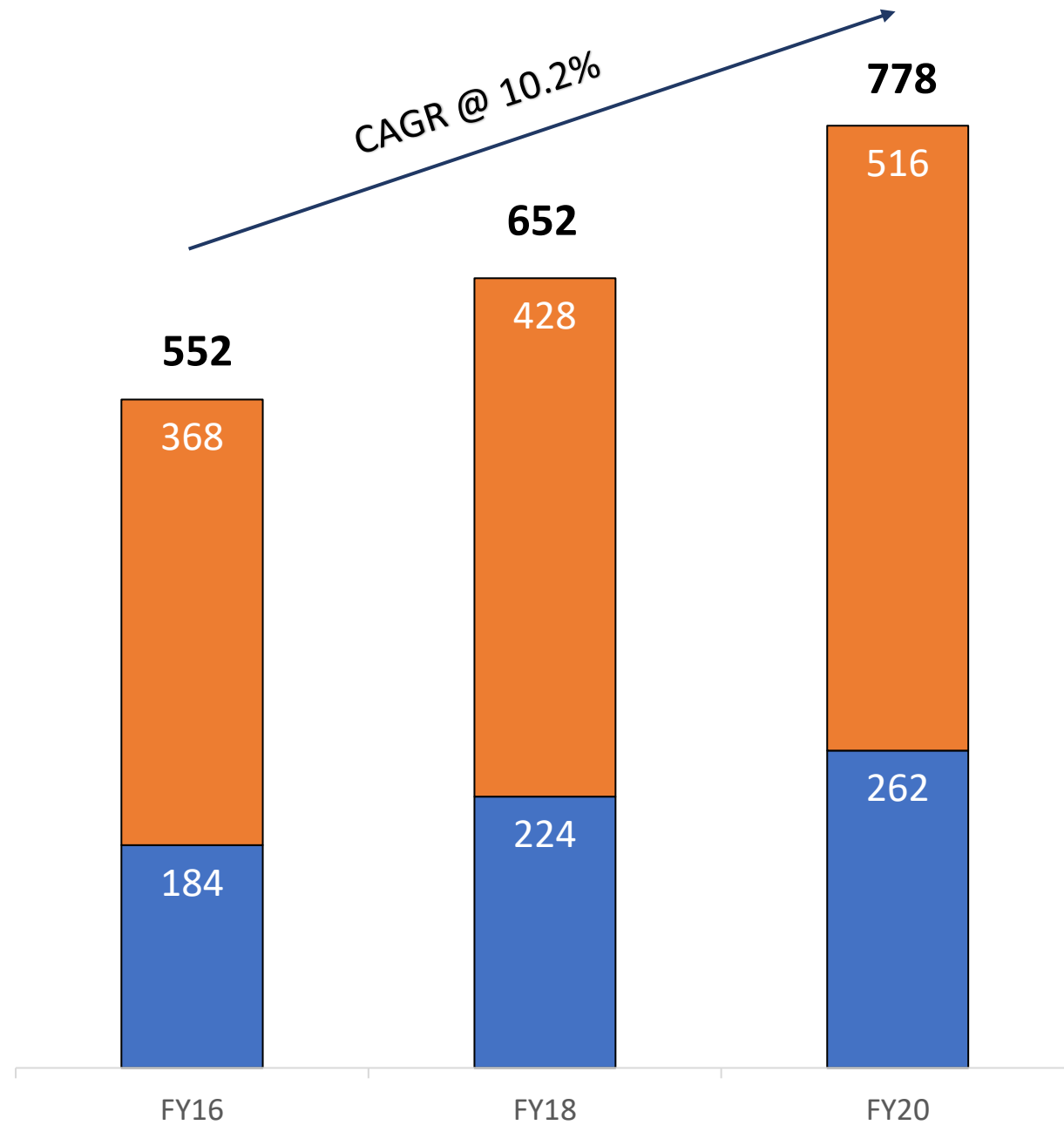

² TV Households in Mn

■ Free ■ Pay

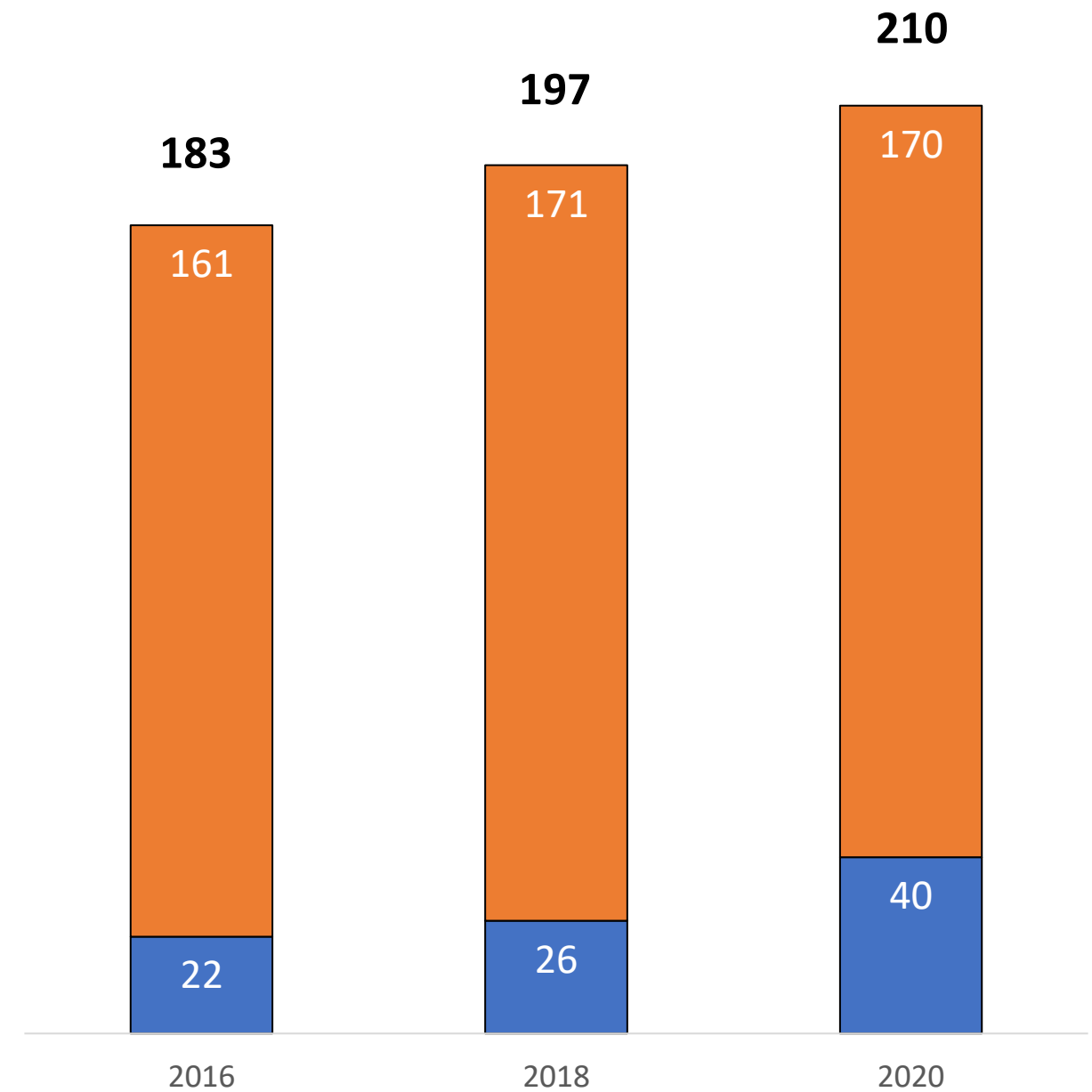

Source :

1. KPMG India's Report Media and Entertainment, 2020
2. TV Universe Estimates 2020, BARC

* FY = Apr- Mar



Wireline Broadband % Penetration of Total HHs# Around the Globe

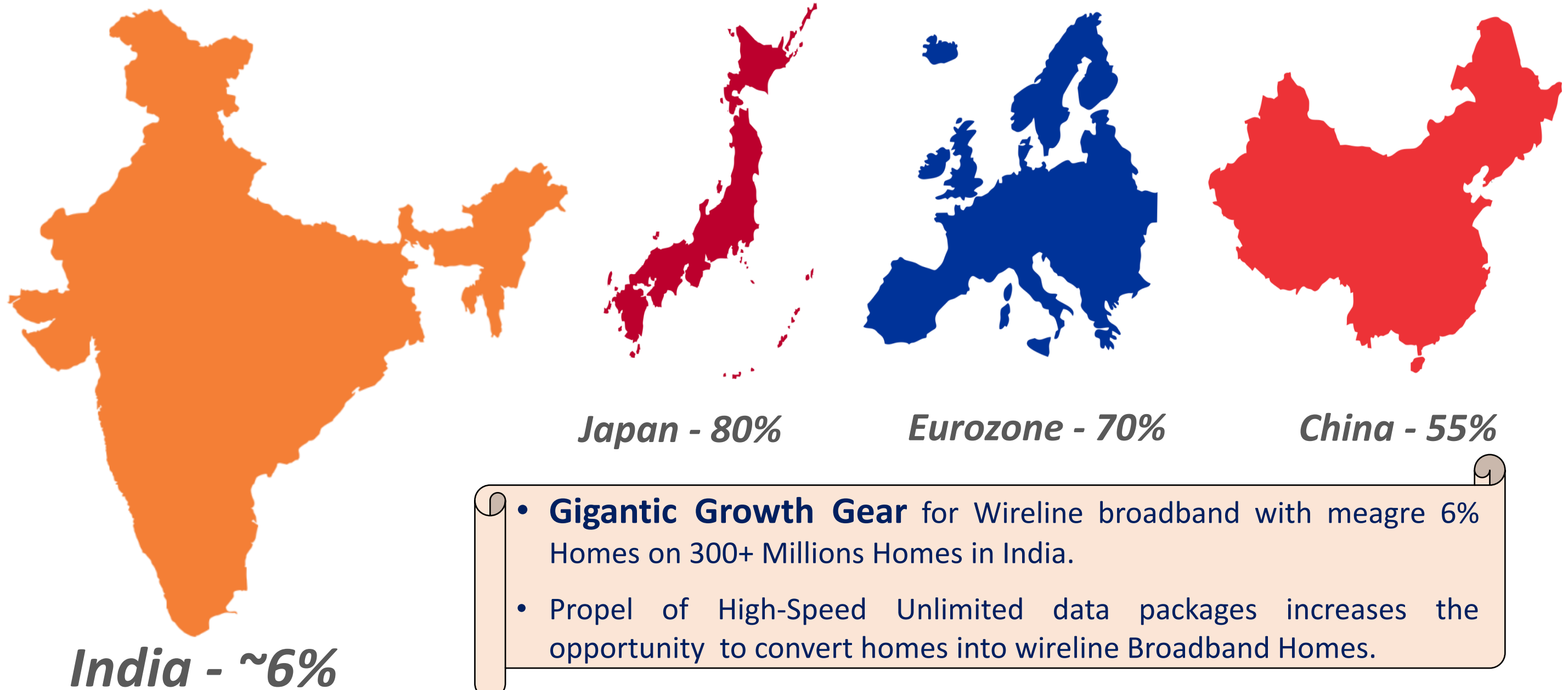

- **Gigantic Growth Gear** for Wireline broadband with meagre 6% Homes on 300+ Millions Homes in India.
- Propel of High-Speed Unlimited data packages increases the opportunity to convert homes into wireline Broadband Homes.



Hybrid

- Provide CATV services as a bundle
 - ❖ With Broadband & OTT services
- Tie-up with different service providers
- Up-sell current customers & add new customers.
- **Launched in Q3 FY22**

Expansion

- Expand GTPL Footprints in Existing Markets.
- Venture into New Markets through acquisitions and consolidations.

Broadband

- Expansion through business partners;
Launched in Q3 FY22
- Cross-sell to 10+ Mn CATV Households.
- Increased Broadband penetration in Rural Gujarat.

High Quality Technology and Infrastructure

- Capitalize and Monetize GPON infrastructure to provide High Speed, High Volume Broadband Services
- Enhancing digital infrastructure implementation capabilities





Key KPIs

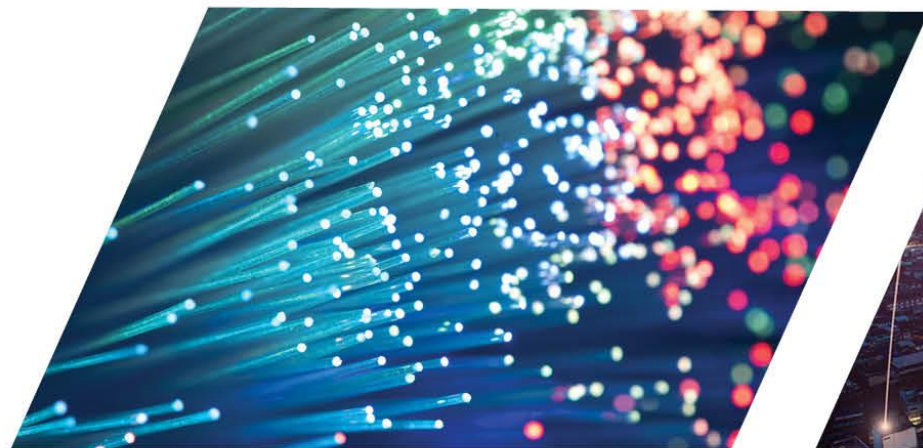

KEY KPIs : CATV Business : Quarterly : Consolidated*

Active Subscribers¹ (Mn)

Paying Subscribers (Mn)

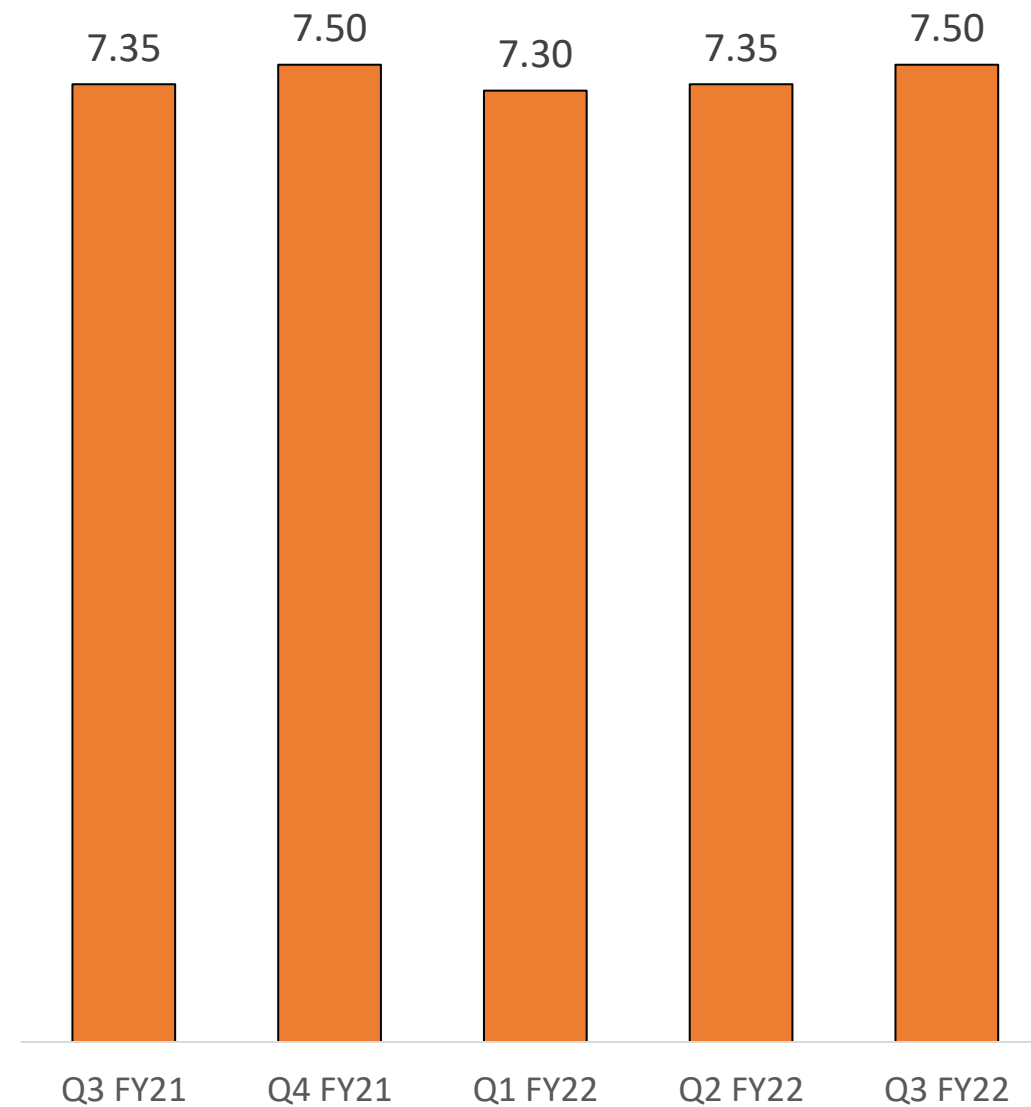
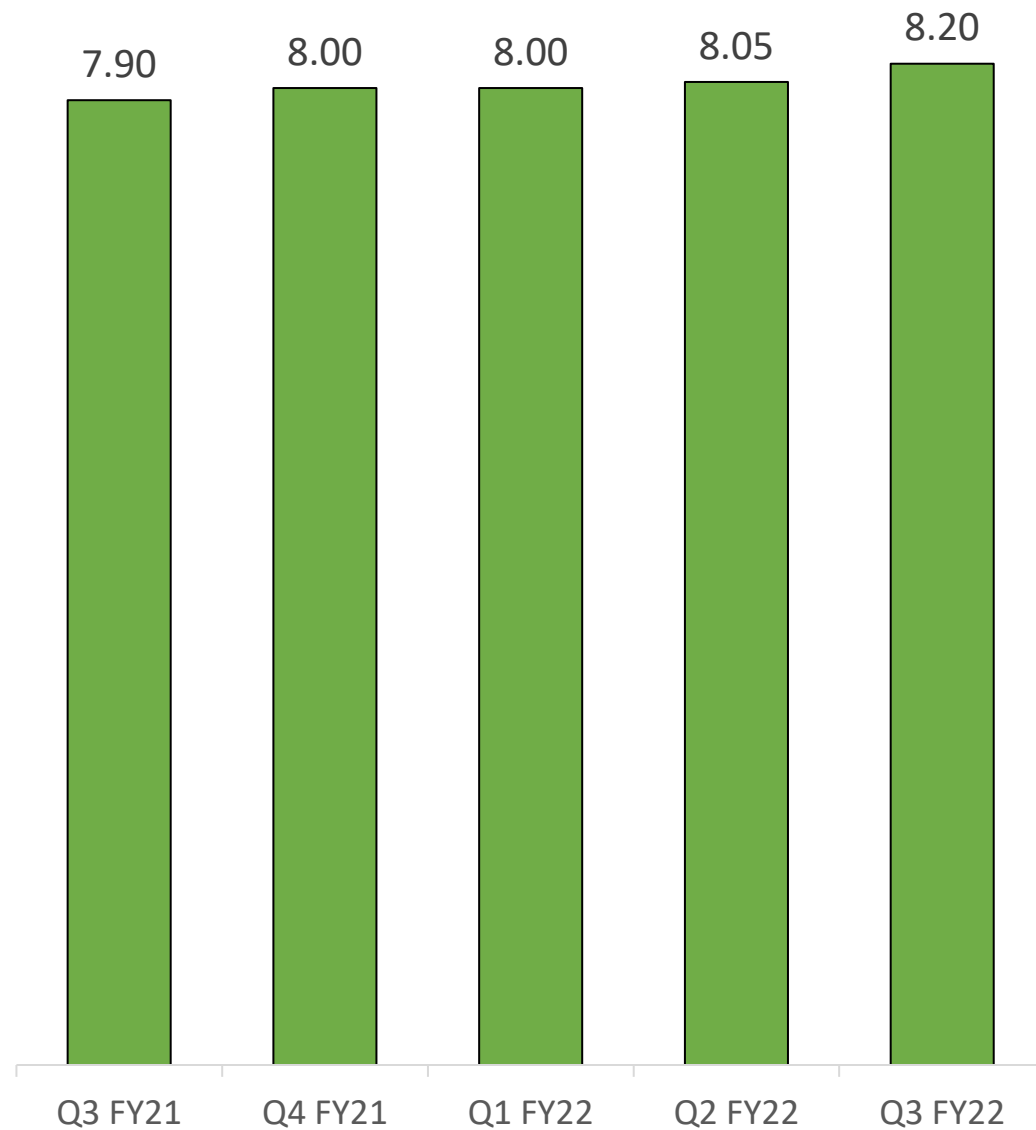

KEY KPIs : Broadband Business : Quarterly*

Home-pass (Mn)

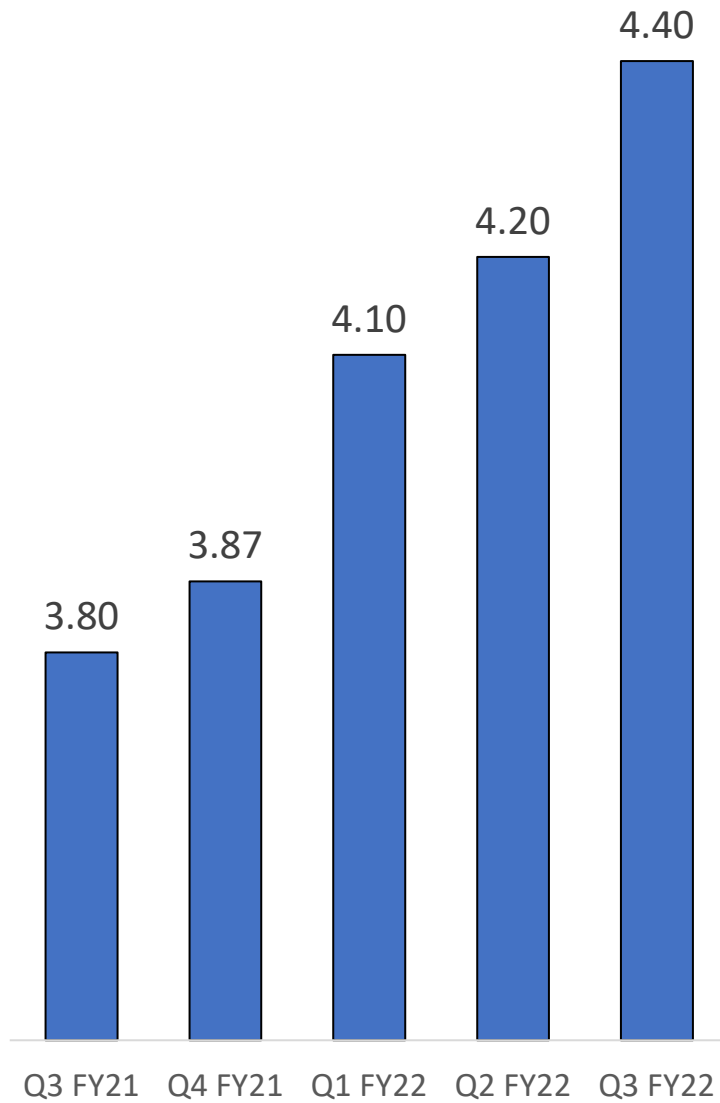

530K New Home-Pass in 9M FY22

Active Subscribers ('000)

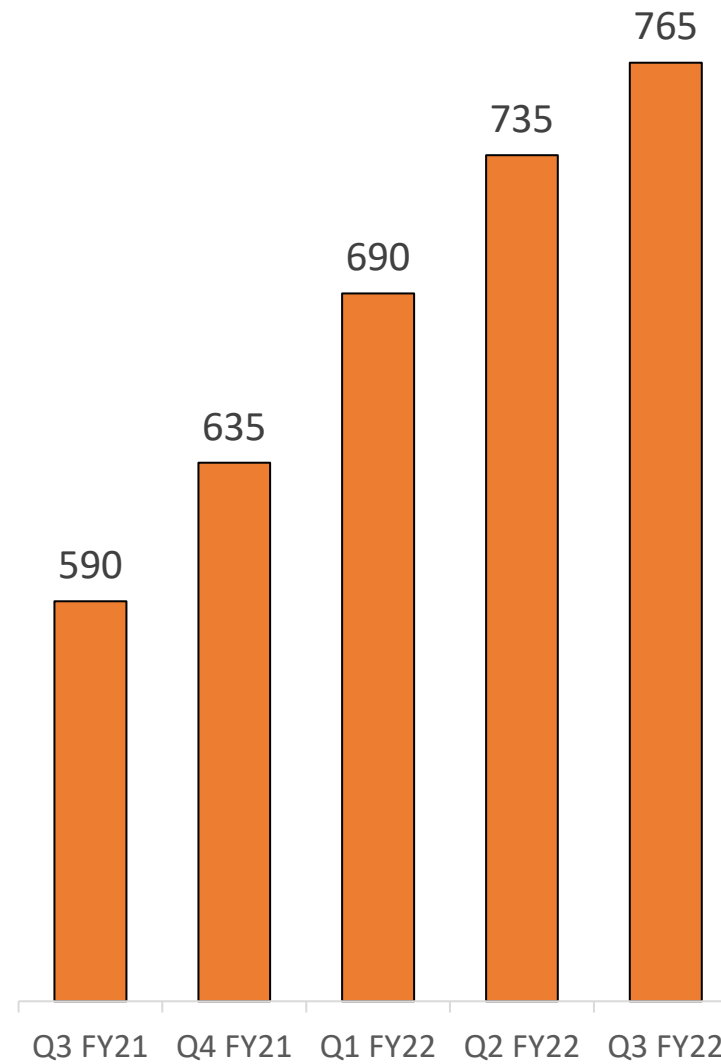

#ACB increased by 130K in 9M FY22

ARPU (₹) (Net of Taxes)

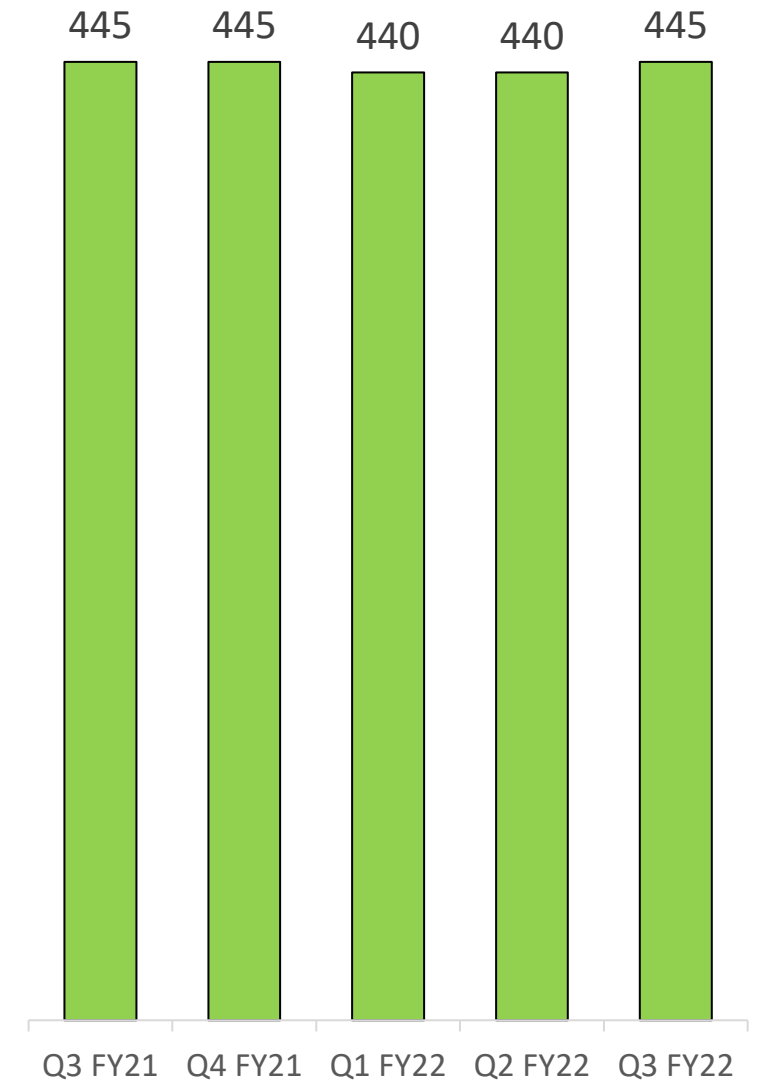

Maintained ARPU





**Consolidated
Financials**

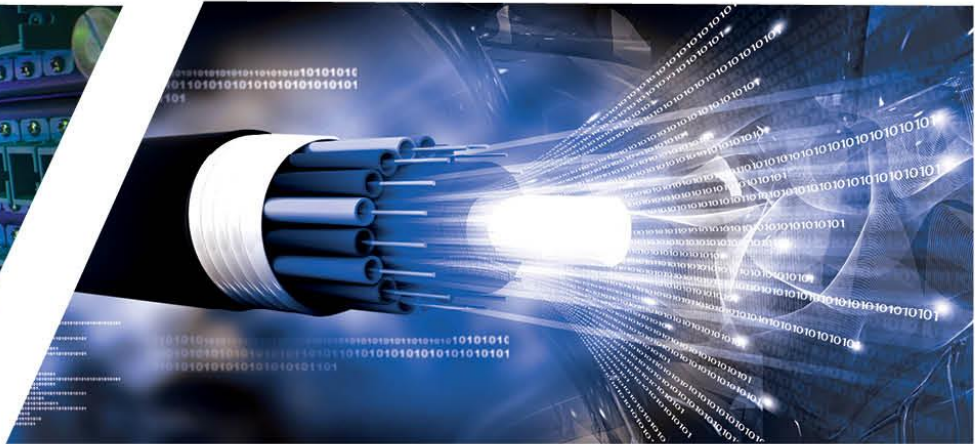

Financial Highlights : Consolidated*

(Ex EPC)



1 Revenue



Total Revenue up by 16% 9M-o-9M; 9% Y-o-Y; 2% Q-o-Q
ISP Revenue up by 51% 9M-o-9M; 35% Y-o-Y; 5% Q-o-Q

2 Expenses



Finance cost down by 42% 9M-o-9M

3 EBITDA



EBITDA of ₹ 4,277 Mn in 9M FY22; ₹ 1,472 Mn in Q3 FY22
Up ₹ 245 Mn (6%) 9M-o-9M; ₹ 28 Mn (2%) Q-o-Q
EBITDA Margin stands at 24.1% in Q3 FY22

4 PAT



PAT (Incl. EPC) of ₹ 1,454 Mn in 9M FY22; ₹ 546 Mn in Q3 FY22
Up by ₹ 140 Mn (11%) 9M-o-9M; ₹ 113 Mn (26%) Q-o-Q



Financial Performance Trend: Consolidated*

(Ex EPC)

Total Revenue (In ₹ Mn)

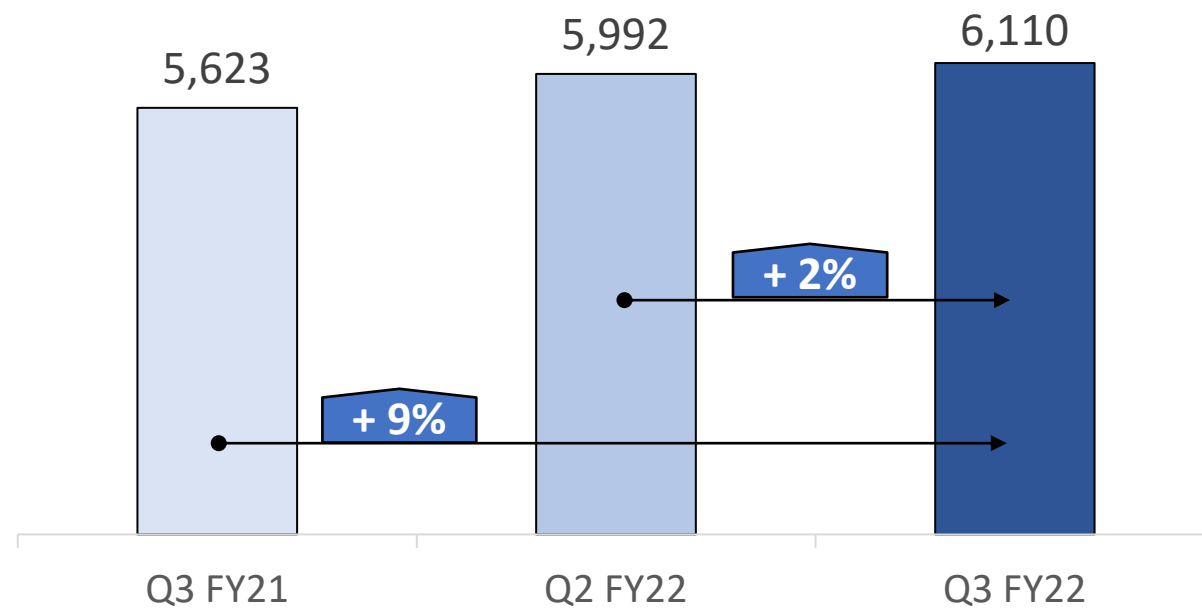

Quarterly

EBITDA (In ₹ Mn)

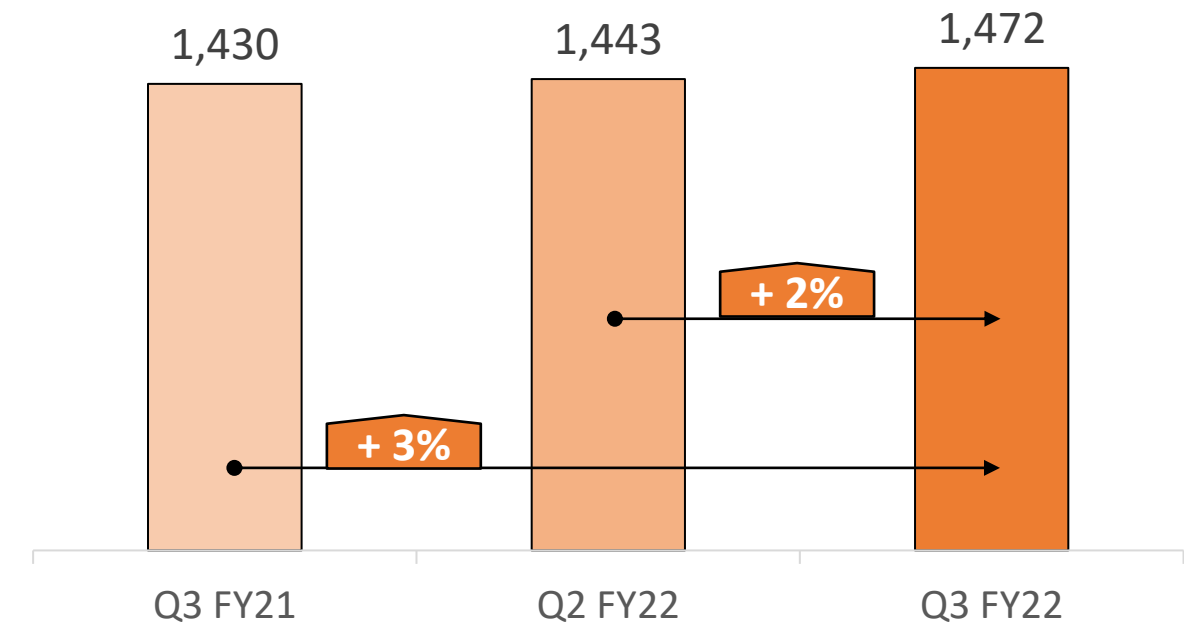

9 Months

* FY = Apr-Mar, Q1 = Apr-Jun, Q2 = Jul-Sep, Q3 = Oct-Dec, 9M = Apr-Dec

Note : Financial figures are excluding EPC contract



Financial Performance Trend: Consolidated*

(Ex EPC)

Subscription Revenue (In ₹ Mn)

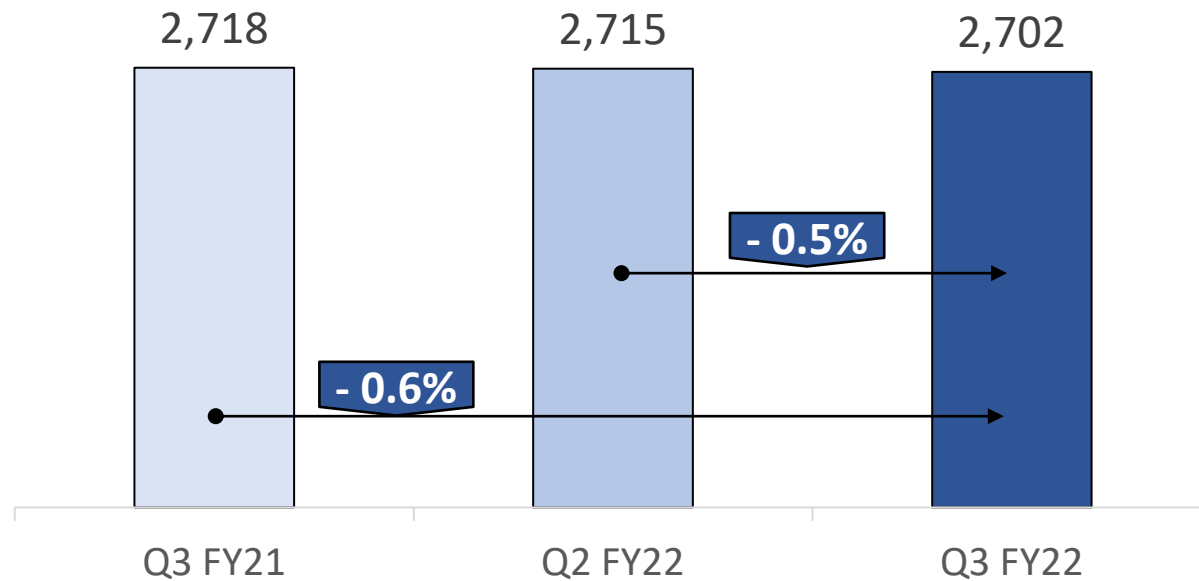

ISP Revenue (In ₹ Mn)

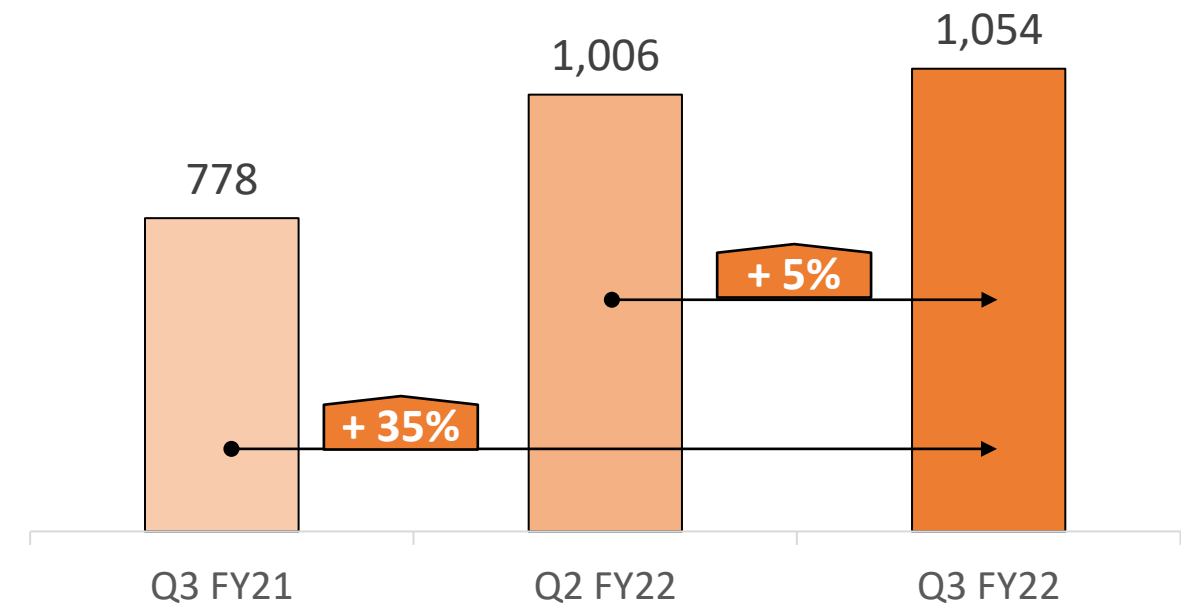

Quarterly

9 Months

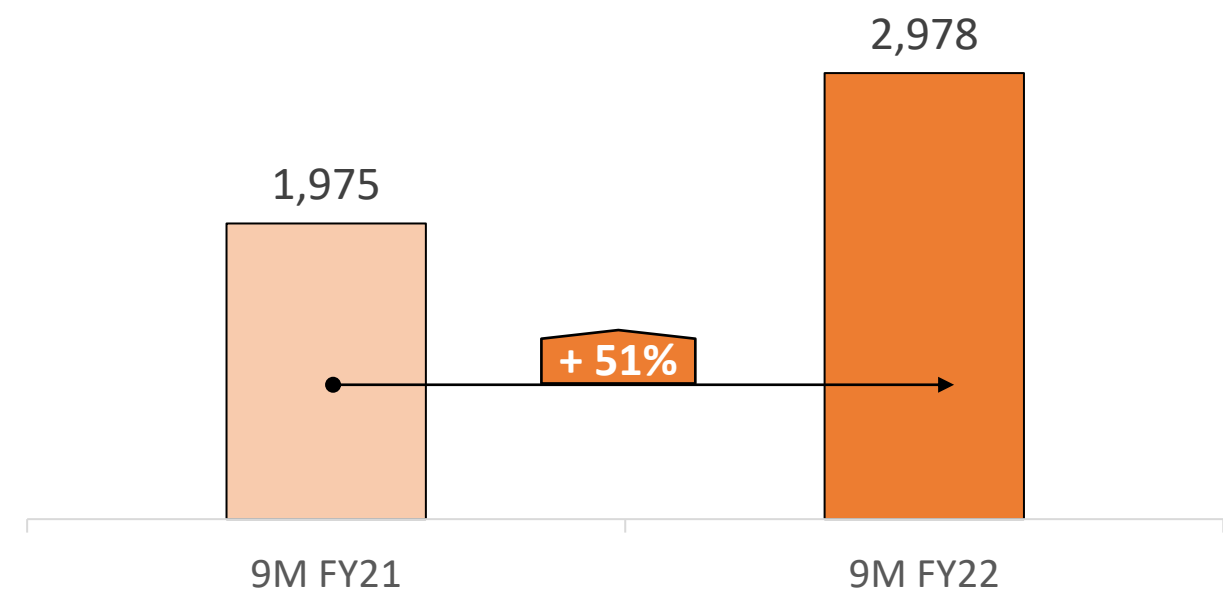
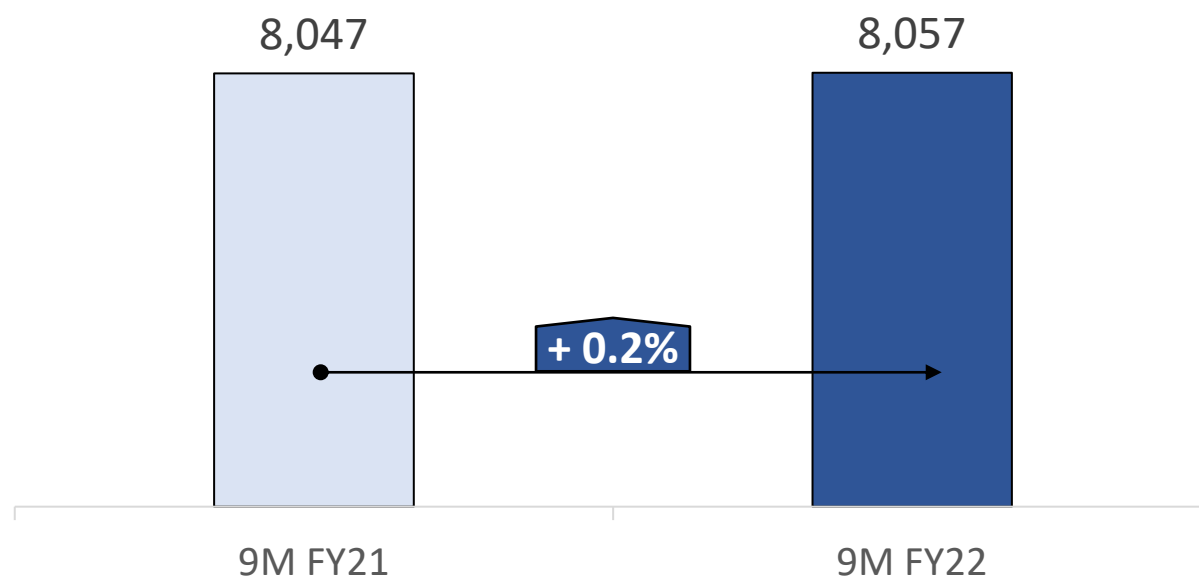

* FY = Apr-Mar, Q1 = Apr-Jun, Q2 = Jul-Sep, Q3 = Oct-Dec, 9M = Apr-Dec

Note : Financial figures are excluding EPC contract



Profit & Loss Statement : Consolidated* : 9M-o-9M

Particulars	9M FY22 Ex. EPC	9M FY22 EPC Contract	9M FY22 Total	9M FY21 Ex. EPC	9M FY21 EPC Contract	9M FY21 Total	9M-o-9M% (Ex. EPC)	FY21 Ex. EPC	FY21 EPC Contract	FY21 Total
Revenue										
Subscription CATV	8,057	-	8,057	8,047	-	8,047	0%	10,712	-	10,712
Revenue from EPC contract	-	343	343	-	1,929	1,929	-	-	3,815	3,815
Broadband ISP	2,978	-	2,978	1,975	-	1,975	51%	2,792	-	2,792
Placement / Carriage / Marketing Incentive	5,529	-	5,529	4,179	-	4,179	32%	5,975	-	5,975
Activation	444	-	444	740	-	740	-40%	924	-	924
Other Operating Income	618	-	618	314	-	314	97%	452	-	452
Other Income	319	1	320	239	1	240	33%	629	2	630
Total Income	17,945	344	18,288	15,493	1,930	17,423	16%	21,484	3,816	25,300
Expenditure										
Pay Channel Cost	9,001	-	9,001	7,492	-	7,492	20%	10,418	-	10,418
EPC cost of material consumed & sub contracting cost	-	320	320	-	1,792	1,792	-	-	3,548	3,548
Employee Cost	881	-	881	857	-	857	3%	1,148	-	1,148
Other Operating, Admin & Selling Exp.	3,786	-	3,786	3,113	-	3,113	22%	4,463	-	4,463
Total Expenditure	13,668	320	13,988	11,461	1,792	13,254	19%	16,029	3,548	19,577
EBITDA	4,277	24	4,301	4,032	138	4,170	6%	5,455	268	5,724
EBITDA %	23.8%	6.9%	23.5%	26.0%	7.1%	23.9%		25.4%	7.0%	22.6%
Depreciation/Amortization	1,875	0	1,875	1,949	0	1,949	-4%	2,604	0	2,604
Finance cost	102	-	102	178	10	188	-42%	221	10	230
Profit before Tax & Exceptional item	2,299	24	2,323	1,905	128	2,032	21%	2,631	258	2,889
Exceptional item / Share of Profit/(Loss) from Associate and JVs	(130)	-	(130)	(10)	-	(10)		(10)	-	(10)
PBT	2,170	24	2,194	1,895	128	2,022	15%	2,621	258	2,879
Tax			573			535		-	-	775
PAT before Other Comprehensive Income			1,621			1,487	9%			2,104
(Add)/Less : Share of Non Controlling Interest			(169)			(175)				(223)
Add/(Less) Other Comprehensive Income			2			2				4
PAT			1,454			1,314	11%			1,885

In ₹ Mn

Exceptional Items (Loss on Insurance Claim Receivables) in Broadband of ₹ 124 Mn

* FY = Apr-Mar, Q1 = Apr-Jun, Q2 = Jul-Sep, Q3 = Oct-Dec, 9M = Apr-Dec

Note : PAT% are including EPC contract.



Profit & Loss Statement : Consolidated* : Q-o-Q

In ₹ Mn

Particulars	Q3 FY22 Ex. EPC	Q3 FY22 EPC Contract	Q3 FY22 Total	Q2 FY22 Ex. EPC	Q2 FY22 EPC Contract	Q2 FY22 Total	Q-o-Q% (Ex. EPC)	Q3 FY21 Ex. EPC	Q3 FY21 EPC Contract	Q3 FY21 Total	Y-o-Y% (Ex. EPC)	FY21 Ex. EPC	FY21 EPC Contract	FY21 Total
Revenue														
Subscription CATV	2,702	-	2,702	2,715	-	2,715	0%	2,718	-	2,718	-1%	10,712	-	10,712
Revenue from EPC contract	-	19	19	-	61	61	-	-	933	933	-	-	3,815	3,815
Broadband ISP	1,054	-	1,054	1,006	-	1,006	5%	778	-	778	35%	2,792	-	2,792
Placement / Carriage / Marketing Incentive Activation	1,859	-	1,859	1,800	-	1,800	3%	1,640	-	1,640	13%	5,975	-	5,975
Other Operating Income	132	-	132	150	-	150	-12%	251	-	251	-48%	924	-	924
Other Income	225	-	225	228	-	228	-1%	152	-	152	48%	452	-	452
Other Income	138	0	138	93	0	93	49%	84	0	84	64%	629	2	630
Total Income	6,110	19	6,130	5,992	61	6,052	2%	5,623	933	6,556	9%	21,484	3,816	25,300
Expenditure														
Pay Channel Cost	3,020	-	3,020	2,977	-	2,977	1%	2,771	-	2,771	9%	10,418	-	10,418
EPC cost of material consumed & sub contracting cost	-	18	18	-	56	56	-	-	868	868	-	-	3,548	3,548
Employee Cost	305	-	305	296	-	296	3%	280	-	280	9%	1,148	-	1,148
Other Operating, Admin & Selling Exp.	1,313	-	1,313	1,275	-	1,275	3%	1,142	-	1,142	15%	4,463	-	4,463
Total Expenditure	4,639	18	4,657	4,548	56	4,605	2%	4,193	868	5,061	11%	16,029	3,548	19,577
EBITDA	1,472	1	1,473	1,443	4	1,448	2%	1,430	65	1,495	3%	5,455	268	5,724
EBITDA %	24.1%	7.6%	24.0%	24.1%	7.1%	23.9%		25.4%	6.9%	22.8%		25.4%	7.0%	22.6%
Depreciation/Amortization	636	0	636	625	0	625	2%	689	0	689	-8%	2,604	0	2,604
Finance cost	53	-	53	33	-	33	61%	49	2	50	9%	221	10	230
Profit before Tax & Exceptional item	782	1	784	785	4	789	0%	693	63	755	13%	2,631	258	2,889
Exceptional item / Share of Profit/(Loss) from Associate and JVs	(2)	-	(2)	(127)	-	(127)		(6)	-	(6)		(10)	-	(10)
PBT	780	1	782	658	4	662	19%	687	63	750	14%	2,621	258	2,879
Tax			195			158				226				775
PAT before Other Comprehensive Income			586			504	16%			524	12%			2,104
(Add)/Less : Share of Non Controlling Interest			(40)			(73)				(71)				(223)
Add/(Less) Other Comprehensive Income			(0)			2				0				4
PAT			546			433	26%			452	21%			1,885

Exceptional Items (Loss on Insurance Claim Receivables) in Broadband of ₹ 124 Mn in Q2 FY22

* FY = Apr-Mar, Q1 = Apr-Jun, Q2 = Jul-Sep, Q3 = Oct-Dec

Note : PAT% are including EPC contract.



Financial Performance : Consolidated

Net Worth (In ₹ Mn)

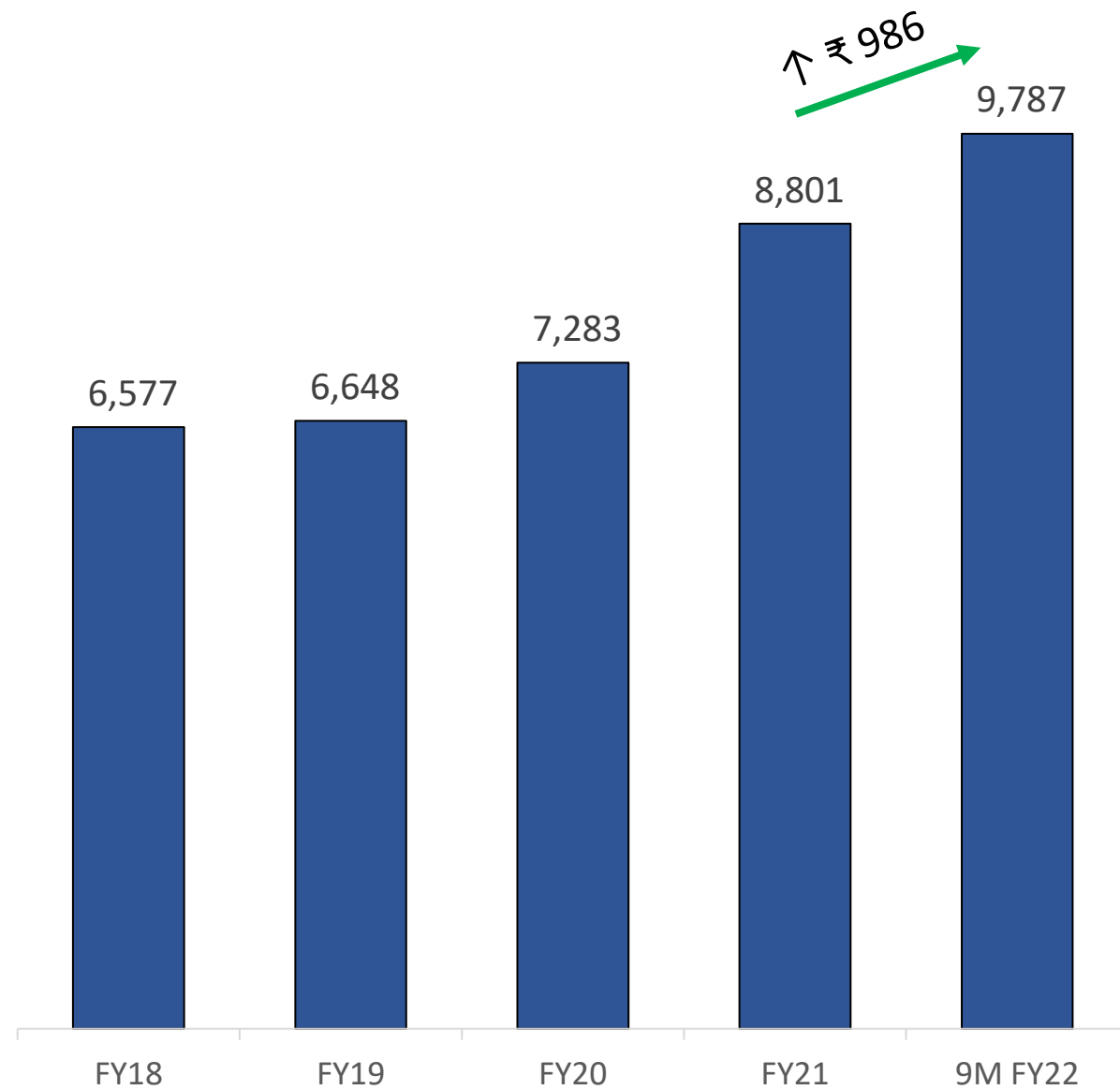

Net Debt (In ₹ Mn)

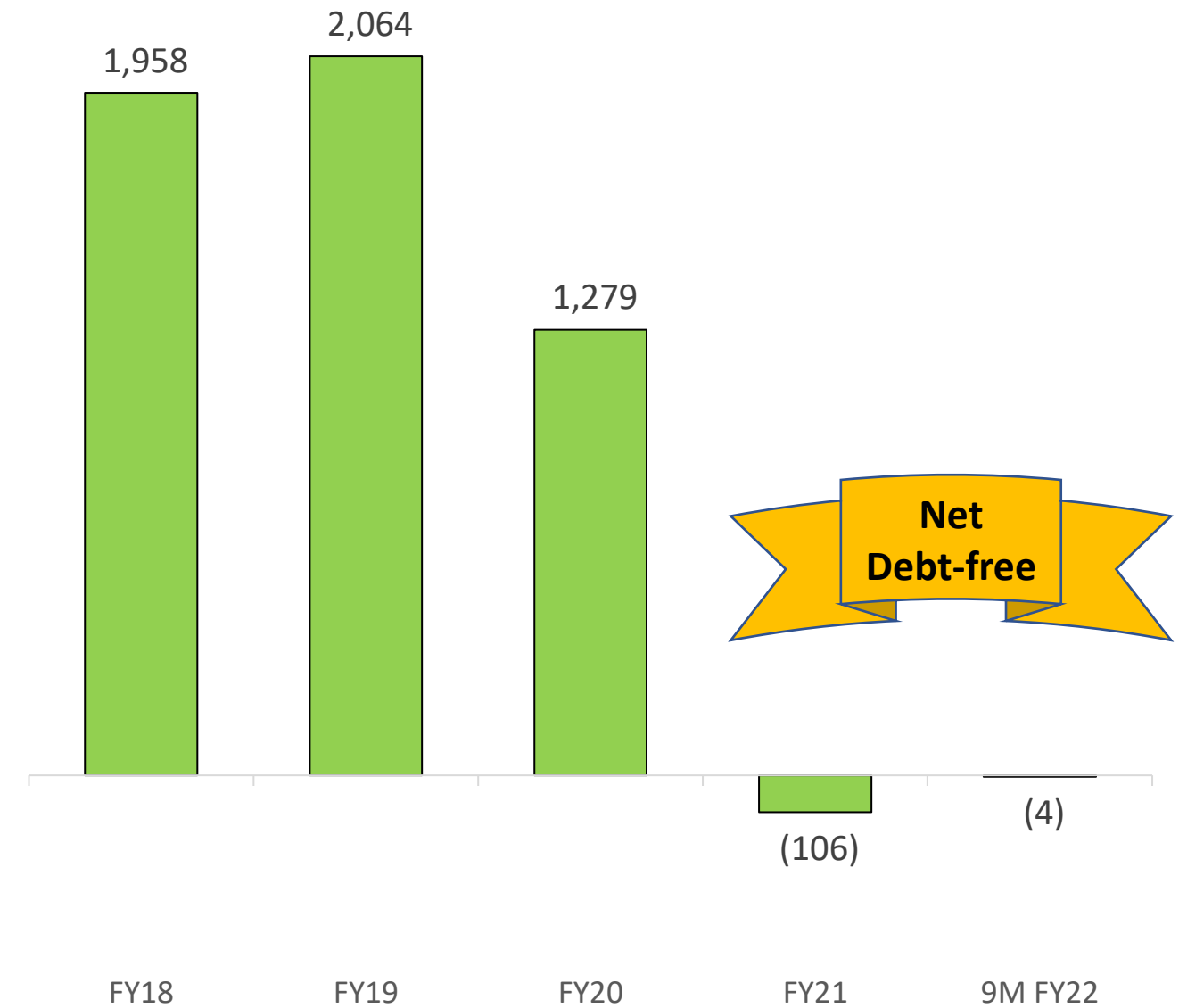

Standalone Financials

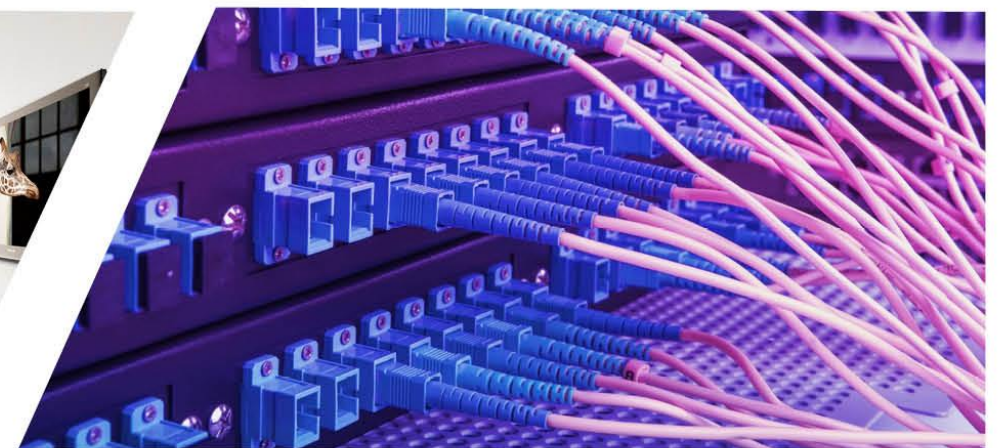
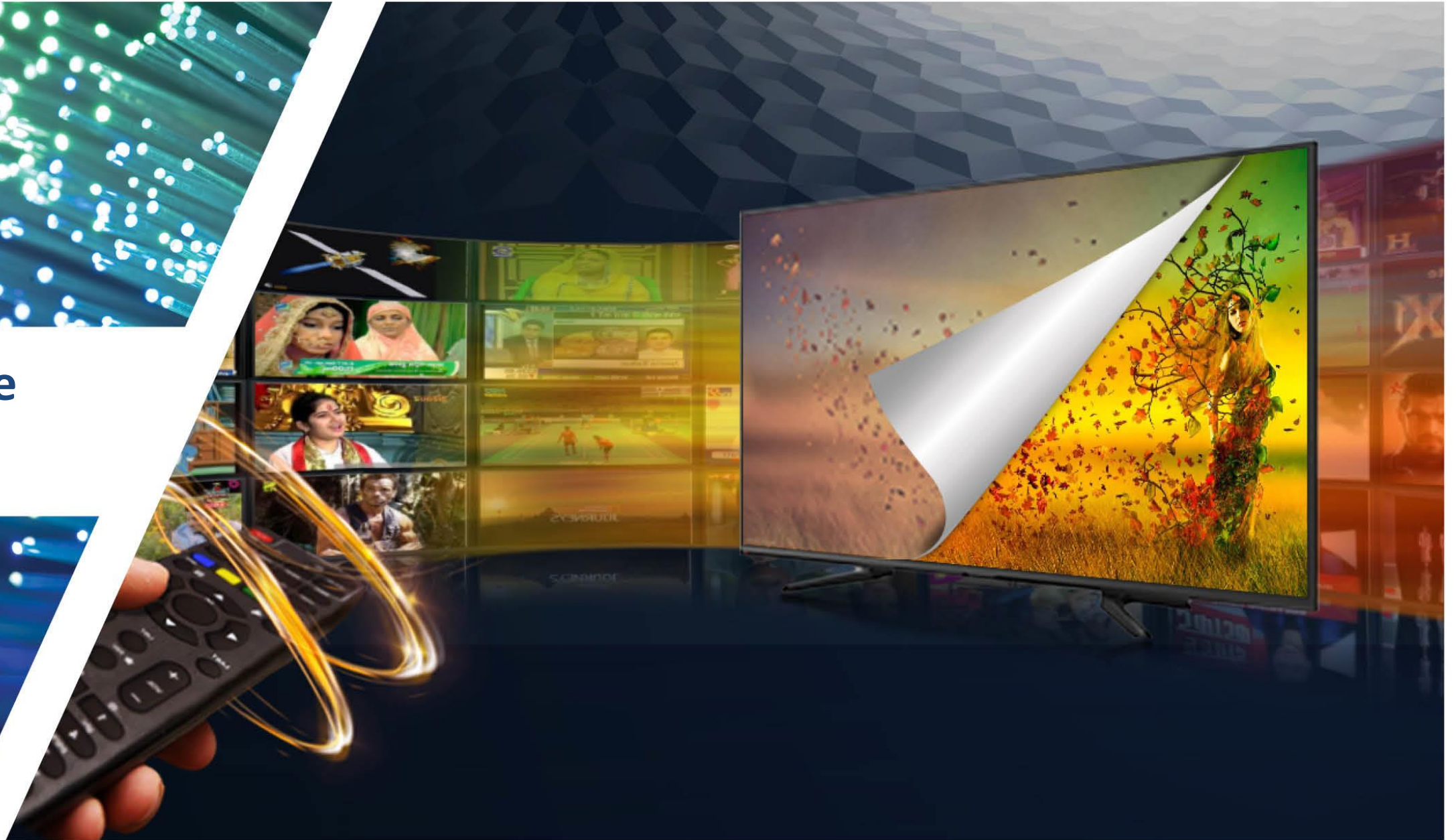

Financial Highlights : Standalone*

(Ex EPC)

1 Revenue



Total Revenue up by 10% 9M-o-9M; 6% Y-o-Y; 3% Q-o-Q
Subscription Revenue up by 1% 9M-o-9M; 1% Y-o-Y

2 Expenses



Finance cost down by 32% 9M-o-9M

3 EBITDA



EBITDA of ₹ 2,425 Mn in 9M FY22; ₹ 852 Mn in Q3 FY22
Up by ₹ 14 Mn (1%) 9M-o-9M; ₹ 58 Mn (7%) Q-o-Q
EBITDA Margin stands at 22.1% in Q3 FY22; up by 94 bps Q-o-Q

4 Earnings



PAT (Incl. EPC) of ₹ 991 Mn in 9M FY22; ₹ 354 Mn in Q3 FY22
Up by ₹ 74 Mn (8%) 9M-o-9M; ₹ 21 Mn (6%) Q-o-Q



Financial Performance Trend: Standalone* (Ex EPC)

Total Revenue (In ₹ Mn)

Quarterly

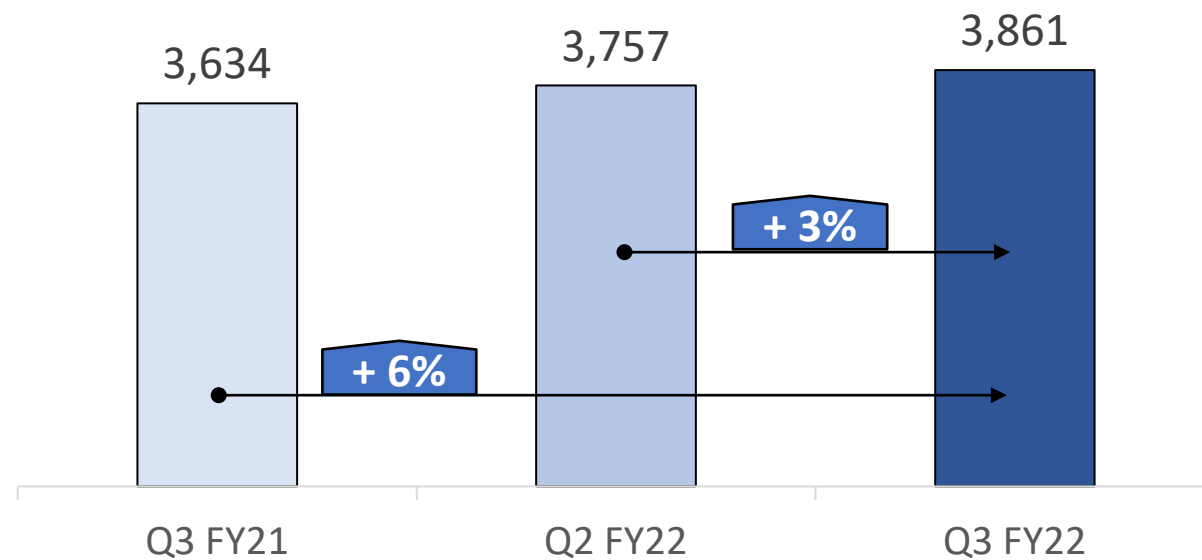

EBITDA (In ₹ Mn)

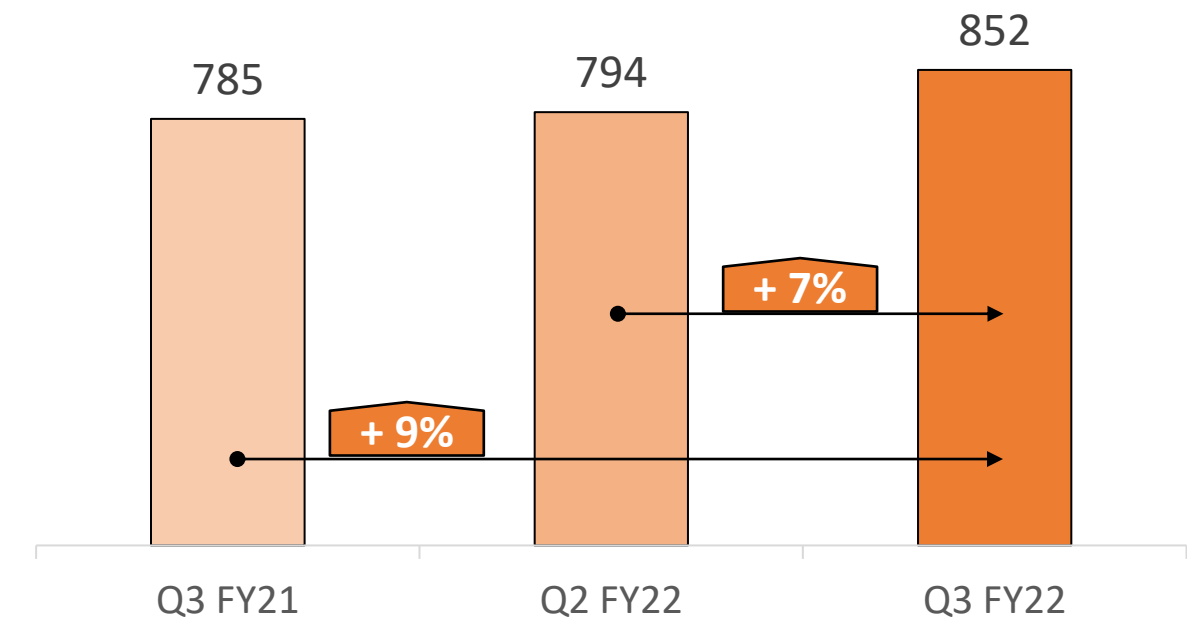

9 Months

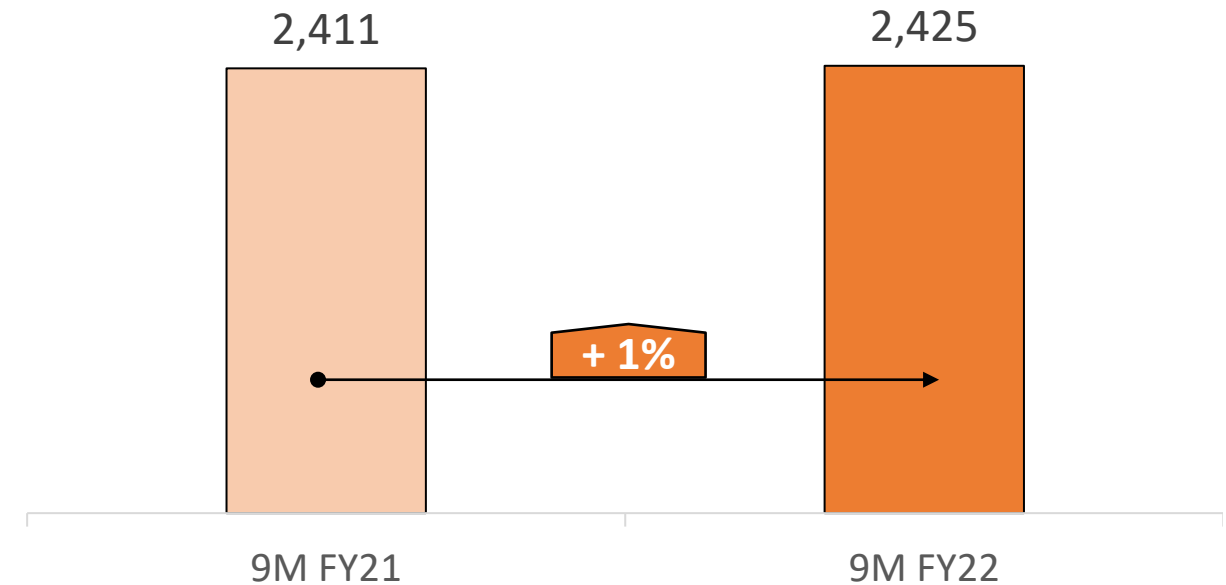
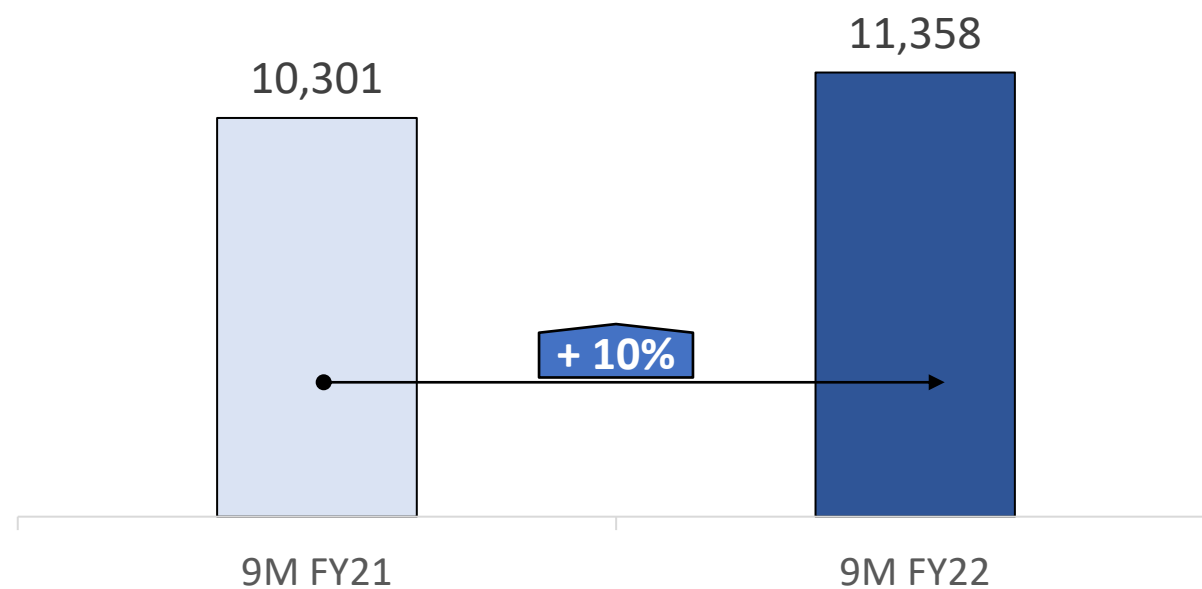

* FY = Apr-Mar, Q1 = Apr-Jun, Q2 = Jul-Sep, Q3 = Oct-Dec, 9M = Apr-Dec

Note : Financial figures are excluding EPC contract



Profit & Loss Statement : Standalone* : 9M-o-9M

In ₹ Mn

Particulars	9M FY22 Ex. EPC	9M FY22 EPC	9M FY22 Total	9M FY21 Ex. EPC	9M FY21 EPC	9M FY21 Total	9M-o-9M% (Ex. EPC)	FY21 Ex. EPC	FY21 EPC Contract	FY21 Total
Revenue										
Subscription CATV	5,601	-	5,601	5,545	-	5,545	1%	7,397	-	7,397
Revenue from EPC contract	-	343	343	-	1,929	1,929	-	-	3,815	3,815
Placement / Carriage / Marketing Incentive	4,415	-	4,415	3,639	-	3,639	21%	5,076	-	5,076
Activation	252	-	252	499	-	499	-50%	604	-	604
Other Operating Income	822	-	822	456	-	456	80%	663	-	663
Other Income	269	1	270	162	1	163	66%	488	2	489
Total Income	11,358	344	11,702	10,301	1,930	12,231	10%	14,229	3,816	18,045
Expenditure										
Pay Channel Cost	6,440	-	6,440	5,591	-	5,591	15%	7,690	-	7,690
EPC cost of material consumed & sub contracting cost	-	320	320	-	1,792	1,792	-	-	3,548	3,548
Employee Cost	438	-	438	441	-	441	-1%	589	-	589
Other Operating, Admin & Selling Exp.	2,055	-	2,055	1,859	-	1,859	11%	2,658	-	2,658
Total Expenditure	8,933	320	9,253	7,891	1,792	9,683	13%	10,937	3,548	14,485
EBITDA	2,425	24	2,449	2,411	138	2,548	1%	3,292	268	3,560
EBITDA %	21.3%	6.9%	20.9%	23.4%	7.1%	20.8%		23.1%	7.0%	19.7%
Depreciation/Amortization	1,022	0	1,022	1,171	0	1,171	-13%	1,558	0	1,558
Finance cost	89	-	89	131	10	141	-32%	165	10	174
Profit before Tax & Exceptional item	1,314	24	1,338	1,108	128	1,236	19%	1,569	258	1,828
Exceptional item / Share of Profit/(Loss) from Associate and JVs	-	-	-	-	-	-		-	-	-
PBT	1,314	24	1,338	1,108	128	1,236	19%	1,569	258	1,828
Tax			348			320				502
PAT before Other Comprehensive Income			990			916	8%			1,326
Add/(Less) Other Comprehensive Income			1			1				3
PAT			991			917	8%			1,329

* FY = Apr-Mar, 9M = Apr-Dec



Profit & Loss Statement : Standalone* : Q-o-Q

In ₹ Mn

Particulars	Q3 FY22 Ex. EPC	Q3 FY22 EPC Contract	Q3 FY22 Total	Q2 FY22 Ex. EPC	Q2 FY22 EPC Contract	Q2 FY22 Total	Q-o-Q% (Ex. EPC)	Q3 FY21 Ex. EPC	Q3 FY21 EPC Contract	Q3 FY21 Total	Y-o-Y% (Ex. EPC)	FY21 Ex. EPC	FY21 EPC Contract	FY21 Total
Revenue														
Subscription CATV	1,878	-	1,878	1,887	-	1,887	0%	1,855	-	1,855	1%	7,397	-	7,397
Revenue from EPC contract	-	19	19	-	61	61	-	-	933	933	-	-	3,815	3,815
Placement / Carriage / Marketing Incentive	1,488	-	1,488	1,434	-	1,434	4%	1,357	-	1,357	10%	5,076	-	5,076
Activation	82	-	82	77	-	77	7%	175	-	175	-53%	604	-	604
Other Operating Income	303	-	303	288	-	288	5%	195	-	195	56%	663	-	663
Other Income	110	0	111	71	0	71	55%	53	0	53	110%	488	2	489
Total Income	3,861	19	3,881	3,757	61	3,818	3%	3,634	933	4,567	6%	14,229	3,816	18,045
Expenditure														
Pay Channel Cost	2,145	-	2,145	2,133	-	2,133	1%	2,022	-	2,022	6%	7,690	-	7,690
EPC cost of material consumed & sub contracting cost	-	18	18	-	56	56	-	-	868	868	-	-	3,548	3,548
Employee Cost	149	-	149	150	-	150	0%	137	-	137	9%	589	-	589
Other Operating, Admin & Selling Exp.	715	-	715	680	-	680	5%	691	-	691	3%	2,658	-	2,658
Total Expenditure	3,009	18	3,027	2,963	56	3,020	2%	2,849	868	3,718	6%	10,937	3,548	14,485
EBITDA	852	1	854	794	4	798	7%	785	65	849	9%	3,292	268	3,560
EBITDA %	22.1%	7.6%	22.0%	21.1%	7.1%	20.9%		21.6%	6.9%	18.6%		23.1%	7.0%	19.7%
Depreciation/Amortization	343	0	343	345	0	345	0%	414	0	414	-17%	1,558	0	1,558
Finance cost	41	-	41	22	-	22	86%	37	2	38	13%	165	10	174
Profit before Tax & Exceptional item	468	1	469	427	4	431	10%	334	63	397	40%	1,569	258	1,828
Exceptional item / Share of Profit/(Loss) from Associate and JVs	-			-				-				-		
PBT	468	1	469	427	4	431	10%	334	63	397	40%	1,569	258	1,828
Tax			116			100				126				502
PAT before Other Comprehensive Income			354			331	7%			271	30%			1,326
Add/(Less) Other Comprehensive Income						1								3
PAT			354			332	6%			271	30%			1,329



Awards & Accreditation

Excellence

in

Finance Transformation

- by **KamiKaze**



Investor Conference Call Details



EMKAY GLOBAL FINANCIAL SERVICES LTD.
is pleased to invite you for a conference call to discuss the Q3 & 9M FY22 earnings with

Mr. Anirudhsinh Jadeja - Promoter and Managing Director
Mr. Rajan Gupta - Chairman and Non-Executive Director
Mr. Piyush Pankaj - Business Head - CATV & Chief Strategy Officer
Mr. Anil Bothra - Chief Financial Officer



GTPL Hathway
On Monday, January 17, 2022 at 04:00 PM (IST)

[Pre-register to avoid wait time and Express Join with DiamondPass™](#)

Dial-in Numbers
Universal Access : +91 22 6280 1325 / +91 22 7115 8226

International Toll Free :
Argentina: 0080014243444 / Australia: 1800053698 / Belgium: 0080014243444 / Canada: 01180014243444 /
China: 4008428405 / France: 0800914745 / Germany: 0080014243444 / Hong Kong: 800964448 /
Italy: 0080014243444 / Japan: 00531161110 / Netherlands: 08000229808 / Poland: 008001124248 /
Singapore: 8001012045 / South Korea: 00180014243444 / Thailand: 00180014243444 /
UK: 0808101157

International Toll :
HongKong: +852 30106877 / Japan: +81 345899421 / Singapore: +65 31575746 / SouthAfrica: +27 110623033 /
UK: +44 2034785524 / USA: +1 3233868721



For further information please contact:
Mr. Naval Seth
naval.seth@emkayglobal.com
Tel.: +91 22 6624 2414



Your success is our success



The information contained in this presentation is only current as of its date. All actions and statements made herein or otherwise shall be subject to the applicable laws and regulations as amended from time to time. There is no representation that all information relating to the context has been taken care off in the presentation and neither we undertake any obligation as to the regular updating of the information as a result of new information, future events or otherwise. We will accept no liability whatsoever for any loss arising directly or indirectly from the use of, reliance of any information contained in this presentation or for any omission of the information. The information shall not be distributed or used by any person or entity in any jurisdiction or countries were such distribution or use would be contrary to the applicable laws or Regulations. It is advised that prior to acting upon this presentation independent consultation / advise may be obtained and necessary due diligence, investigation etc. may be done at your end. You may also contact us directly for any questions or clarifications at our end. This presentation contains certain statements of future expectations and other forward-looking statements, including those relating to our general business plans and strategy, our future financial condition and growth prospects, and future developments in our industry and our competitive and regulatory environment. In addition to statements which are forward looking by reason of context, the words 'may, will, should, expects, plans, intends, anticipates, believes, estimates, predicts, potential or continue and similar expressions identify forward looking statements. Actual results, performances or events may differ materially from these forward-looking statements including the plans, objectives, expectations, estimates and intentions expressed in forward looking statements due to a number of factors, including without limitation future changes or developments in our business, our competitive environment, telecommunications technology and application, and political, economic, legal and social conditions in India. It is cautioned that the foregoing list is not exhaustive This presentation is not being used in connection with any invitation of an offer or an offer of securities and should not be used as a basis for any investment decision.





Mr. Piyush Pankaj
Business Head - CATV & Chief Strategy Officer
Email: piyush.pankaj@gtpl.net

DICKENSON

IR Consultants

Mr. Mehul Mehta
Contact: +91 98202 80325

Mr. Hiral Keniya
Contact: +91 90296 62801
Email: gtplhathway@dickensonworld.com

THANK YOU

