



July 14, 2022

BSE Limited

Phiroze Jeejeebhoy Towers,
Dalal Street, Mumbai – 400051

National Stock Exchange of India Limited

Exchange Plaza, Bandra Kurla Complex,
Bandra East, Mumbai – 400051

BSE - 500495

NSE - ESCORTS

Dear Sir/ Madam,

Sub: Presentation at the 76th Annual General Meeting

Please find enclosed herewith Presentation to be made to the shareholder of the Company at the 76th Annual General Meeting to be held on July 14, 2022 at 12:00 Noon (Indian Standard Time).

This is for your information.

Thanking you,
Yours faithfully,
For **Escorts Kubota Limited**

Satyendra Chauhan
Company Secretary & Compliance Officer



Encl.: As Above

Note: The Equity Shares of the Company were listed on the Delhi Stock Exchange Limited (DSE). However, DSE has been de-recognised and allowed to exit as a stock exchange by SEBI by way of SEBI's Order No. WTM/ SR/ SEBI/ MRD-DSA/ 04/ 01/ 2017 dated 23 January 2017. For avoidance of doubt, the securities of the Company are not listed on DSE owing to DSE having been de-recognised by SEBI.

ESCORTS KUBOTA LIMITED
(Formerly Escorts Limited)

Registered Office: 15/5, Mathura Road, Faridabad 121 003, India

Tel.: +91-129-2250222

E-mail: escortsgroup@escorts.co.in Website: www.escortsgroup.com

Corporate Identification Number L74899HR1944PLC039088



Escorts Kubota Limited

(Formerly Escorts Limited)

**Committed to
Spreading Prosperity,
Impacting Life.**



Certain statements in this document include forward-looking comments and information concerning the company's plans and projections for the future, including estimates and assumptions with respect to economic, political, technological, weather, market acceptance and other factors that impact our businesses and customers. Such forward-looking statements are subject to certain risks and uncertainties like regulatory changes, local political or economic developments, and many other factors that could cause our actual results to differ materially from those contemplated by the relevant forward-looking statements. Escorts Kubota Limited will not be in any way responsible for any action taken based on such statements and undertakes no obligation to publicly update these forward-looking statements to reflect subsequent events or circumstances.





Current Business Environment

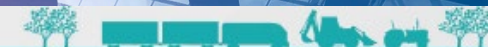



Highest **Inflation** in decades led to significant increase in Component & Logistics Cost





Pandemic has still not ended,
World has started reopening and recovering

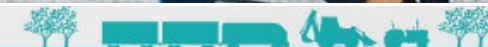



New Order of Doing Business

Cost Efficiency, Market Responsiveness & Digital



Food Security

The Biggest
Challenge
to Humanity





Business Continuity & Well Being

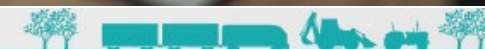



A Resilient Growth Story

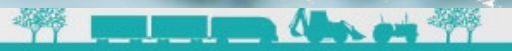



A close-up photograph showing several pairs of hands of different skin tones gently holding small green seedlings with dark soil. The focus is on the central seedling, with others in the foreground and background slightly blurred. The lighting is warm and soft, highlighting the texture of the soil and the vibrant green of the leaves.

Core Sector's Fundamentals

Government doubled Agri Budget & working to transform the Sector.
India has a huge upside in Agri Production.



Growth Potential

Domestic Industry to breach **1 million mark** & Exports will also grow.

Farm mechanization story yet to unfold with Farm Equipment.





Turning a new chapter

Institutionalizing Escorts Kubota Limited





Vision & Mid Term Business Plan



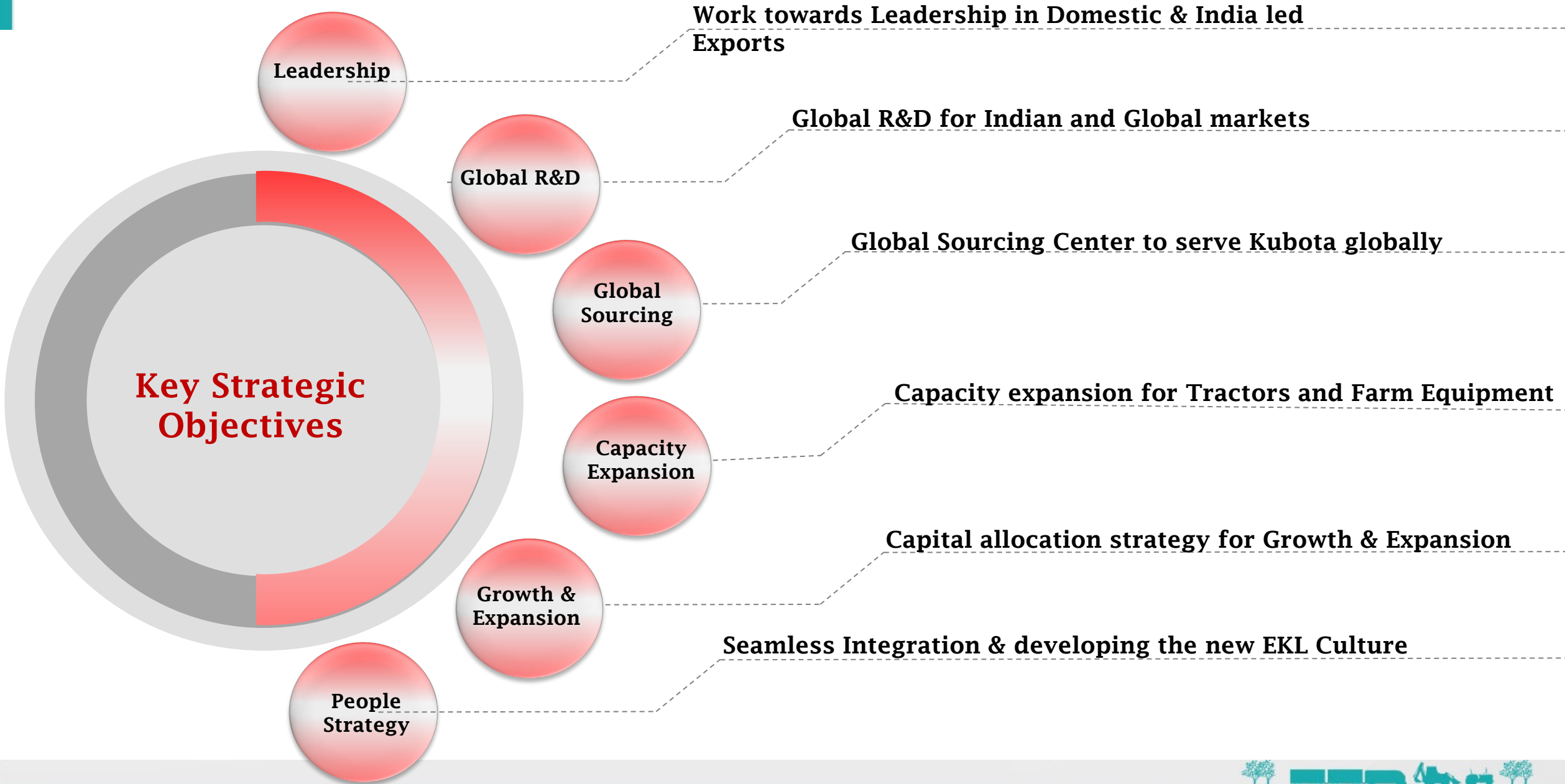

Gratitude to partnership



Yuichi Kitao
President and Representative
Director



Dai Watanabe
Director and Senior Managing
Executive Officer



Video Message from Kitao San, Kubota Corporation





Escorts Kubota Limited Video







Merger & Integration Plan*

Goal of making Escorts Kubota Limited the exclusive vehicle of business in India





Performance & Challenges

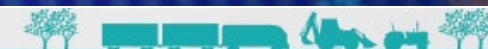

Group Financial Performance

TOTAL INCOME (₹. Cr.)

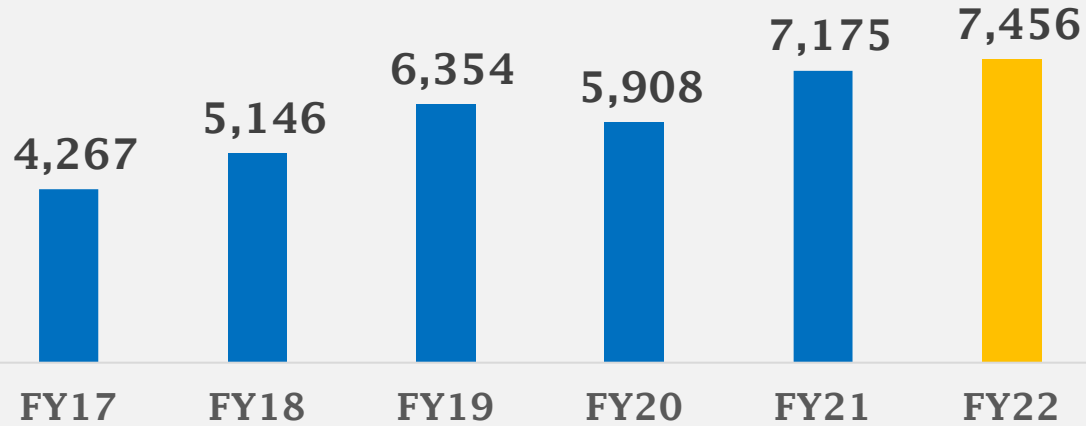

Material Cost %

Adverse commodity prices

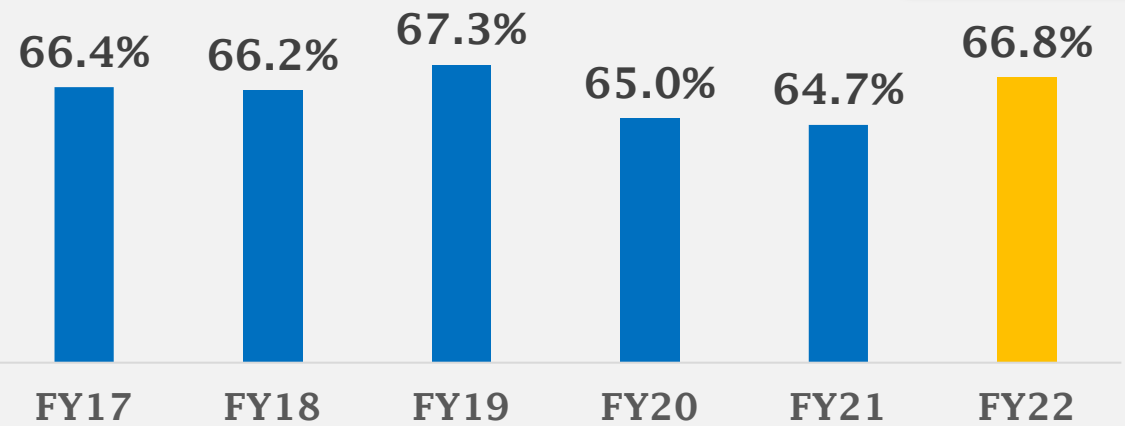

EBITDA (₹. Cr.)

%

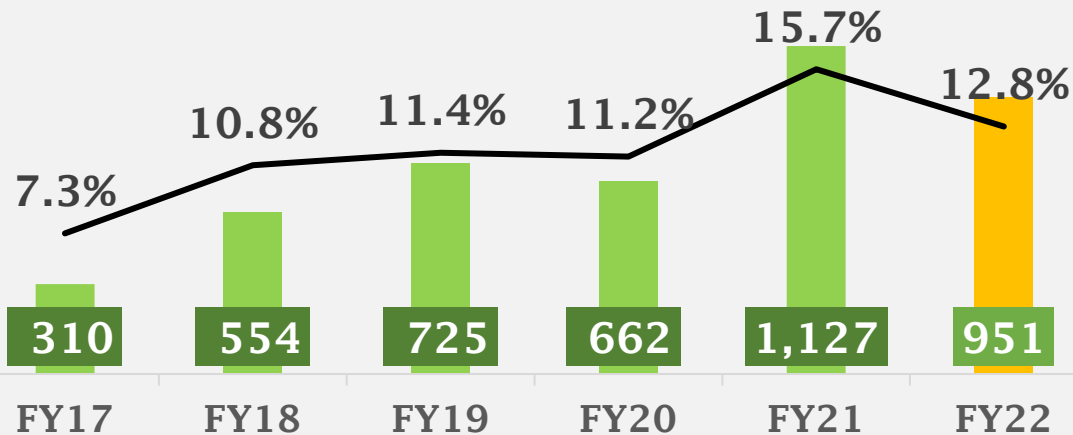

PAT (₹. Cr.)

%

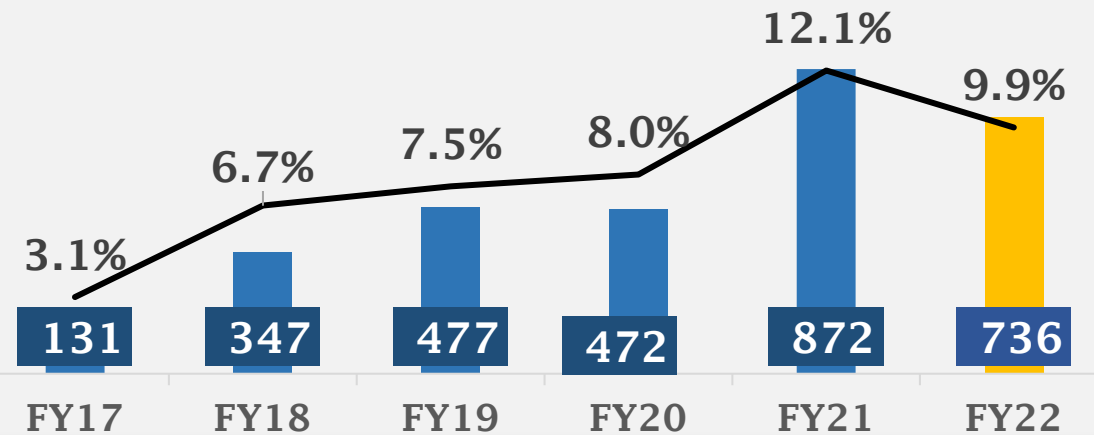

Recommended Total Dividend of 70% per Equity Share

Group Financial Performance

EPS (₹)

Standalone

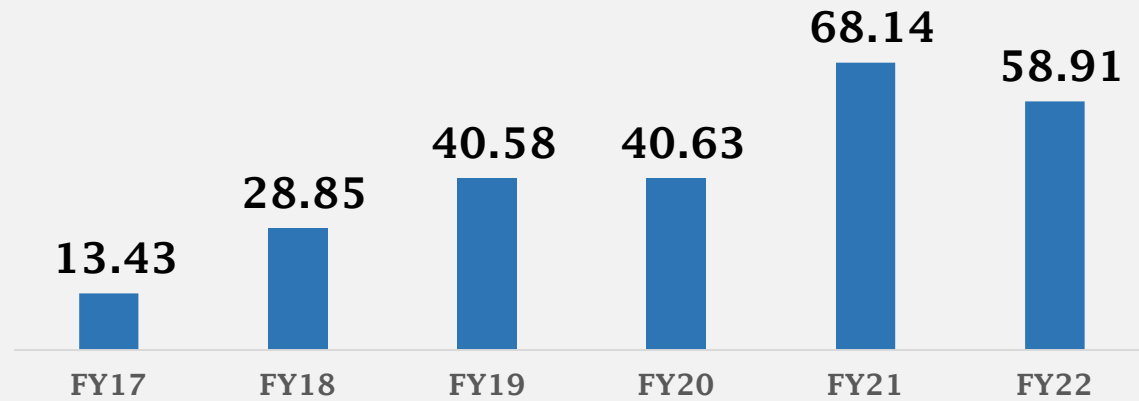

EPS (₹)

Consolidated

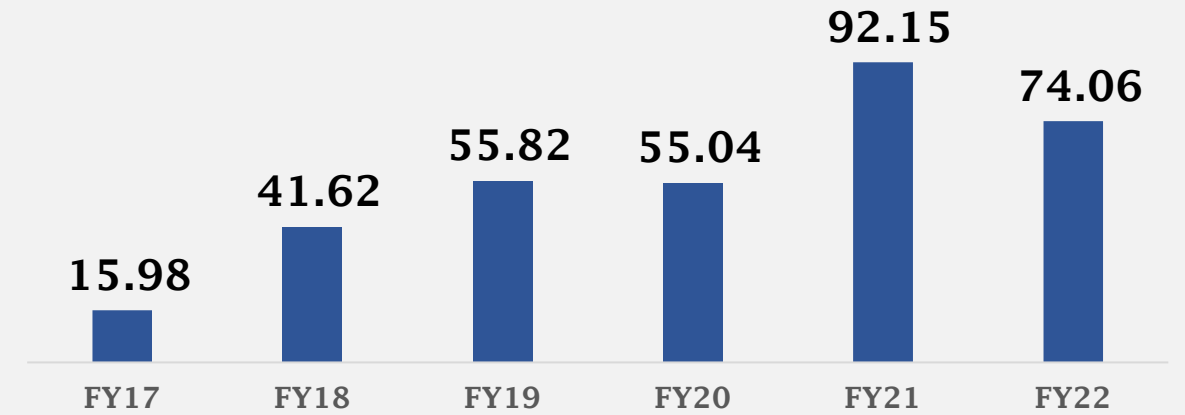

ROE

Consolidated %

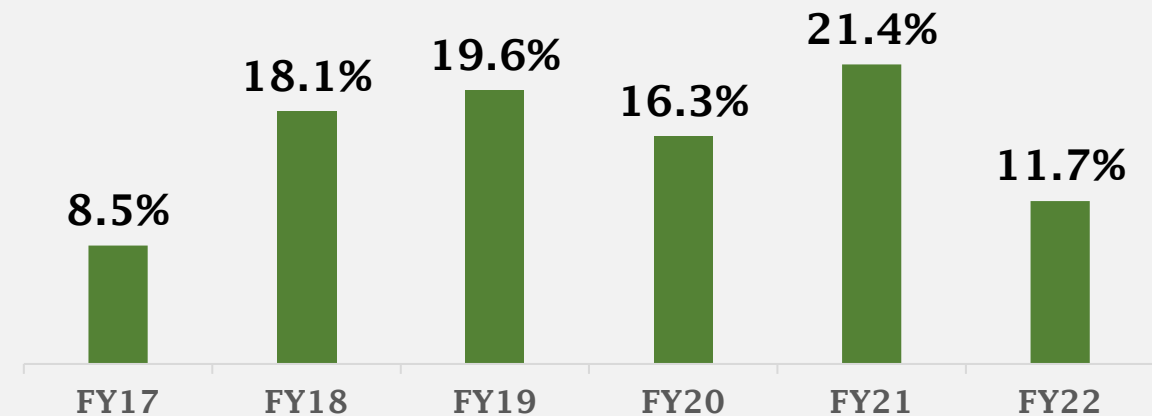

ROCE

Consolidated %

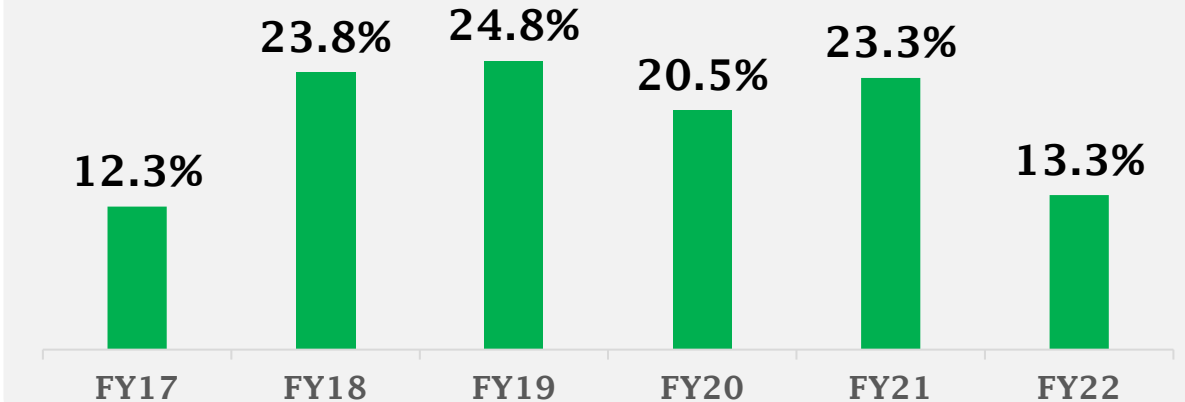

Agri Machinery



Powering The Dreams Of Farmer

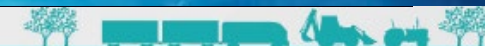

Agri Business

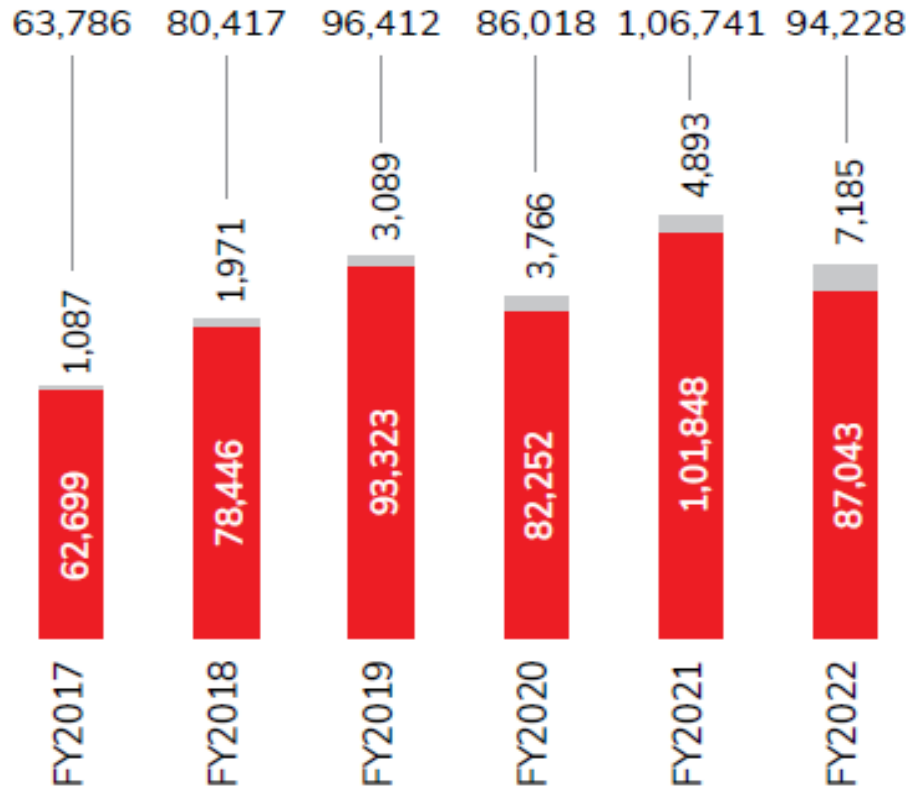

	Y-o-Y	5-year CAGR
■ Domestic	-14.5%	6.8%
■ Exports	46.8%	45.9%
Total	-11.7%	8.1%





New Products & Technology



Farmtrac NETS Series



Powertrac NEXT Series



Stage V Emission for Exports



Construction Equipment



**Building a
Better Tomorrow**

Preferred Partner In Nation Building

Construction Business

ECE VOLUMES

4.4% ↑ 5-year CAGR 5.2% ↑ y-o-y growth

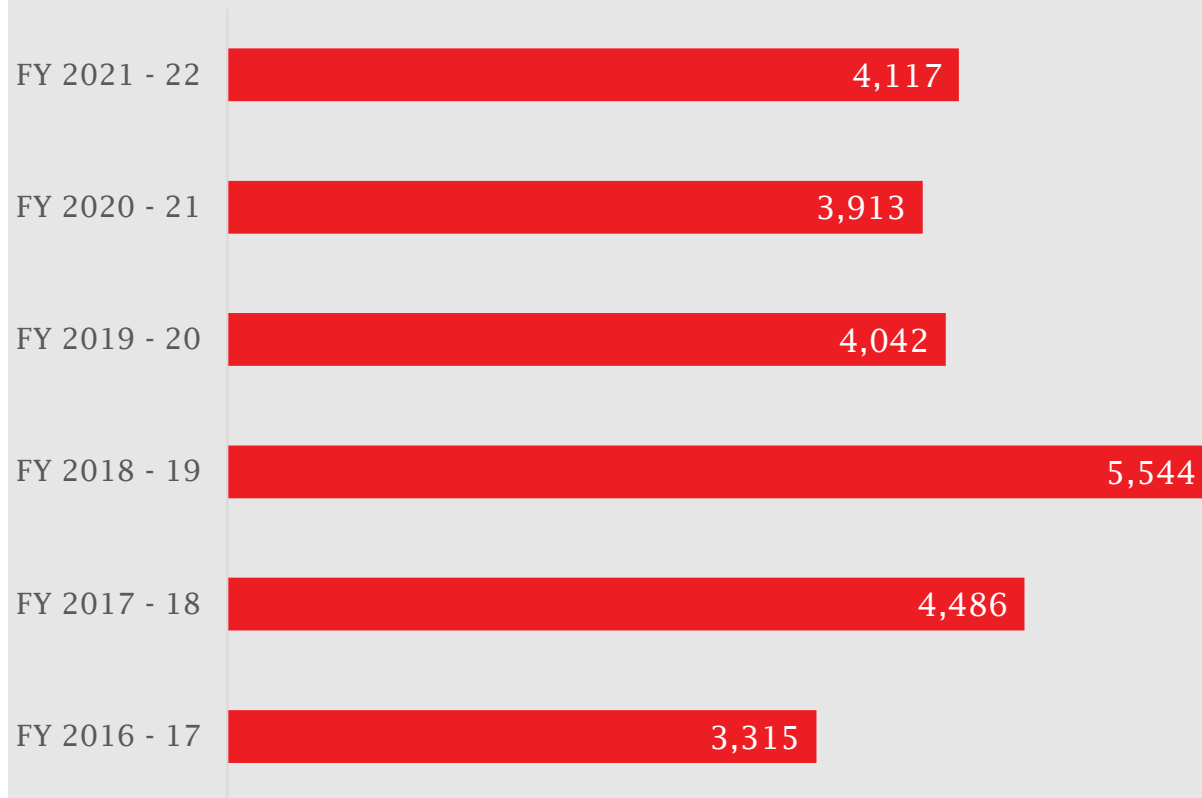

+59.2%
VOLUME GROWTH
(H1-FY22)

Served Industry Growth
+5.2% in H1-FY22



New Products & Technology



F20 Piling Master



New Products & Technology



New Products & Technology



**HD85
PLUS**



Railway Equipment Division



Mobility Solutions
Of the future

Ensuring Safety And Comfort In Rail Transport

Railway Equipment Division

RED Revenue (in ₹ Crores)

21.3% ↑ 5-year CAGR 32.8% ↑ y-o-y growth

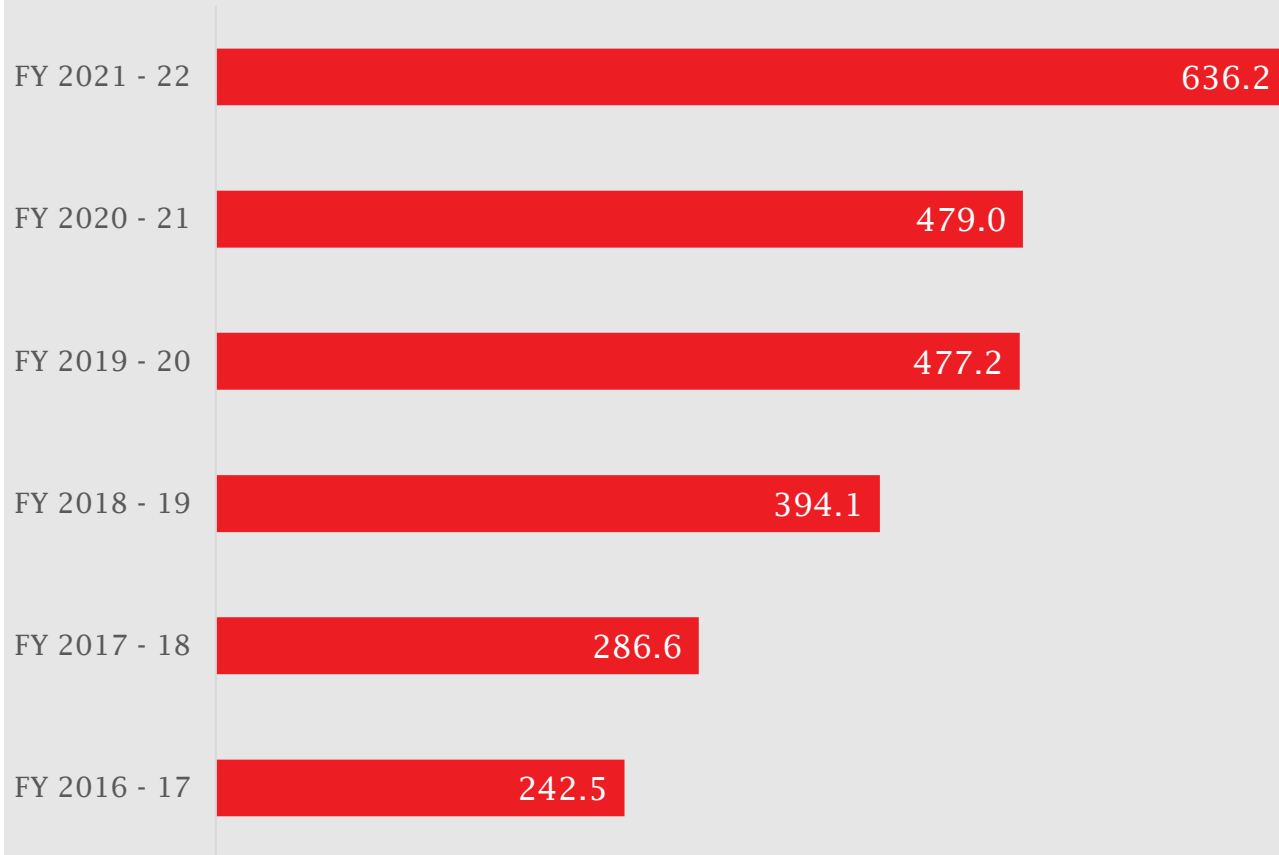

+32.8%

Sales Up in FY22 (Y-o-Y)

14.8%

EBIT For FY22



New Products & Technology



**Microprocessor Controlled Brake System
(EMCBS)**

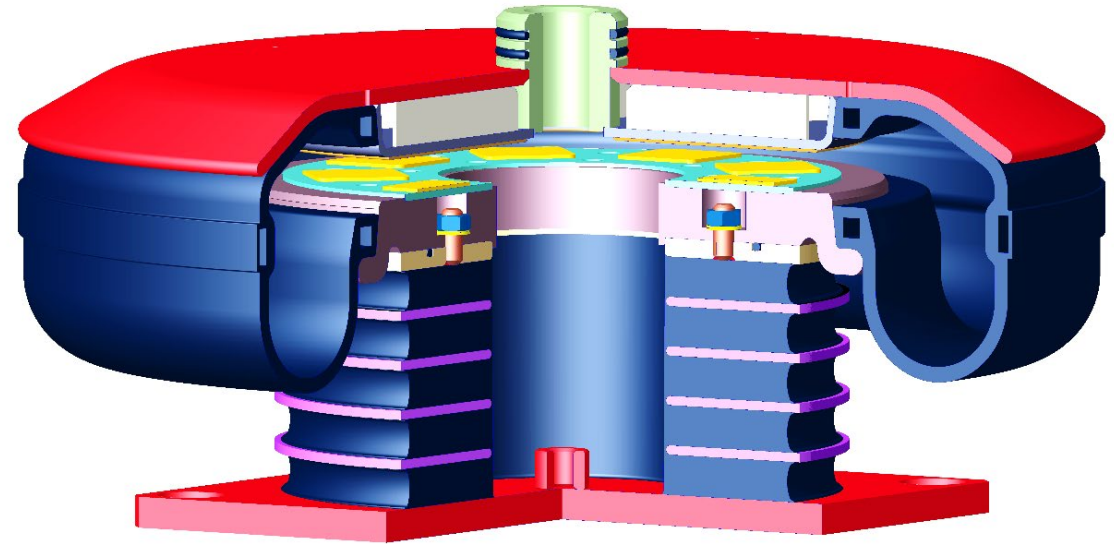

Air Spring



New Products & Technology

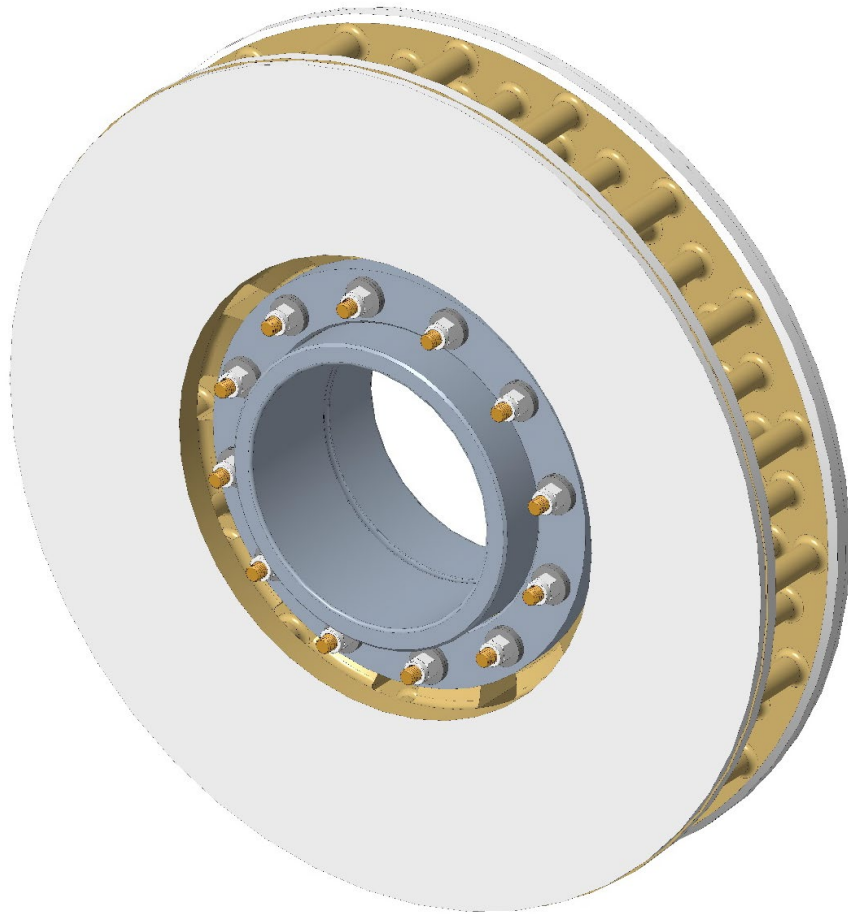

Brake Disc



Brake Pad





Going Forward

It may take some time to get back to normal margins level, the recovery will be gradual.





Key Focus Areas to Build New EKL



Brand Portfolio



Powertrac



Kubota



Farmtrac



Farm Mechanization



Boom Sprayer



Harvester

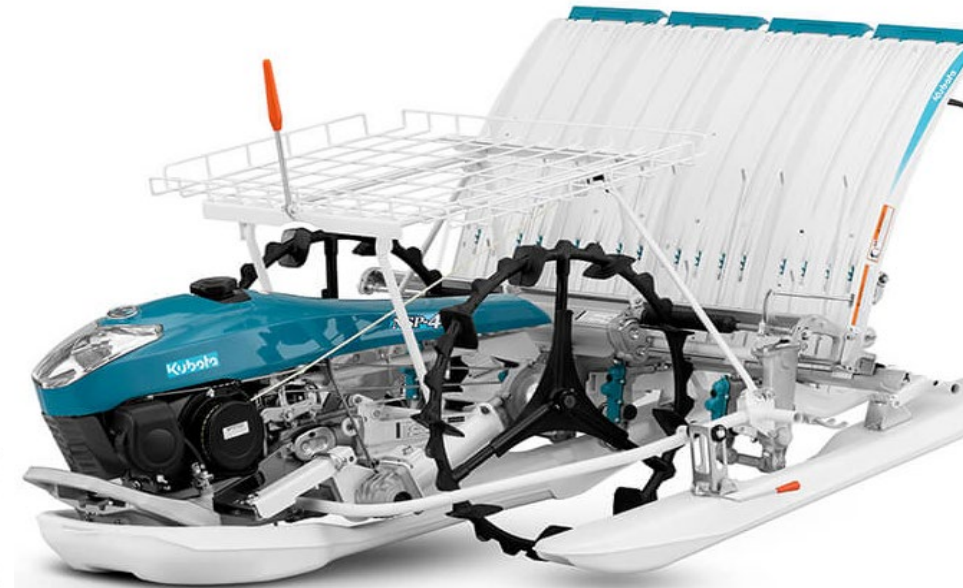

**Rice
Transplanters**



Rajan Nanda Innovation Lab (RNIL)

RNIL will closely work with Kubota's Global Innovation system and work on solving many problems of farming & other businesses.





Carbon Neutral Strategy

Focus on alternate **fuel technologies** will continue.

Expansion of **Electric Vehicle** portfolio.

FARMTRAC FT25-G

Image Courtesy Microsoft 365 Creative content



Culture & People Strategy

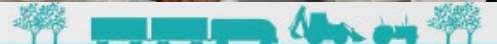
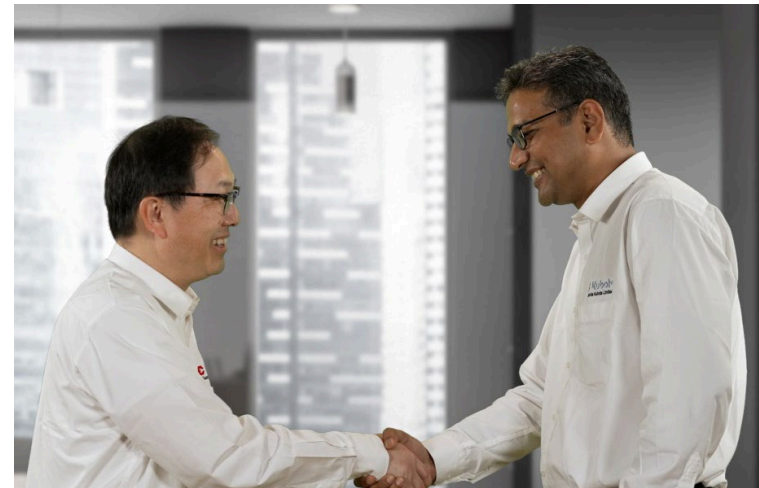
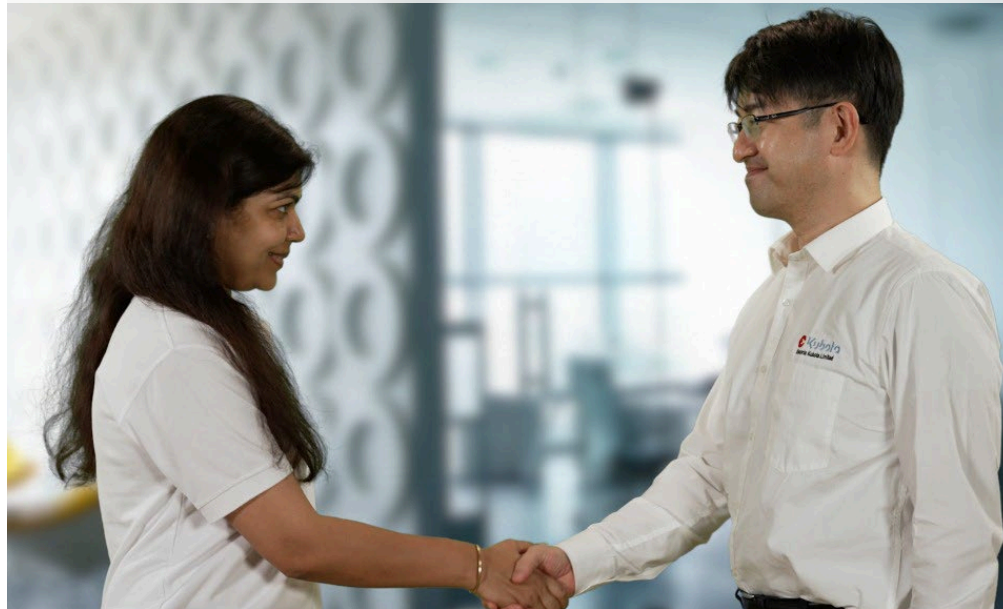
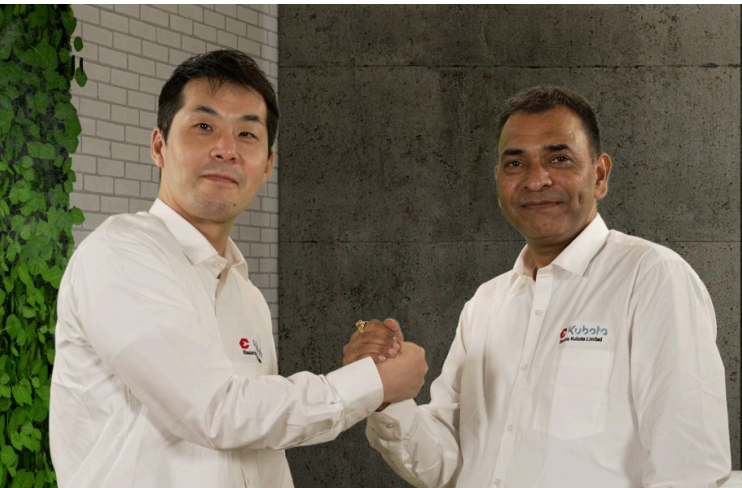



Culture & People Strategy





ESG & CSR Commitment



Escorts Announces Second Edition of Free Community COVID Vaccination Camp

COWINNER

जन साधारण में कोविड-19 वैक्सीन का महा अभियान

Milestone Achievement
51,000+
VACCINE DOSES
ADMINISTERED

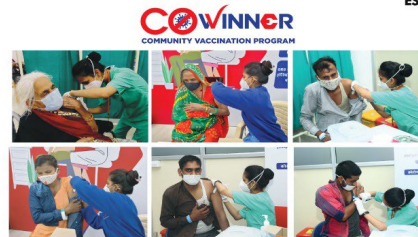

We are happy to announce that the COWINNER Community Vaccination Program, has crossed 51,000+ vaccine doses over last few months.

We extend our heartfelt gratitude to each one of you for your voluntary participation and reaching out to communities to spread the word and turning this idea into reality.

We would also like to acknowledge collaborative support received from District Administration and our healthcare partners – QAG Health City and Sarvodaya Health Care, Faridabad.

We are glad that as part of its Corporate Social Responsibility, Escorts contributed to the society by playing our part towards national mission of #VaccineForAll.



Escorts Kubota Limited



COWINNER

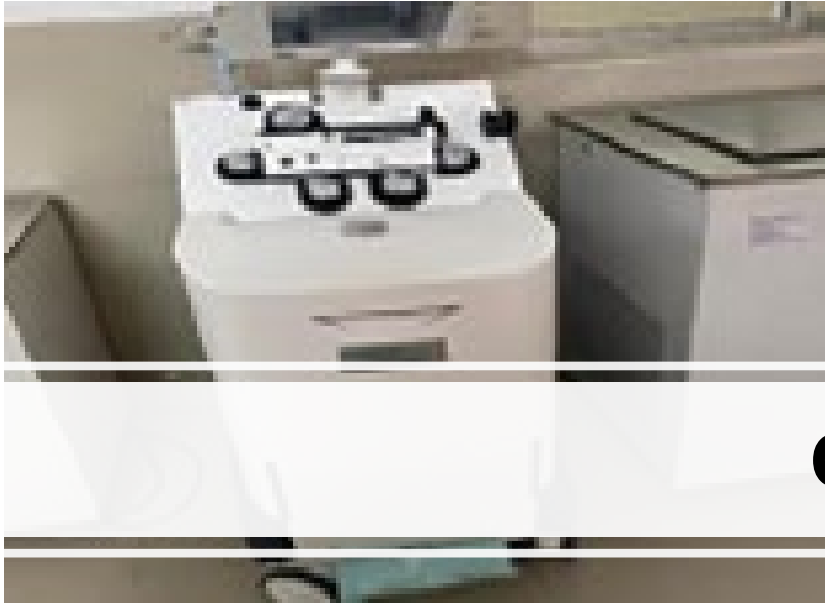

CSR





Planet & People at fore front





Escorts Advanced Institute of Farm Mechanization (EAFI)

Upliftment of marginal farming community through skill set building and knowledge transfer in the areas of farming methodology



Credit Rating



Thank You to the Board.

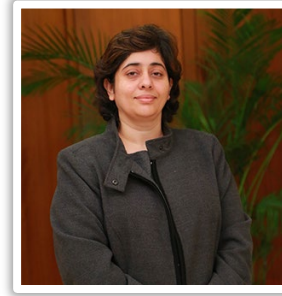

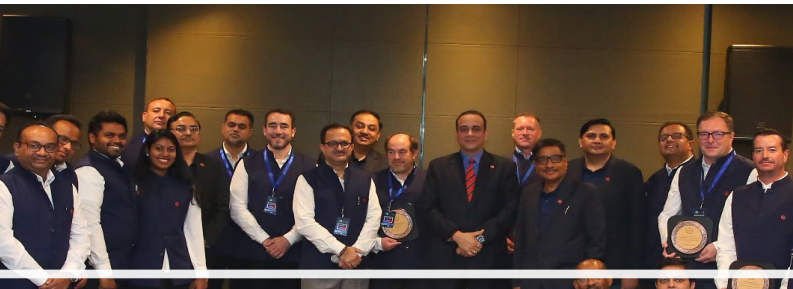



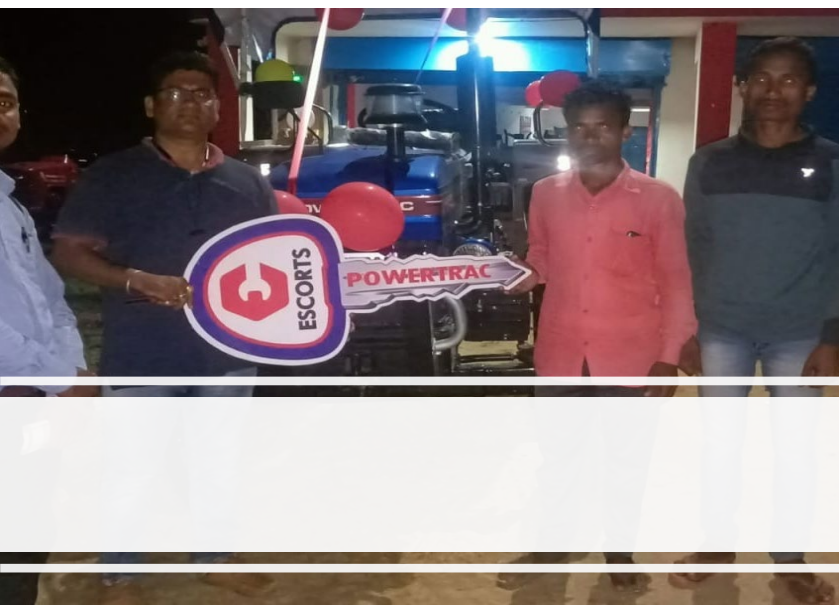

Customers





Escorts Kubota Limited



Vinaka Dankscheen Vinaka
 Kam Sah Hammida ڪام سه هاميڊا
 Maake Maake Maake
 Asante Asante Asante
 Shukria Shukria Shukria
 Dhanyavadagalu Dhanyavadagalu Dhanyavadagalu
 Manana Dankon Manana Dankon Manana Dankon
 감사합니다 감사합니다 감사합니다
 Dank Je Dank Je Dank Je
 Mauruuru Mauruuru Mauruuru
 Biyan Biyan Biyan
 Blagodaram Blagodaram Blagodaram
 Ngiyabonga Ngiyabonga Ngiyabonga
 Dziekuje Dziekuje Dziekuje
 Juspaxar Juspaxar Juspaxar
 Thank Thank Thank
 Arigato Arigato Arigato
 Chokrane Chokrane Chokrane
 Diolch i Chi Diolch i Chi Diolch i Chi
 Terima Kasih Terima Kasih Terima Kasih
 Taiku Taiku Taiku
 Tack Tack Tack
 Grazie Grazie Grazie
 Mochchakkeram Mochchakkeram Mochchakkeram
 Tingki Tingki Tingki
 Gratias Tibi Gratias Tibi Gratias Tibi
 Obrigado Obrigado Obrigado
 ありがとうございます ありがとうございます ありがとうございます
 Ua Tsaug Rau Koj Ua Tsaug Rau Koj Ua Tsaug Rau Koj
 Bedankt Bedankt Bedankt
 Dakujem Dakujem Dakujem
 Grazas Grazas Grazas
 धन्यवाद धन्यवाद धन्यवाद
 cảm ơn bạn cảm ơn bạn cảm ơn bạn
 Dėkuji Dėkuji Dėkuji
 Nirringrazzjak Nirringrazzjak Nirringrazzjak
 Hvala Hvala Hvala
 Di Ou Mési Di Ou Mési Di Ou Mési
 Suksama Suksama Suksama
 Welalin Welalin Welalin
 Kia Ora Kia Ora Kia Ora
 Kop Khun Khap Kop Khun Khap Kop Khun Khap
 Matur Nuwun Matur Nuwun Matur Nuwun
 谢谢 谢谢 谢谢
 xвала xвала xвала
 Danke Danke Danke
 Merci Merci Merci
 Salamat Salamat Salamat
 Raibh Maith Agat Raibh Maith Agat Raibh Maith Agat
 Agat Agat Agat
 Djere Dieuf Djere Dieuf Djere Dieuf
 Eskerrik Asko Eskerrik Asko Eskerrik Asko
 Najis Tuke Najis Tuke Najis Tuke

- **EAM** - Escorts Agri Machinery
- **ECE** - Escorts Construction Equipment
- **RED** - Railway Equipment Division
- **FY** - Fiscal Year represents the 12 months period from 1st April to 31st March.
- **FY2021** - Fiscal Year represents the 12 months period from 1st April 2020 to 31st March 2021
- **FY2022** - Fiscal Year represents the 12 months period from 1st April 2021 to 31st March 2022
- **QoQ** - Represents Quarter on Quarter
- **YoY** - Represents Year on Year
- **LY** - Represents Last Year
- **CY** - Represents Current Year
- **BHL** - Backhoe Loader
- **IndAS** - - Indian Accounting Standards
- **NPD** - New Product Developed
- **PnC** - Pick & Carry Crane



Contact Details

Investor Relations
Escorts Kubota Limited
(CIN: L74899HR1944PLC039088)
Corporate Centre
15/5 Mathura Road
Faridabad - 121003
Phone: +91 129 2250222
www.escortsgroup.com
investorrelation@escorts.co.in

