



CAPTAIN PIPES LTD.

Regd. Office & Works : Survey No. 257, Plot No. 23 to 28, N.H. No. 27, SHAPAR (Veraval)
Dist. Rajkot (Gujarat) INDIA. Phone : +91 2827-252410, Mobile : +91 99090 29066
website : www.captainpipes.com | e-mail : info@captainpipes.com
CIN. : L25191GJ2010PLC059094

22ND MAY, 2024

To,
General Manager,
Listing Department,
The Bombay Stock Exchange Limited,
P. J. Towers, Dalal Street,
Mumbai – 400 001

Scrip Name: CAPTAIN PIPES LTD.

Scrip No. : 538817

Subject: INVESTOR PRESENTATION FOR Q4-FY24.

Dear Sir/Madam,

Pursuant to provisions of Regulation 30 of SEBI (Listing Obligations and Disclosure Requirements) Regulations, 2015, attached herewith investor presentation for the quarter and year ended on March 31, 2024 i.e. Q4-FY24.

This is for your record and information.

FOR, CAPTAIN PIPES LIMITED

Kantilal
Manilal Gediya

Digitally signed by Kantilal Manilal Gediya
DN: cn=Kantilal Manilal Gediya, o=CAPTAIN PIPES LTD., email=Kantilal.Manilal.Gediya@captainpipes.com, postalCode=360001, serialNumber=1, c=IN
Reason: I am the author of this document
Date: 2024.05.22 11:47:46+0530
Foxit PDF Reader Version: 12.0.2

**MR. KANTILAL M. GEDIA
(WHOLETIME DIRECTOR)
DIN: 00127949**



CAPTAIN PIPES LTD.

Plumbing | Agriculture | Drainage

Investor Presentation Q4FY24



TABLE OF CONTENT

1	About Us	9	Business Segments
2	Key Strengths	10	Product Portfolio
4	Vision	11	Marketing Communications
5	Highlights	12	Company Financials & Summary
6	Manufacturing Facility	13	Management Comments & Guidance
7	Growth Funnel		
8	Industry Growth Drivers		



ABOUT US

- Captain Pipes Limited (CPPL) has established itself as one of the leading brands in the PVC Pipes industry with its excellent quality products and strong distribution network.
- CPPL has a complete range of PVC Pipes and Fittings for application in Agriculture and Plumbing.
- The company has marketing and distribution network across multiple states in India and also exports to many countries.

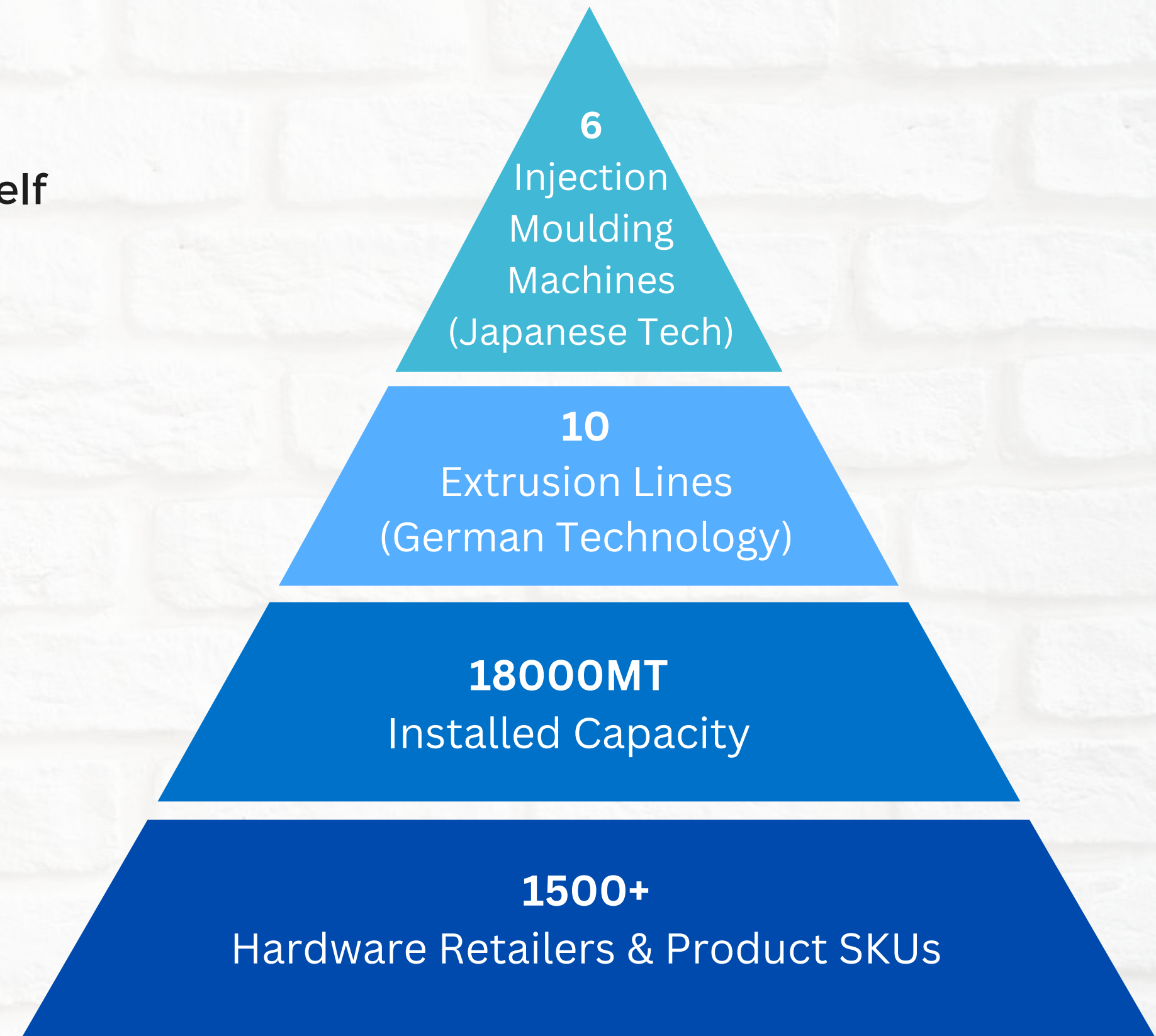

KEY STRENGTHS



Optimal Utilization of Resources



Diversified Product Portfolio (1500+ SKUs)

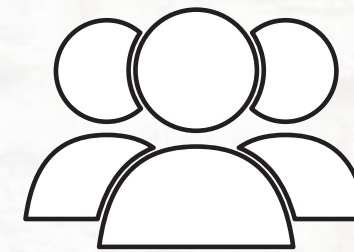

Experienced Management Team



Robust & Scalable Business Model

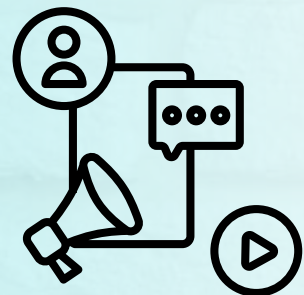

Strong Marketing & Distribution Network



Strong Geographical Presence in Both Domestic & Export Markets

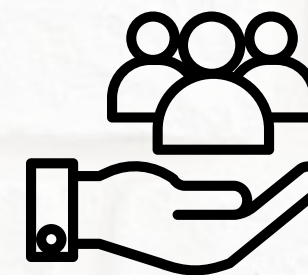

Providing Customized Value Added Services

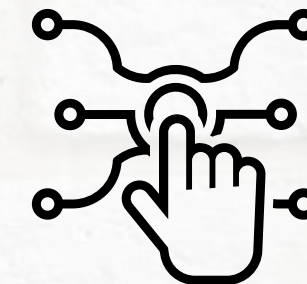

Adoption of Technology in CRM & Sales Automation

VISION

We firmly believe that our success depends on our valuable customers and members of our company. We strive to create maximum value for our customers by providing them the most innovative and quality products for their needs. We always create an environment of trust, respect and healthy relationship within our company campus. With this emphasis on our customers and members of our company we wish to make "**CAPTAIN**" the most trusted brand in domestic and international market.



Q4FY24 HIGHLIGHTS

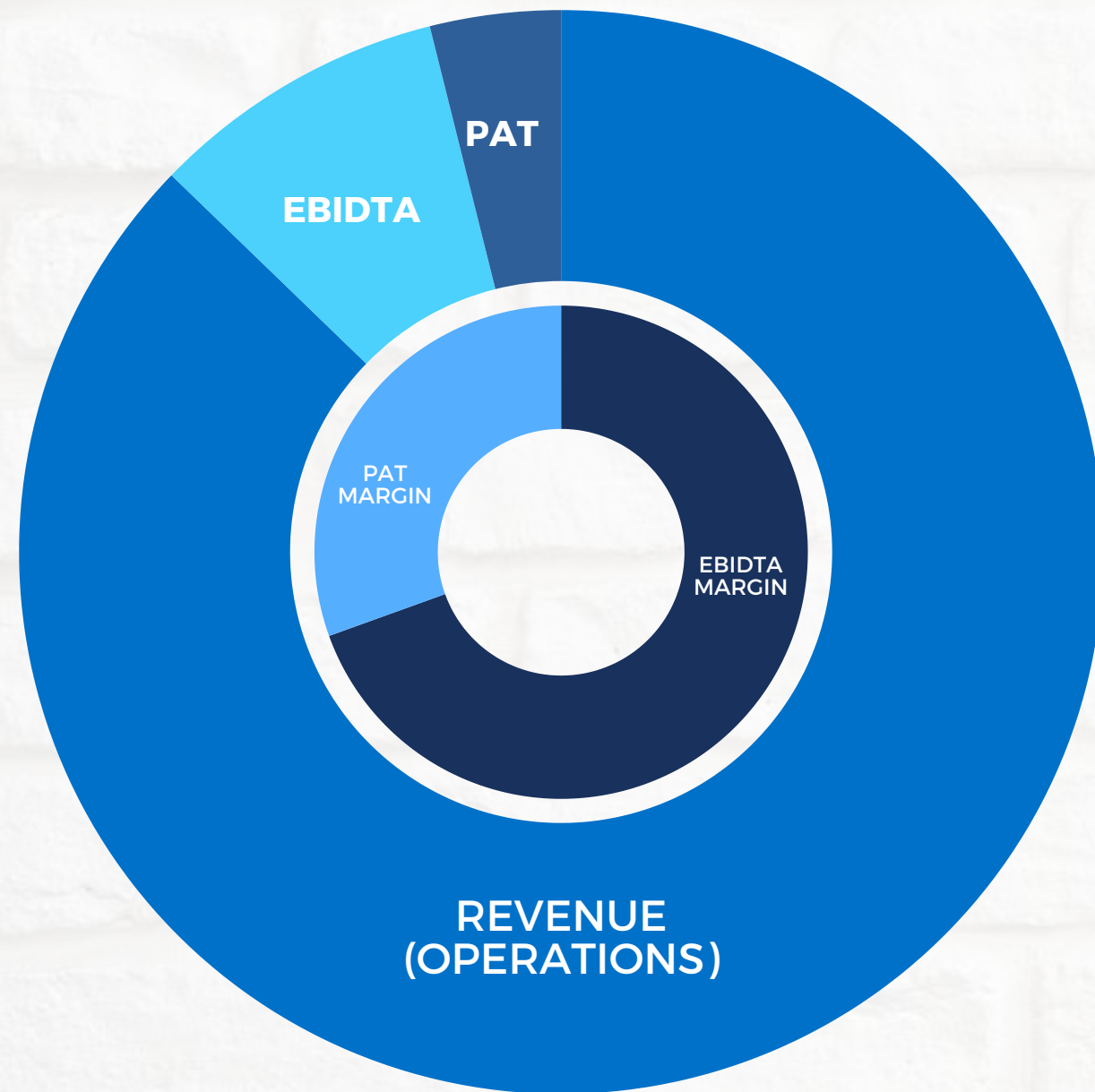

Revenue (Operations)	INR 2026 Lakhs
EBIDTA	INR 206 Lakhs
EBIDTA Margin	10.18%
PAT	INR 90 Lakhs
PAT Margin	4.47%

MANUFACTURING FACILITY

CPPL has set up their modern plant at National High-Way 27 at Shapar (Veraval) near Rajkot, Gujarat.

Working along with the growing market demand, it is fully equipped with hi-tech machinery and tools, with extrusion and injection moulding machines of German and Japanese technology, that are must for quality production.

CPPL is a client-centric organization and strives to meet the exact requirements of their clients. This is why, we also custom design their range as per the specifications of their clients.

We have been able to garner a huge client base in the global market due to our quality range and their ability to provide bulk requirements for their valued clients.

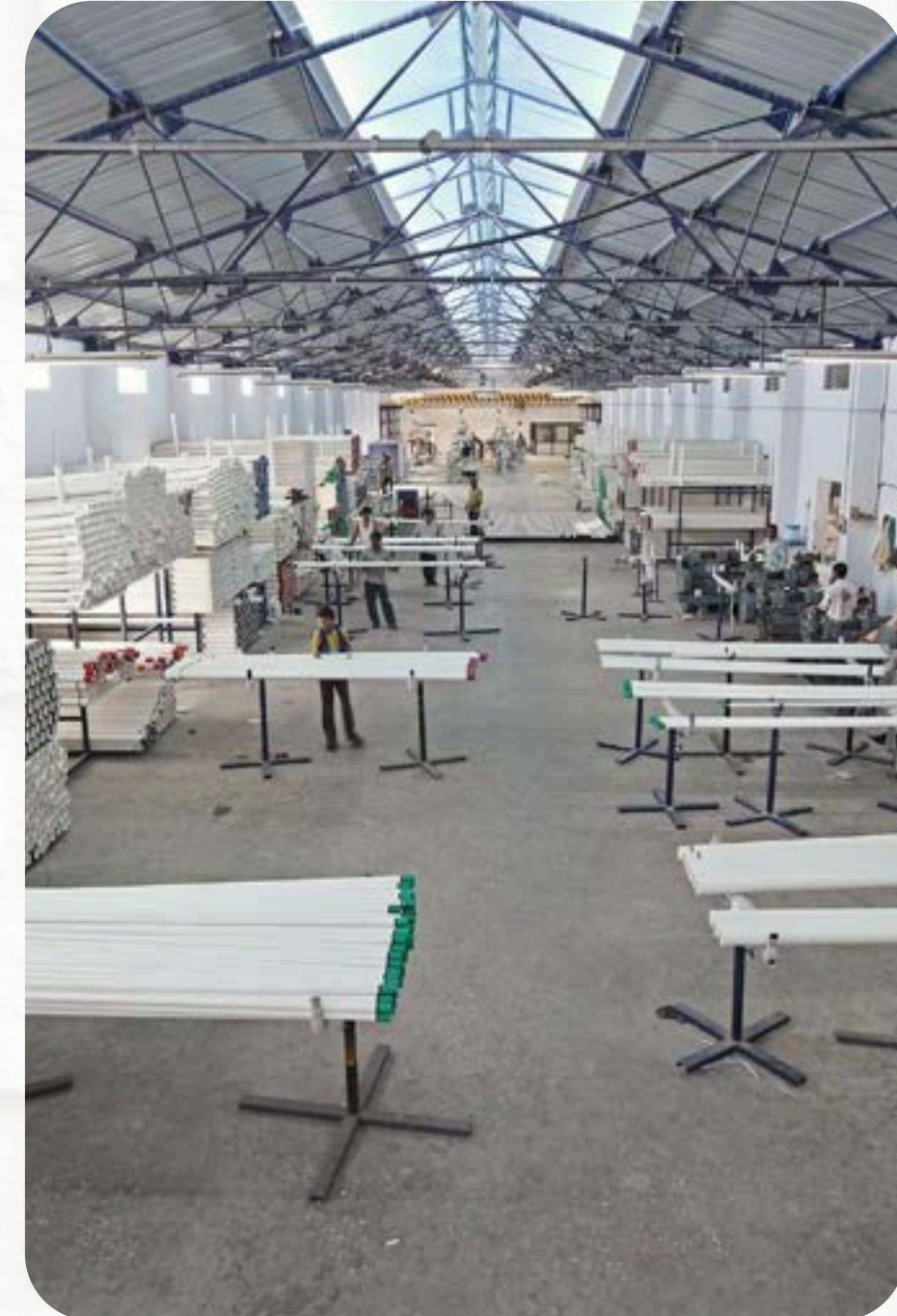

UPCOMING GREENFIELD PLANT

CPPL will set up greenfield manufacturing plant in Ahmedabad. The company has acquired 6 adjacent industrial plots totaling to **38054 Sq Mtrs.**

First Phase Key Metrics:

Total Investment: INR 25 Crore (Funded via Internal Accruals and bank financing)

Total Capacity: 20000 MT

Estimated Production Timeline: December 2024

Total land is more than 6 times the land of the existing plant at Rajkot and thus available for further expansion in future.



UPCOMING GREENFIELD PLANT

Currently in process of building factory shed and other amenities

Total Constructed Area will be **9000 Sq Mt**

Aatmanirbar Gujarat Schemes Applicable to Captain Pipes:

Interest Subsidy @ 5% on Term Loan with the maximum amount of Rs. 25 Lakhs per annum for a period of 5 years.

Net SGST Reimbursement - 80% of SGST for 10 years up to 5% of eFCI (Eligible Fixed Capital Investment) p.a.

EPF Reimbursement - reimbursement of employer's contribution under Employees' Provident Fund (EPF) made by them for their new employees working in Gujarat for 10 years from DoCP, subject to certain criteria.



USING WORLD CLASS EQUIPMENT

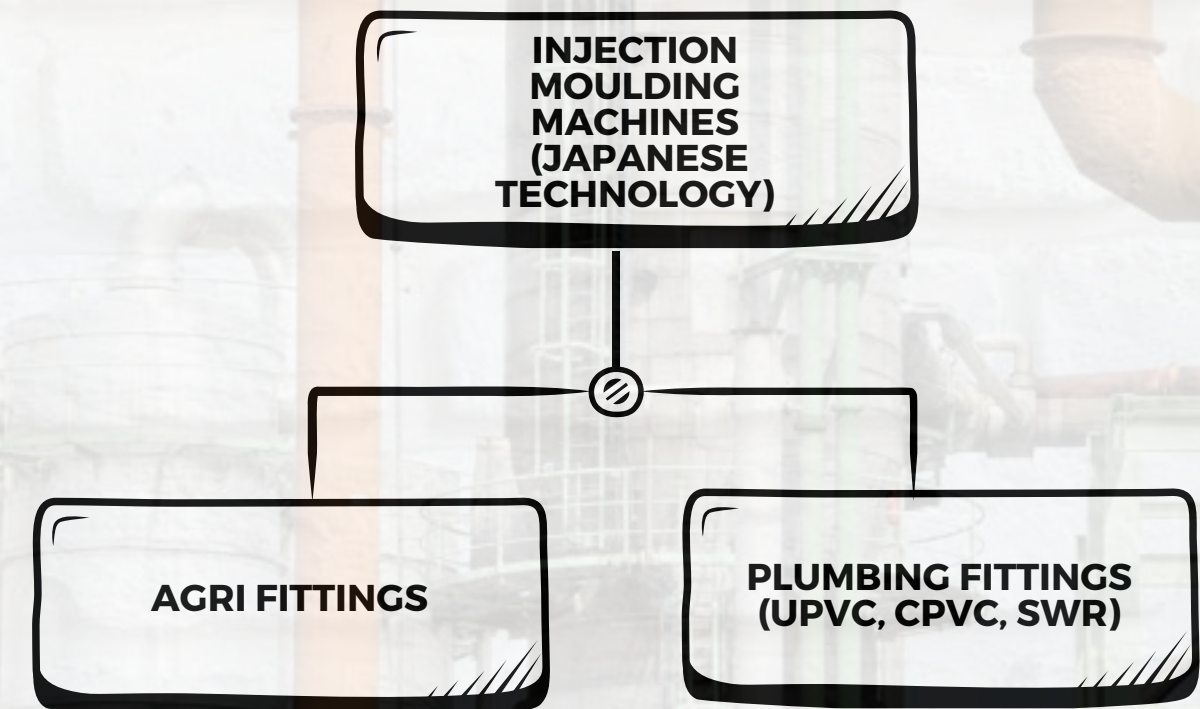
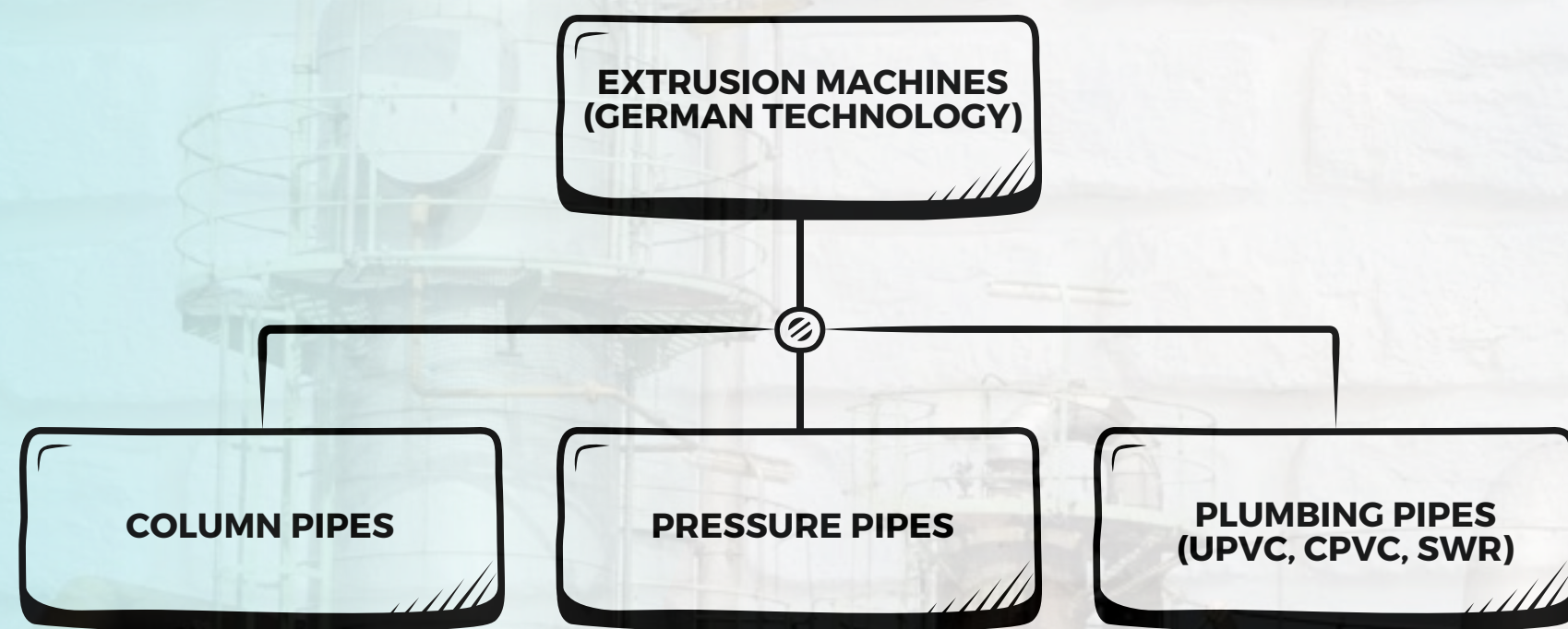

GROWTH FUNNEL

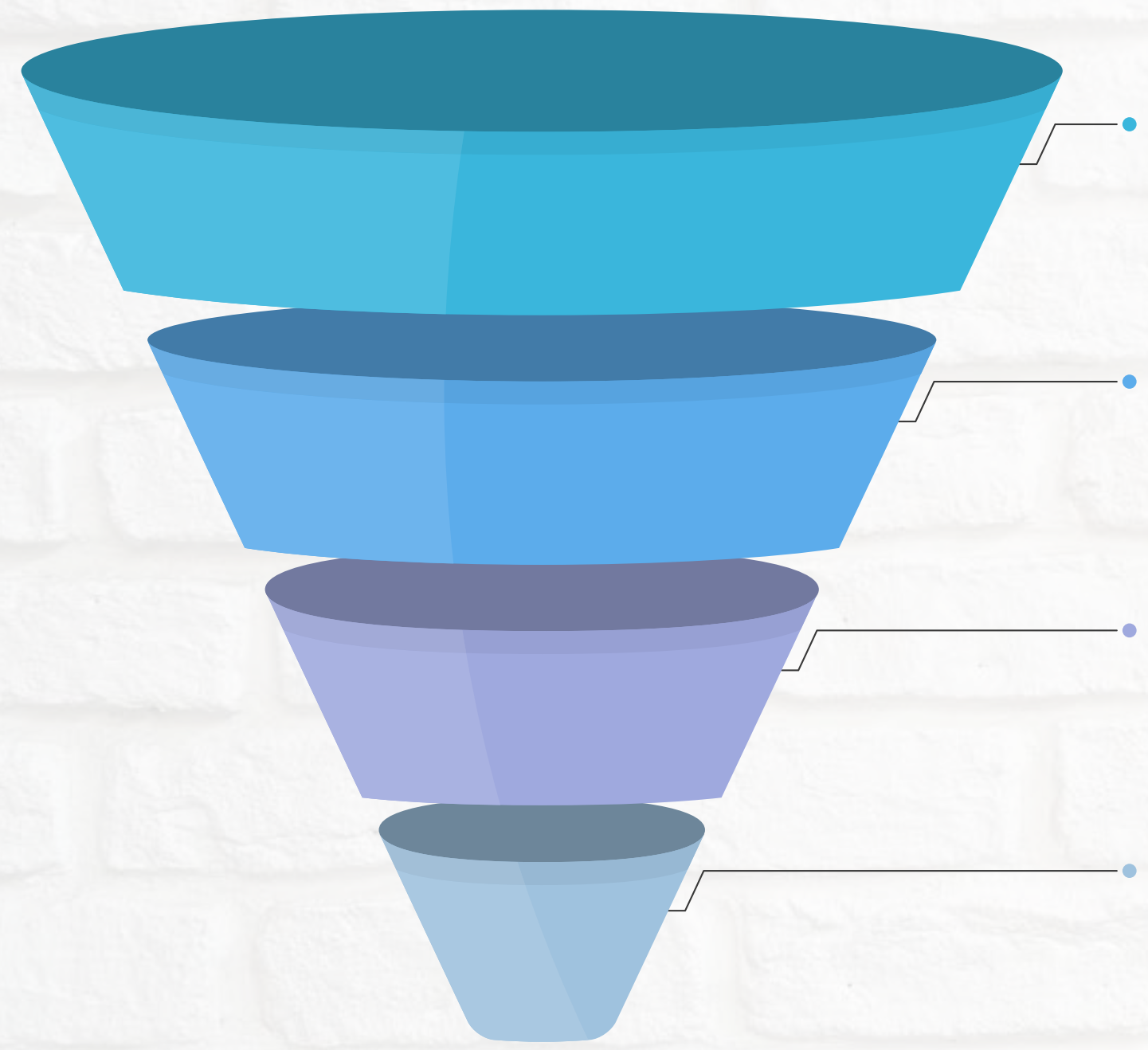

• Increase spend on marketing to increase brand strength and improve ASP in areas with strong presence

• Increase mix of high margin products in overall sales. (Column Pipes, Fittings, Plumbing)

• Network expansion within and outside the country.

• Expecting better utilization of the capacity, thereby improving the bottom line



MANAGEMENT OVERVIEW



RAMESH KHICHADIA
CHAIRMAN

In 1997, Mr. Ramesh Khichadia embarked on a visionary journey, laying the foundation for what would later evolve into the renowned Captain Group. He is an expert in the field of Irrigation business, with 30+ years of experience.

An alumnus of Gujarat Agriculture University, he holds a distinguished B. Tech degree in Agriculture Engineering.

With an illustrious career, he has honed an unparalleled expertise in the domain of Irrigation, garnering invaluable insights that continue to guide the company towards excellence.



GOPAL KHICHADIA
MANAGING DIRECTOR

As a pivotal member of our management team, Mr. Gopal Khichadia brings a wealth of knowledge and expertise that has played a transformative role in the growth and success of our company.

He is an esteemed industry veteran, with 20+ years of experience.

His approach to leadership fosters a culture of collaboration, creativity, and continuous improvement within our organization.

His extensive experience and insights into the PVC pipes industry equips the company with a competitive advantage.



RITESH KHICHADIA
GROUP COMPANY
DIRECTOR

Mr. Ritesh Khichadia is a highly accomplished and dynamic member of our management team.

He holds a BTech degree from the prestigious IIT Bombay, as well as a PGDM from the renowned IIM Lucknow.

His exceptional educational qualifications have paved the way for a career marked by remarkable achievements and strategic insights.

Before joining our organization, he gained valuable experience and exposure in the financial realm, where he served as an investment banker and M&A consultant for two years.

INDUSTRY GROWTH DRIVERS

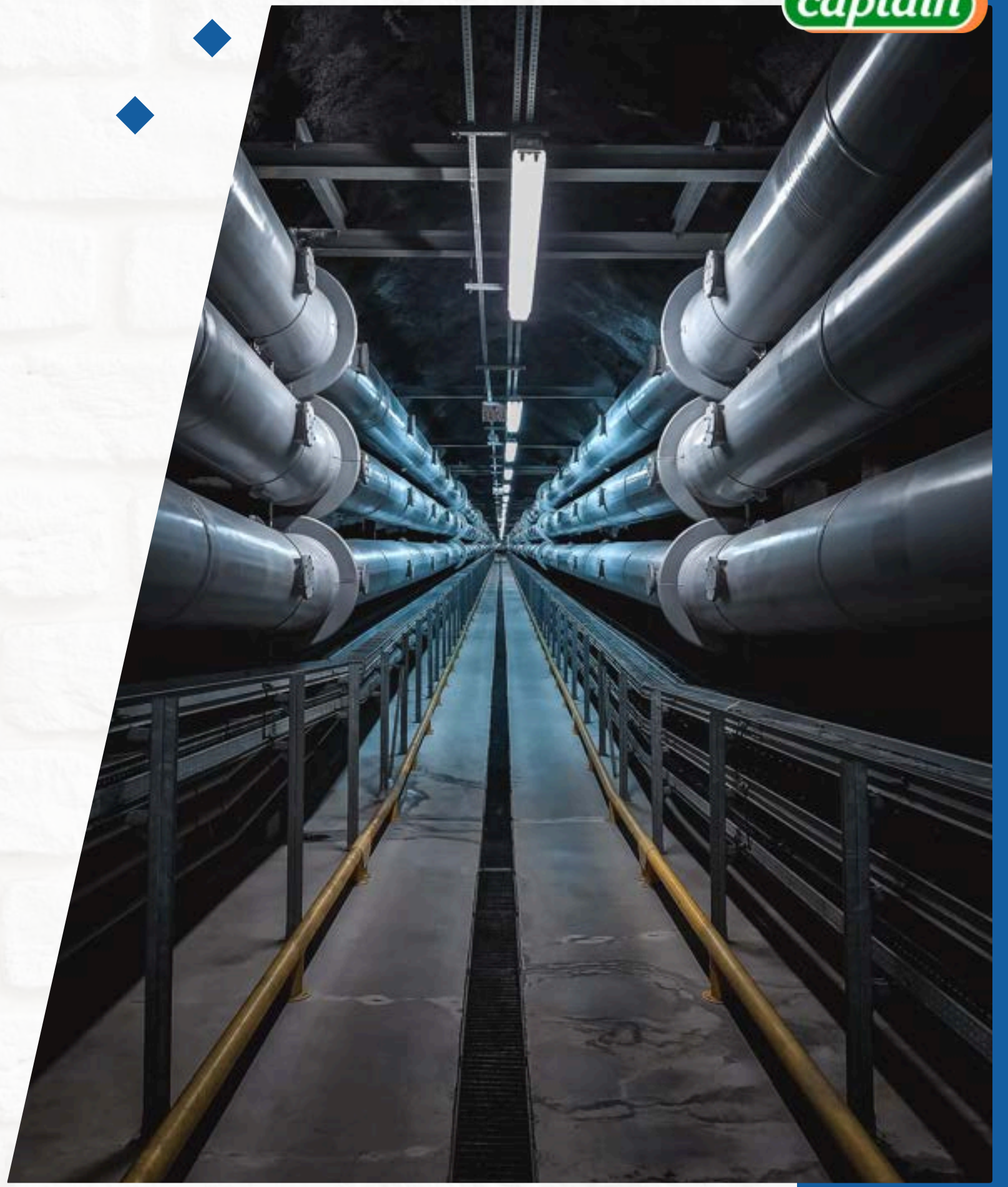

DEMAND FOR BUILDING MATERIALS

Demand for home building materials such as pipe & fittings, sanitaryware & faucets, are correlated to real estate market's growth. Plastic pipe sector is expected to deliver healthy growth over long-term.



ABILITY TO HANDLE FLUCTUATIONS IN RM PRICES

Organized players like us are well placed to handle fluctuations in PVC resin prices (main raw material) have gained significant market share. Positive volume growth on account of healthy demand & traction in real estate and construction activity, despite fluctuation in realizations.

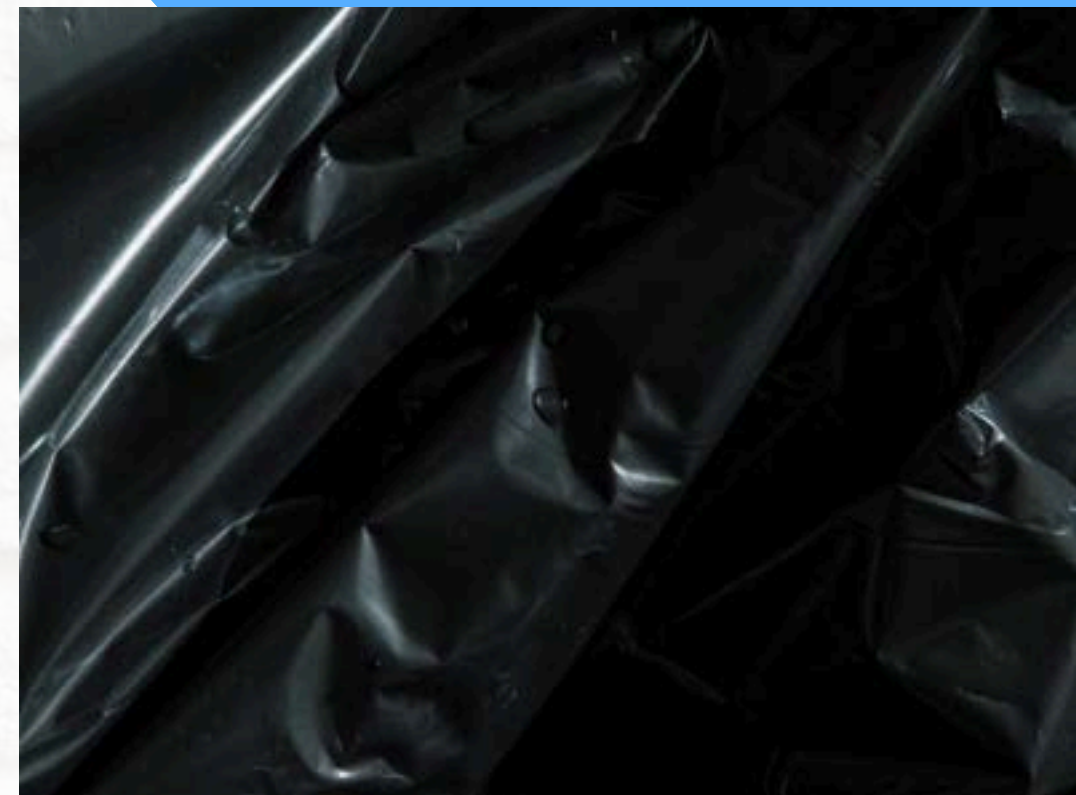
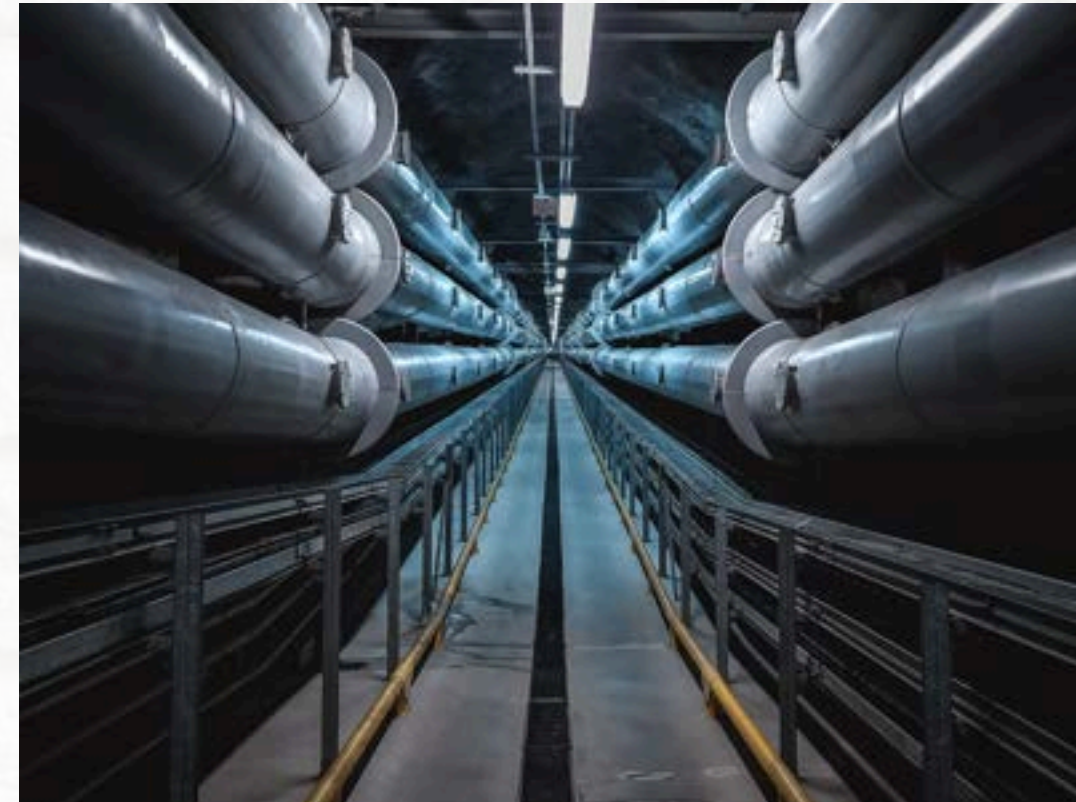

FASTEST GROWING SEGMENT IN BUILDING MATERIALS

The market for plastic pipes is valued at approximately Rs. 400bn, with organized players accounting for ~67% of the market. 50-55% of the industry's demand is accounted by plumbing pipes used in residential and commercial real estate.

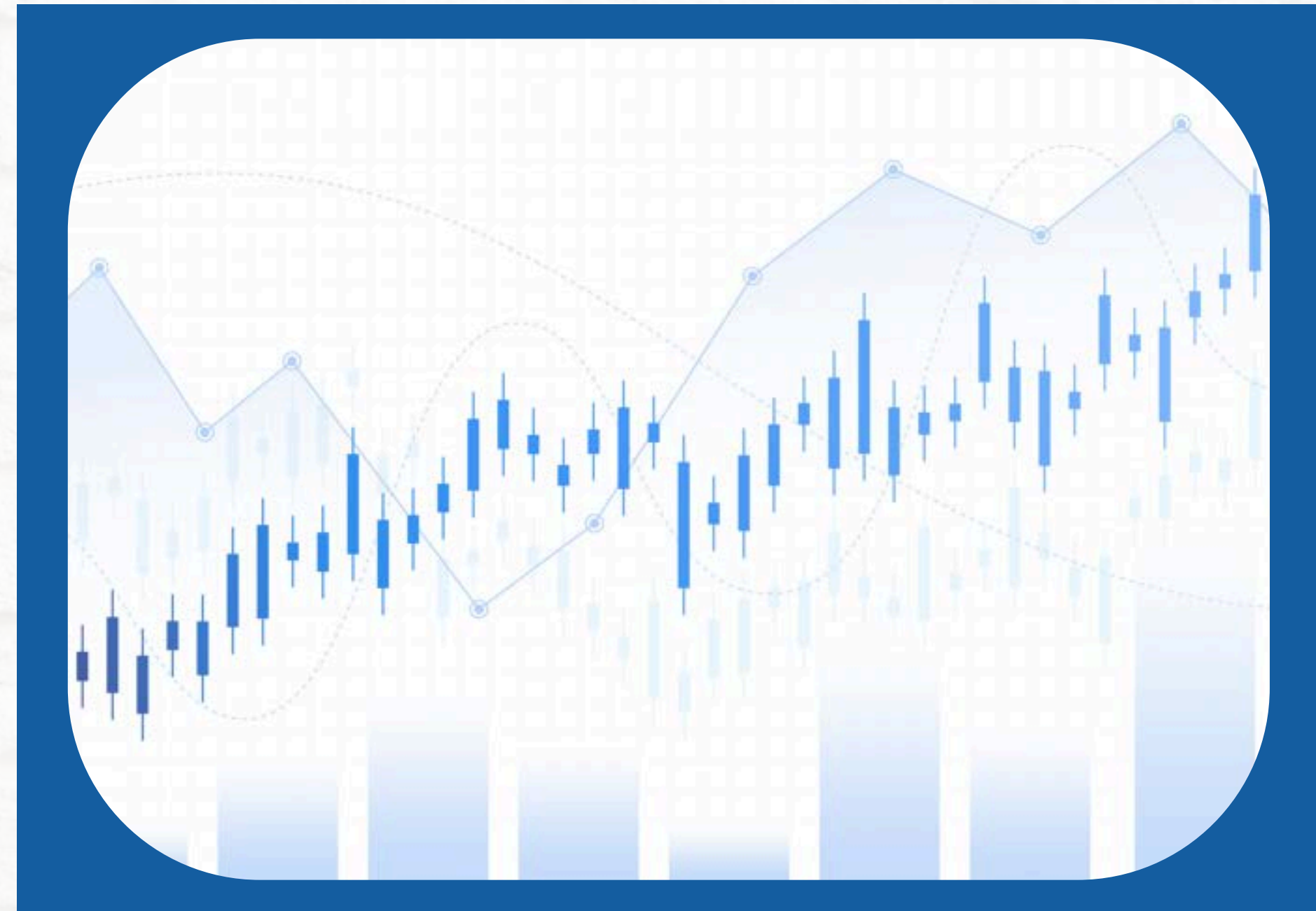

GOVERNMENT SUPPORT: JAL JEEVAN MISSION

The Government of India initiated Jal Jeevan Mission to assist, empower and facilitate rural communities. With government spending towards vital sectors, such as pipes, expected to rise, the pipes sectors is poised to record healthy growth.



MARKET HIGHLIGHTS

Types of Pipes	Industry Size (FY21) INR BN	FY20-24 (CAGR)	Application
uPVC	254	8-9%	<ul style="list-style-type: none"> • Irrigation • Cold Water Plumbing • Drainage
CPVC	65	15-17%	<ul style="list-style-type: none"> • Hot & Cold-Water System • Industrial Applications
HDPE / DWC Pipes	60	10-11%	<ul style="list-style-type: none"> • Underground Drainage Structure • WSS Solid Structure
PPR Pipes	21	6-7%	<ul style="list-style-type: none"> • Hot & Cold Water Systems • Industrial Applications
Composite Pipes	NA		<ul style="list-style-type: none"> • Hot & Cold Water Systems • Industrial Applications • Gas Pipeline

INDUSTRY BREAKUP

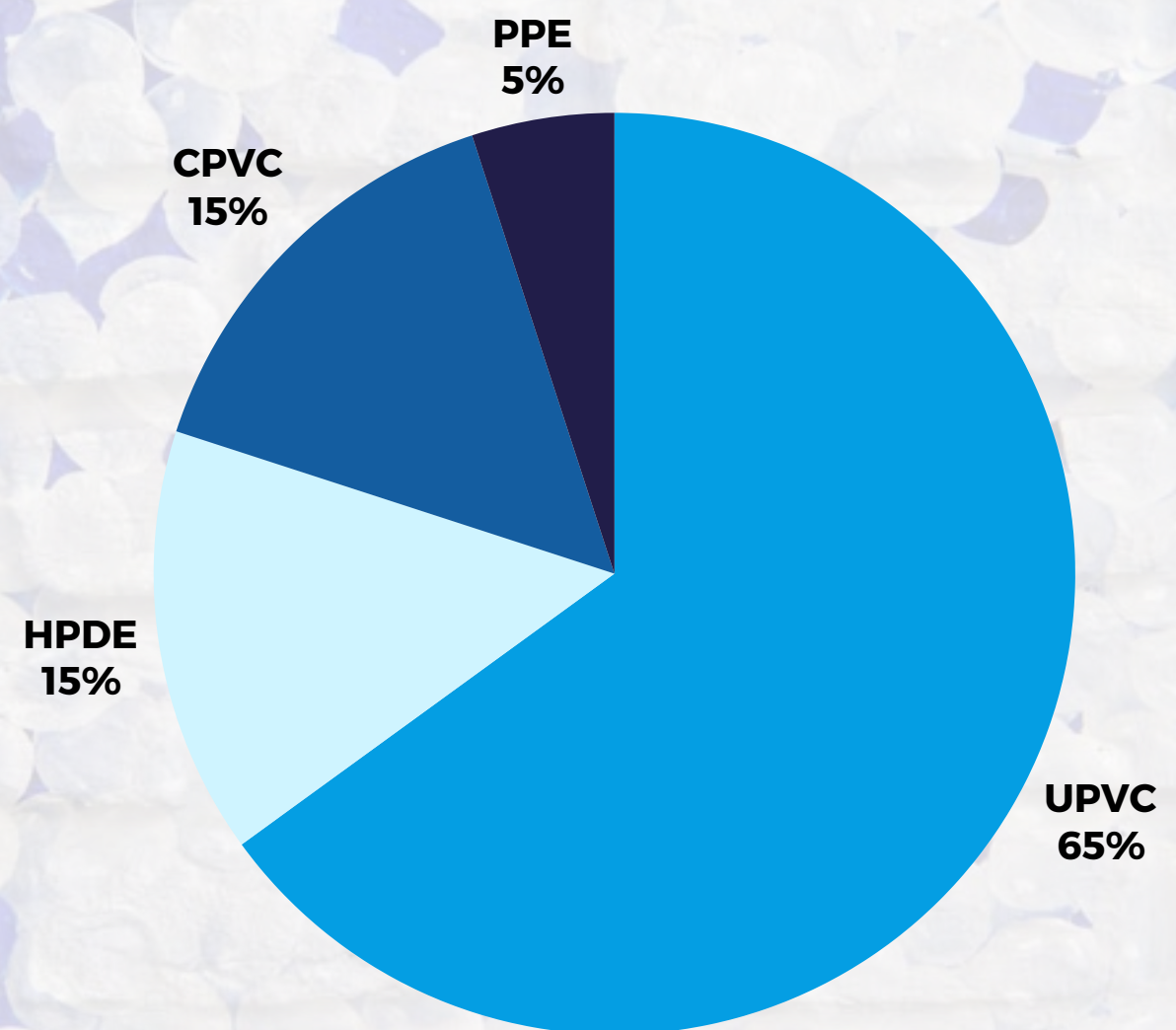

BY POLYMER

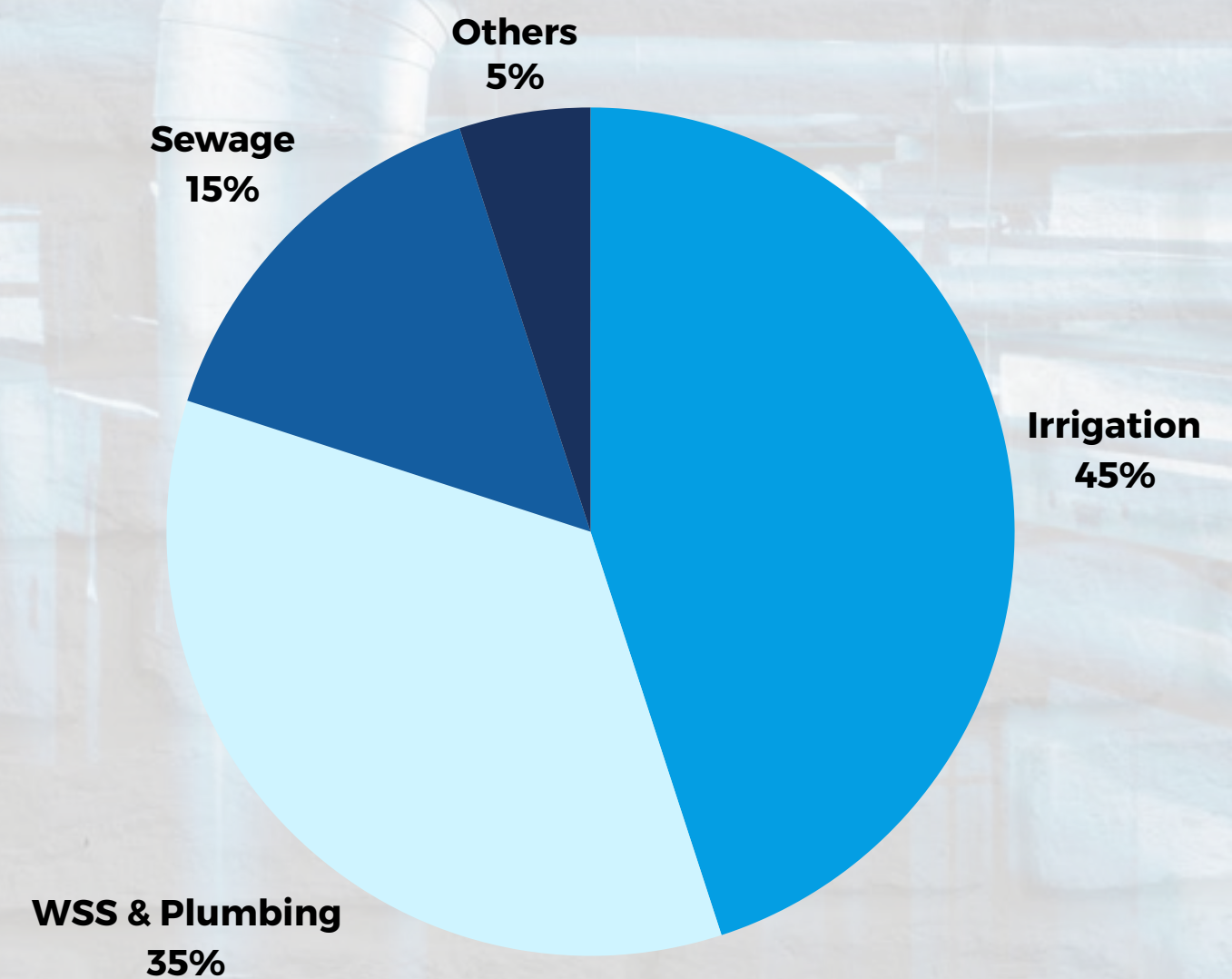

BY APPLICATION

BUSINESS SEGMENTS

AGRICULTURE SOLUTIONS



PRESSURE PIPES



COLUMN PIPES

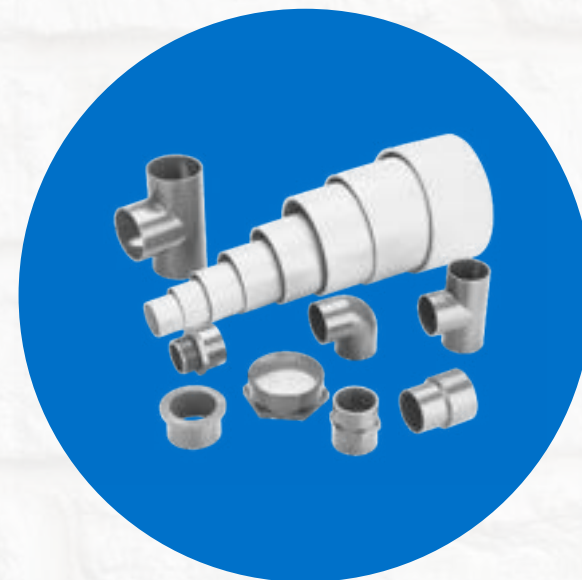

AGRI FITTINGS

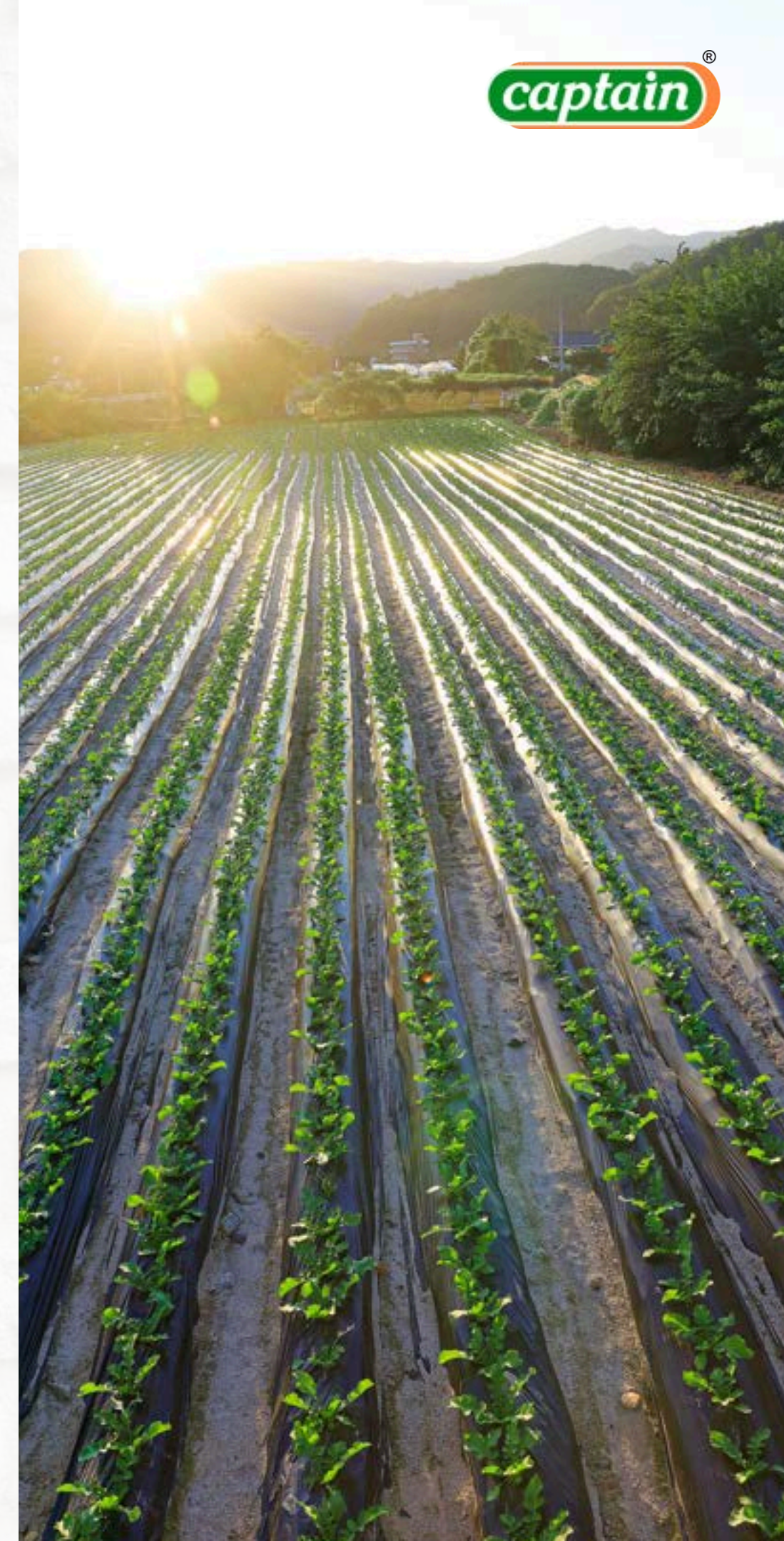

BUSINESS SEGMENTS

PLUMBING SOLUTIONS



UPVC PIPES & FITTINGS



CPVC PIPES & FITTINGS

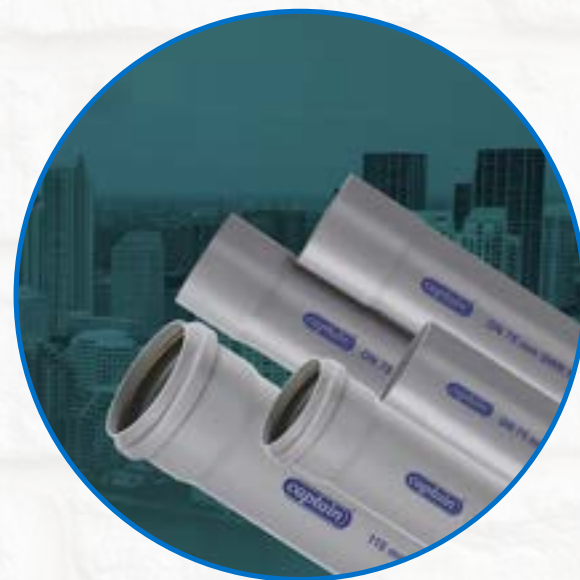

SWR PIPES & FITTINGS



PRODUCT PORTFOLIO

captain[®]

AN ISO 9001 : 2015 CERTIFIED COMPANY



UPVC COLUMN PIPES & FITTINGS



RIGID UPVC PIPES & FITTINGS

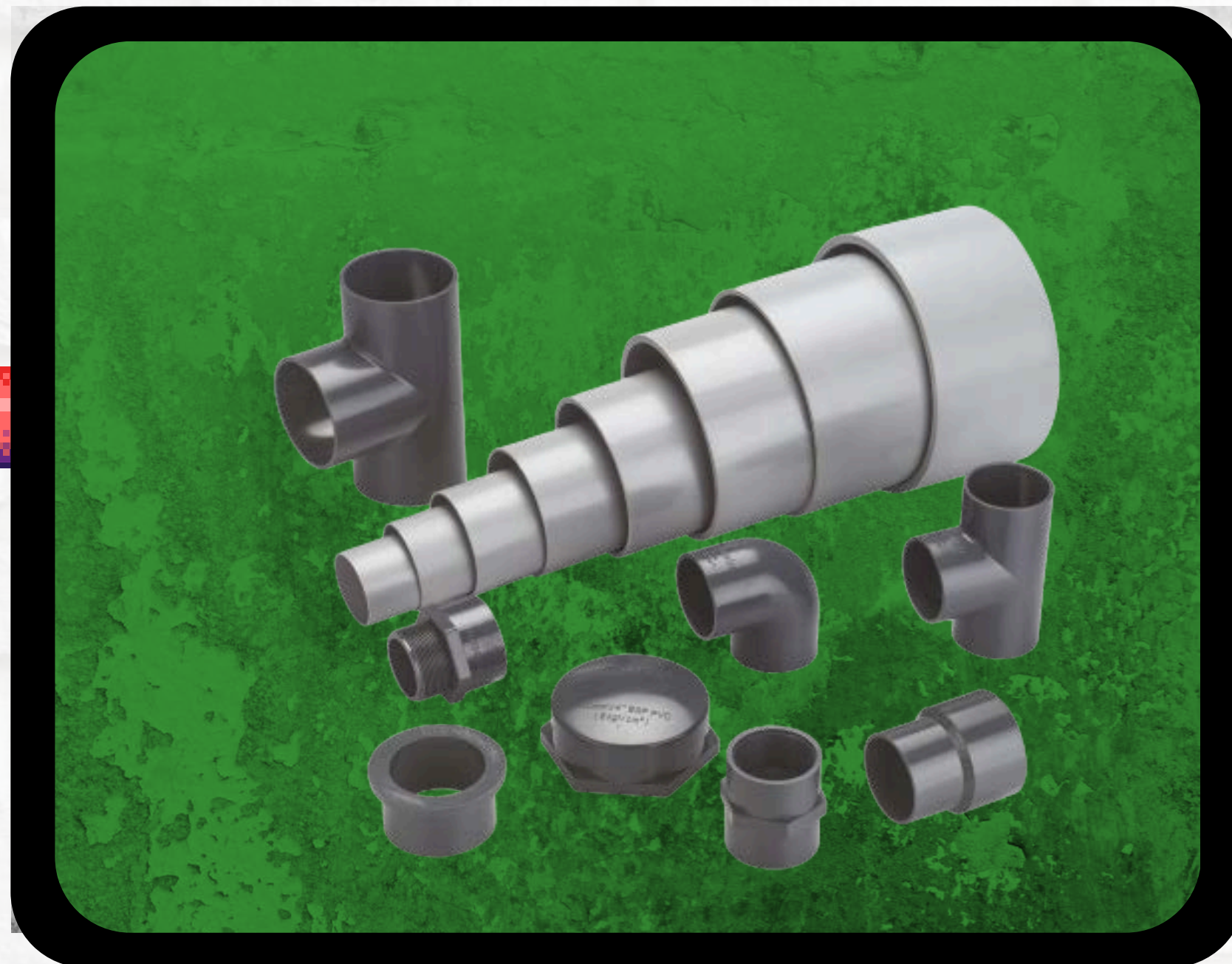

-  High Corrosion Resistance
-  Strength & Quality
-  Chemical Resistance
-  Cost Effective
-  Easy To Install

CPVC PLUMBING SYSTEMS

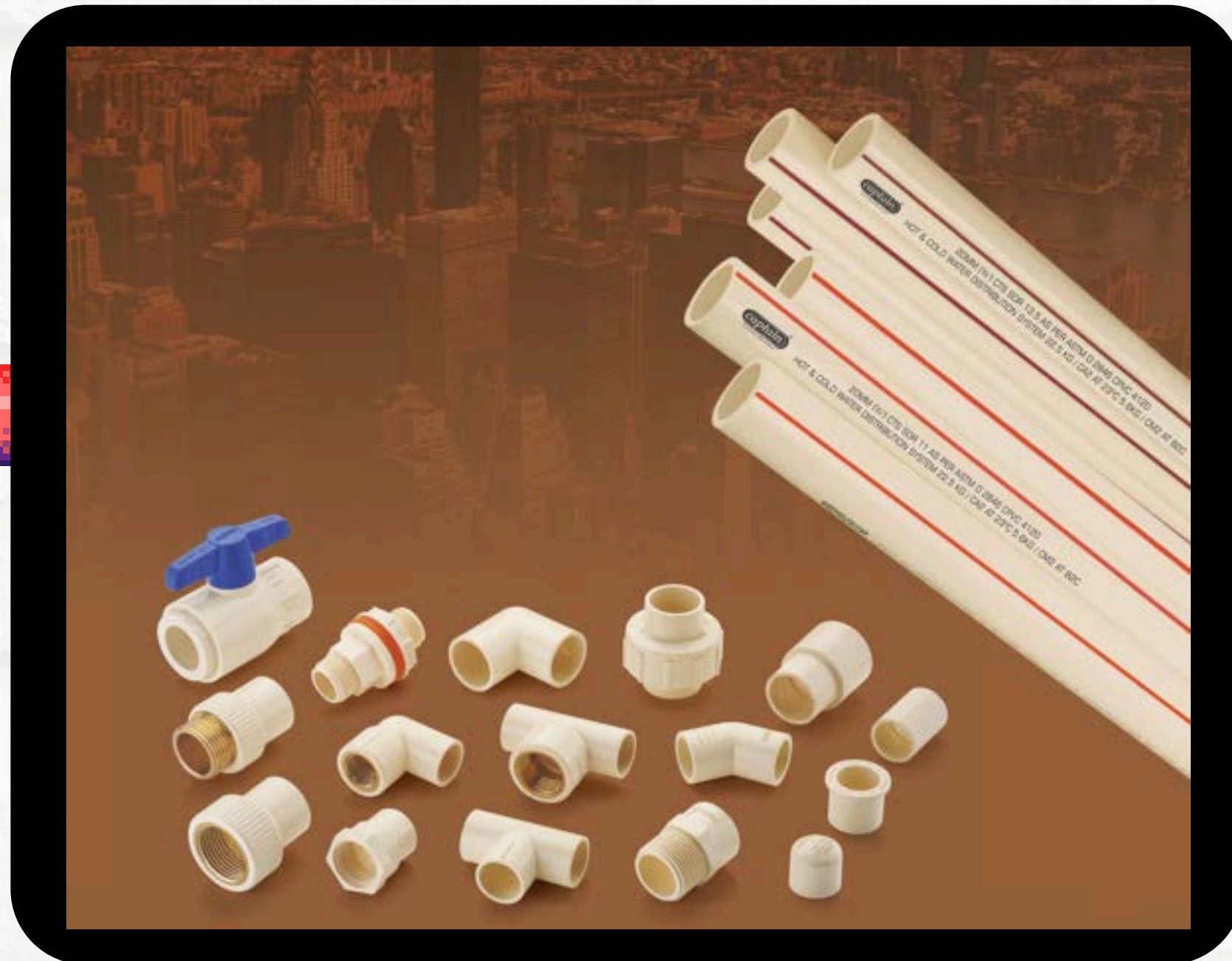

-  **Pb**
Lead Free
-  **93°C**
Suitable up to
-  **Fire Resistant**
-  **UV resistant**
UV Resistant
-  **Chemical Resistance**

SWR PIPES & FITTINGS



- 
Leak proof Joints
- 
Strong and Durable
- 
Chemical Resistance
- 
Cost Effective
- 
Easy To Install

UPVC PLUMBING SYSTEMS



- 
Bacteria Proof
- 
UV Resistant
- 
Chemical Resistance
- 
Light Weight
- 
Easy Handling

MARKETING COMMUNICATION



MARKETING COMMUNICATIONS

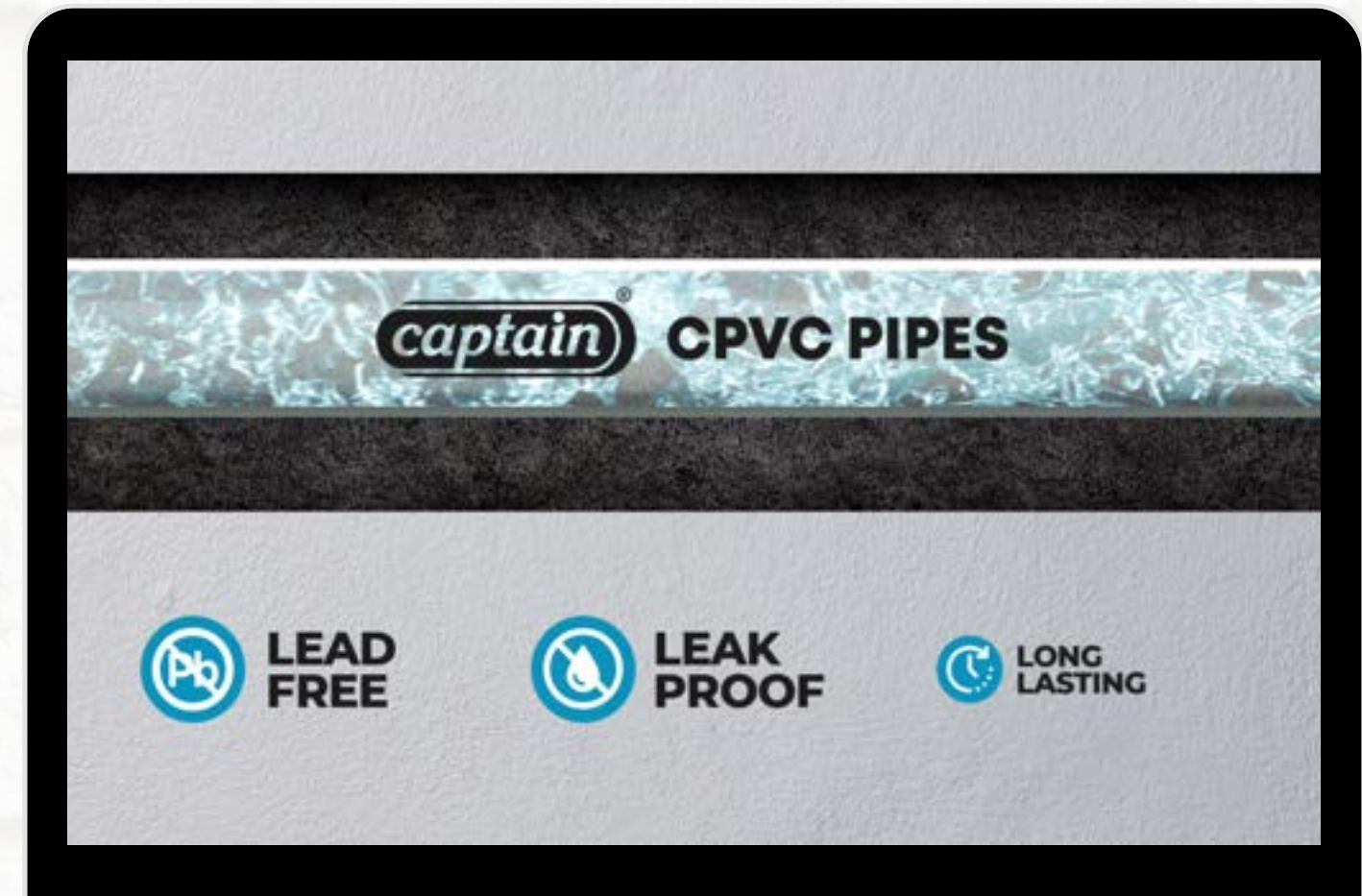

Captain Pipes Launched TV Ad campaign focusing on product features.

The TVC aimed to increase brand awareness and educate prospective consumers about various benefits of Captain CPVC pipes.

CRICKET BRANDING

Captain Pipes Launched Branding Campaign during the India vs New Zealand Cricket Match in Ahmedabad.

The branding campaign in India's most popular sport helped the brand to grab millions of eyeballs with the brand name getting featured over 60 times on TV resulting in a massive increase in brand awareness.



OUTDOOR BRANDING

The branding campaign in physical channels, especially at dealers (points of purchase) help the brand get the right exposure to influence purchase decisions

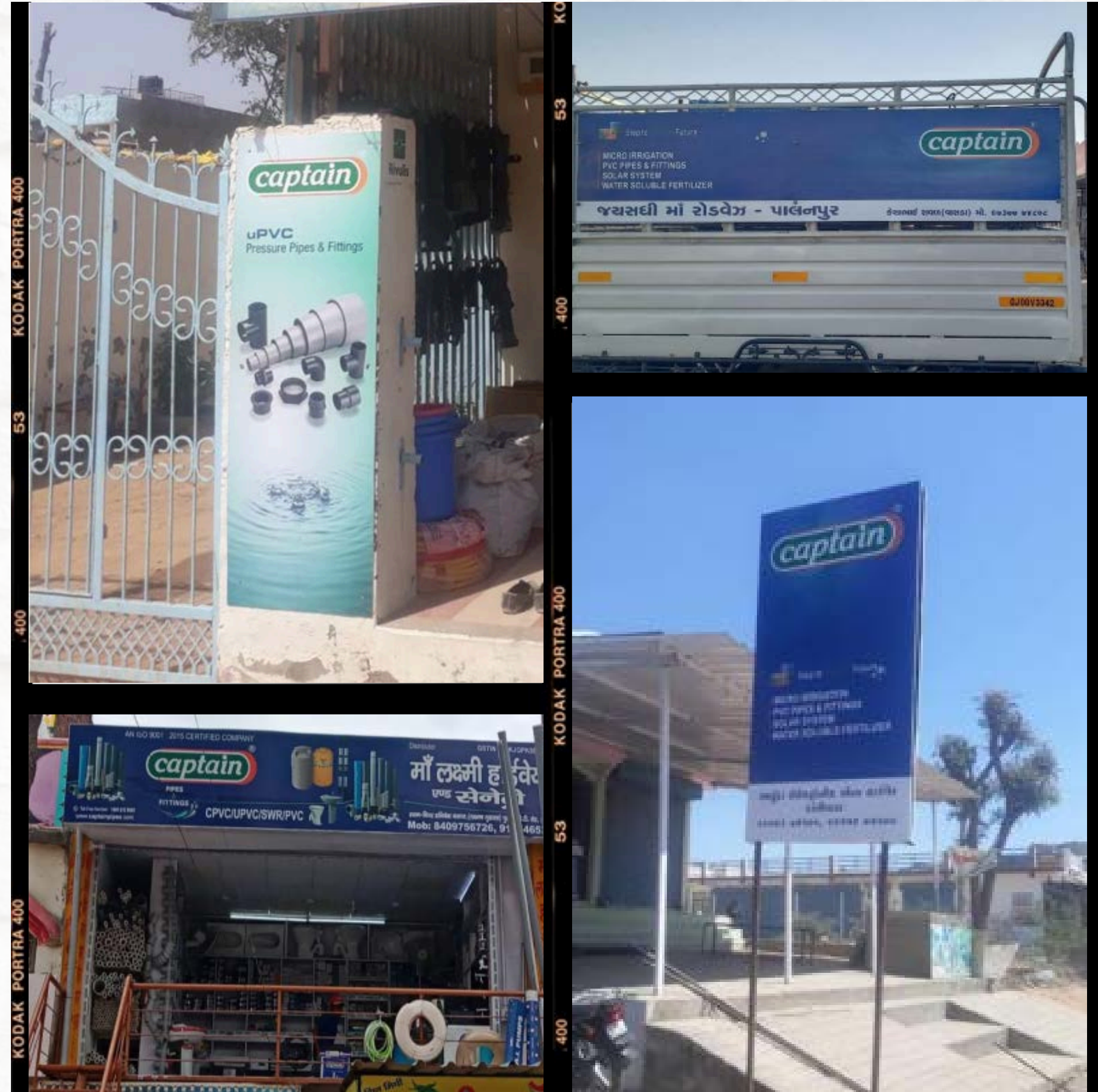

COMPANY FINANCIALS

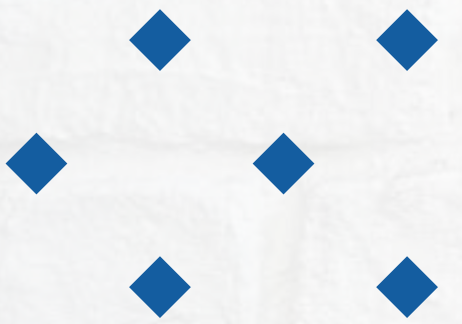

INCOME STATEMENT SUMMARY

Income Statement (INR Lakhs) Except EPS	Q4FY24	Q4FY23	YoY%	FY24	FY23	YoY%
Revenue from Operations	2026.13	2122.76	-4.55%	7634.77	8550.49	-10.71%
Revenue	2026.13	2122.76	-4.55%	7634.77	8550.49	-10.71%
Total Expenses excluding Depreciation, Amortization & Finance Cost	1819.86	1949.66		6866.39	8152.84	
EBITDA	206.27	173.1	19.16%	768.38	397.65	93.23%
EBITDA Margin (%)	10.18%	8.15%	203 bps	10.06%	4.65%	541 Bps
Depreciation & Amortization	26.7	24.87		104.79	97.94	
Finance Cost	41.14	23.52		125.22	86.97	
Other Income	4.5	6.06		11.78	33.95	
PBT before Exceptional Item	142.93	130.77		550.15	246.69	
Exceptional Items	0	0		0	0	
PBT	142.93	130.77	9.30%	550.15	246.69	123.01%
Tax	52.4	36.23		151.93	67.17	
PAT	90.53	94.54	-4.24%	398.22	179.52	121.82%
PAT Margin %	4.47%	4.45%	2 bps	5.22%	2.10%	312 Bps
Other comprehensive profit / loss	-1.13	-0.03		-3.27	1.89	
Net PAT	89.40	94.51		394.94	181.41	117.71%
Diluted EPS (In Rs)	0.06	0.07		0.27	0.13	

BALANCE SHEET



Liabilities (INR Lakhs)	As on 31.03.24	As on 31.03.23	Assets (INR Lakhs)	As on 31.03.24	As on 31.03.23
Equity & Liabilities			Assets		
1. Equity			1. Non-Current Assets:		
Equity Share Capital	1477.07	1394.57	(a) Property, Plant & Equipments	1114.56	825.65
Other Equity	1073.60	622.96	(b) Capital Work in Progress	22.50	-
			(c) Investments accounted for using Equity Method	-	-
Total Equity	2550.67	2017.53	(d) Right use of Assets	-	-
			Financial Assets		
2. Liabilities			(a) Investments	636.80	43.05
Non-Current Liabilities			(b) Loans	-	-
(a) Borrowings	258.78	187.27	(c) Other Financial Assets	95.46	144.76
(b) Lease Liabilities	-	-	Deferred Tax Assets	-	-
(c) Other Financial Liabilities	-	-	Other Non-Current Assets		
Provisions	15.10	14.22	(a) Long-Term Loans and Advances	-	-
Deferred Tax Liabilities Net	47.04	50.81	(b) Other Non-Current Assets	-	-
Other Non-Current Liabilities					
Total Non-Current Liabilities	320.92	252.30	Total Non-Current Assets	1869.32	1013.46
Financial Liabilities			2. Current Assets		
Borrowings	322.76	69.21	Inventories	1184.74	977.64
(a) Lease Liabilities	-	-	Financial Assets		
(b) Trade Payables			(a) Trade Receivables	1185.19	951.42
total outstanding dues of micro enterprises and small enterprises	100.82	183.5	(b) Cash and Cash Equivalents	1.14	260.75
total outstanding dues of others	780.27	691.79	(c) Bank Balance other than Cash and Cash Equivalents	-	-
Other Financial Liabilities	-	-	Other Financial Assets	20.40	19.09
Other Current Liabilities	134.86	54.01	Other Current Assets	61.00	88.71
Provisions	11.49	10.98			
Current Tax Liabilities (Net)	100	31.75	-	-	-
Total Current Liabilities	1450.20	1041.24	Total Current Assets	2452.47	2297.61
Total Liabilities	1771.12	1293.54	Total Assets	4321.79	3311.09
Total Equity and Liabilities	4321.79	3311.07			

FINANCIAL SUMMARY (Q4FY24)

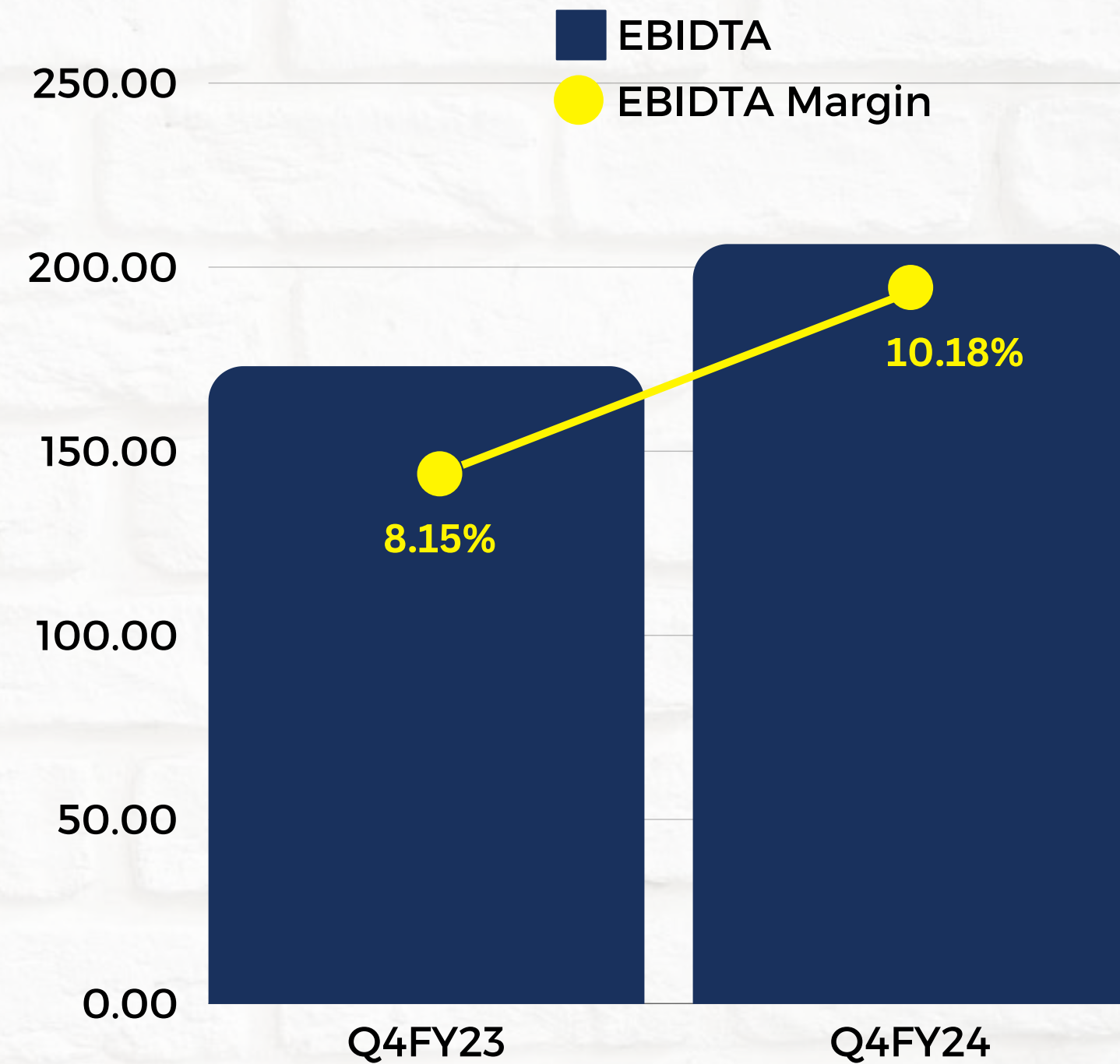
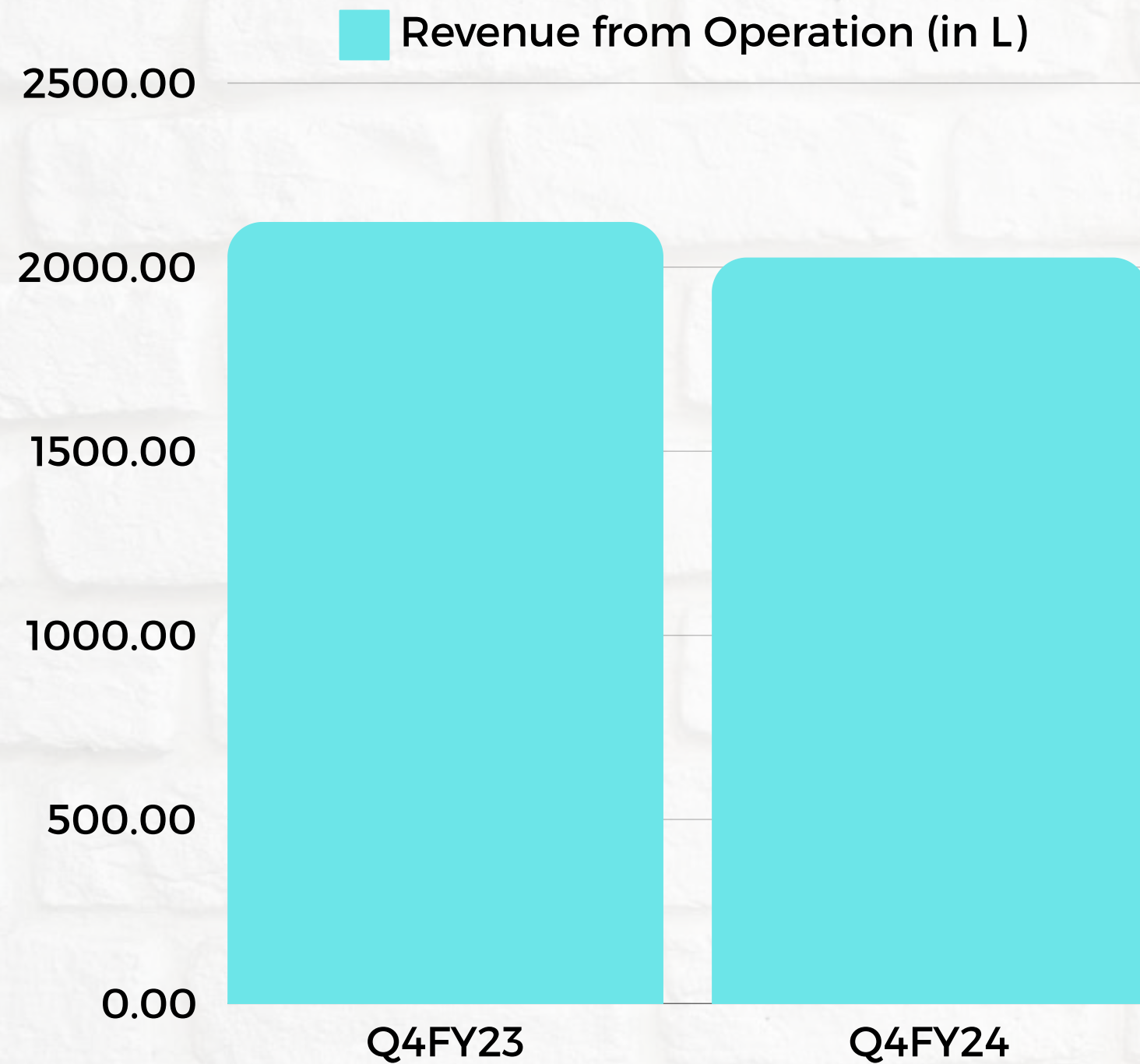

FINANCIAL SUMMARY (Q4FY24)

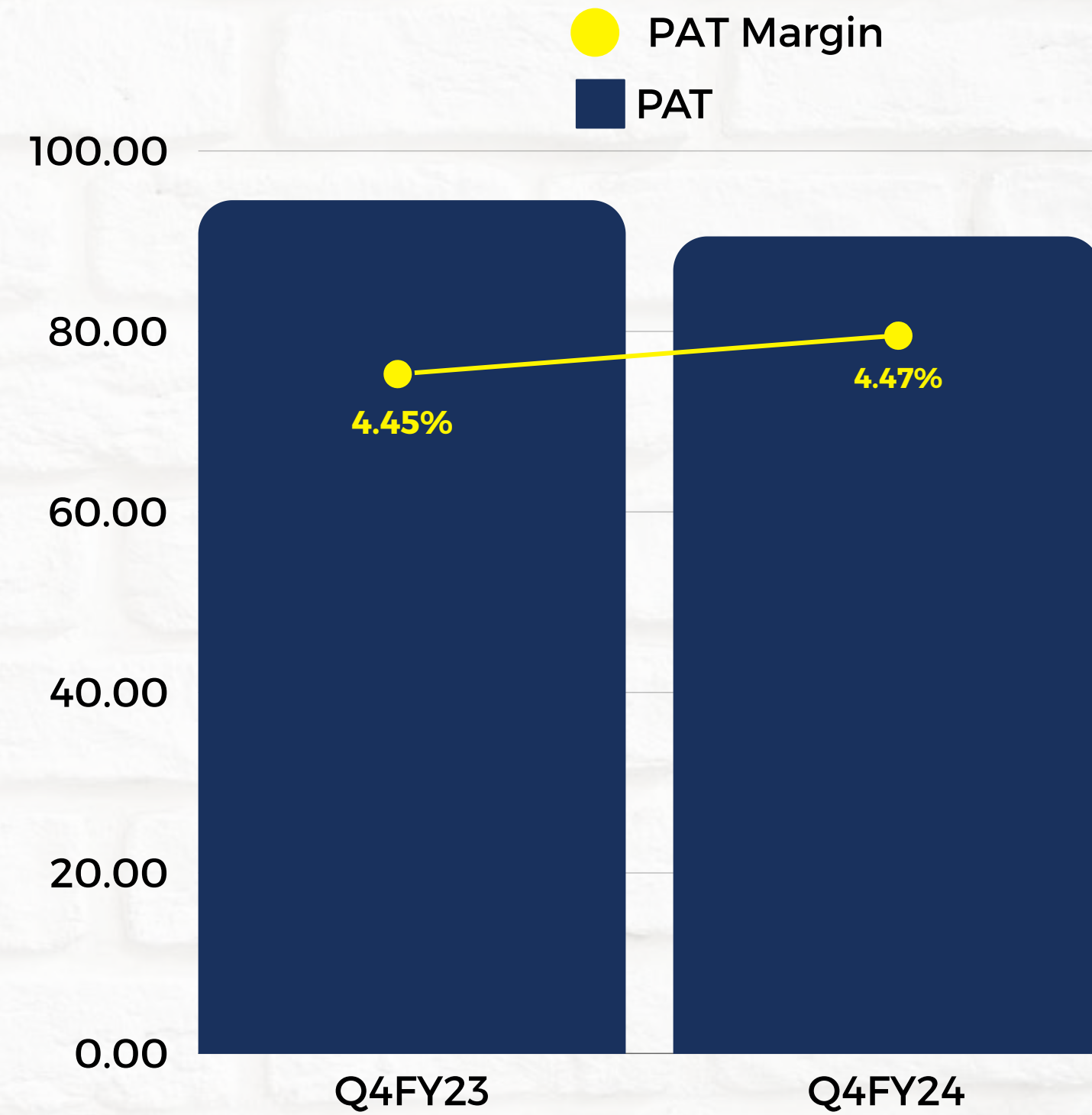
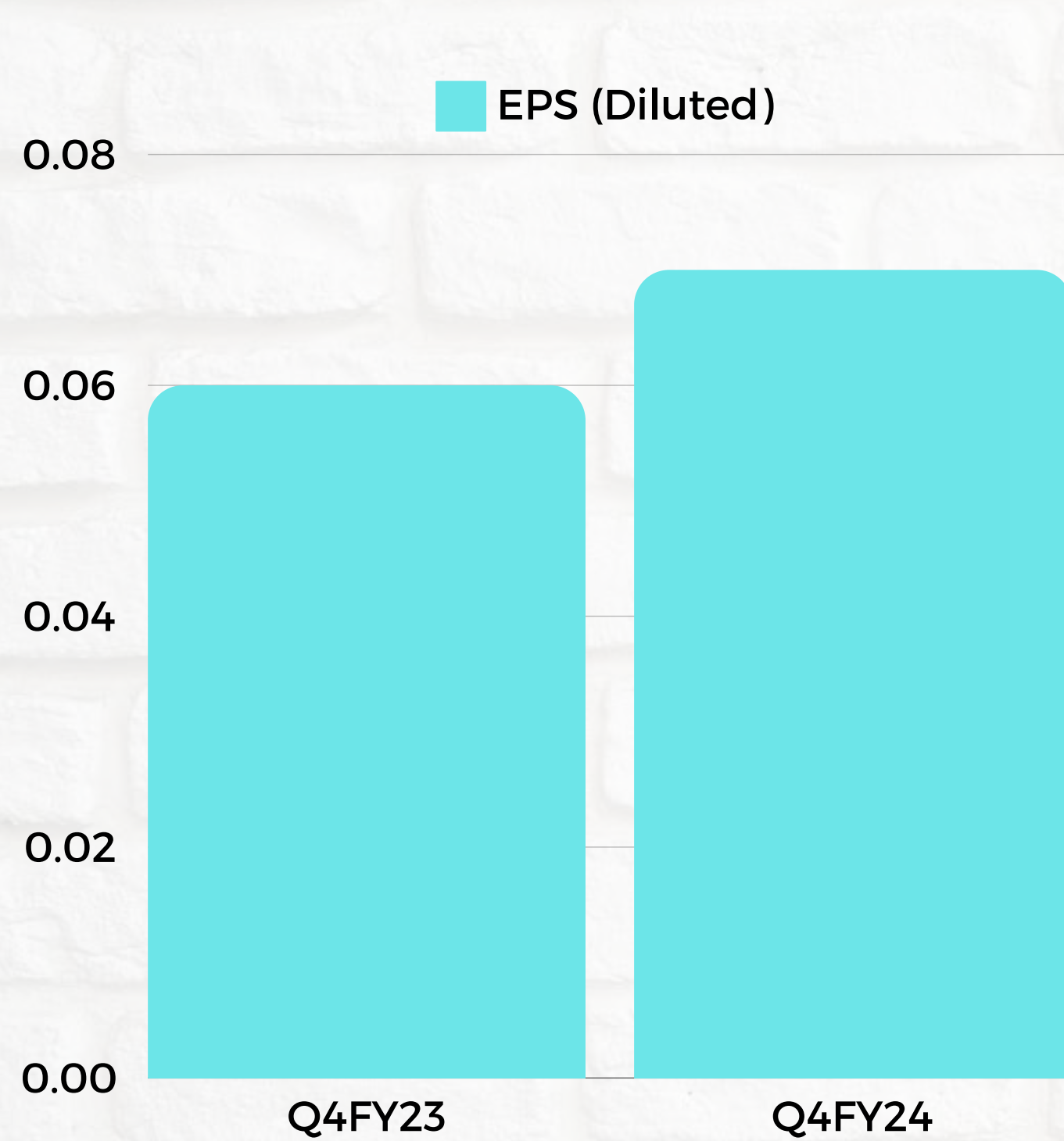

FINANCIAL SUMMARY (FY24)

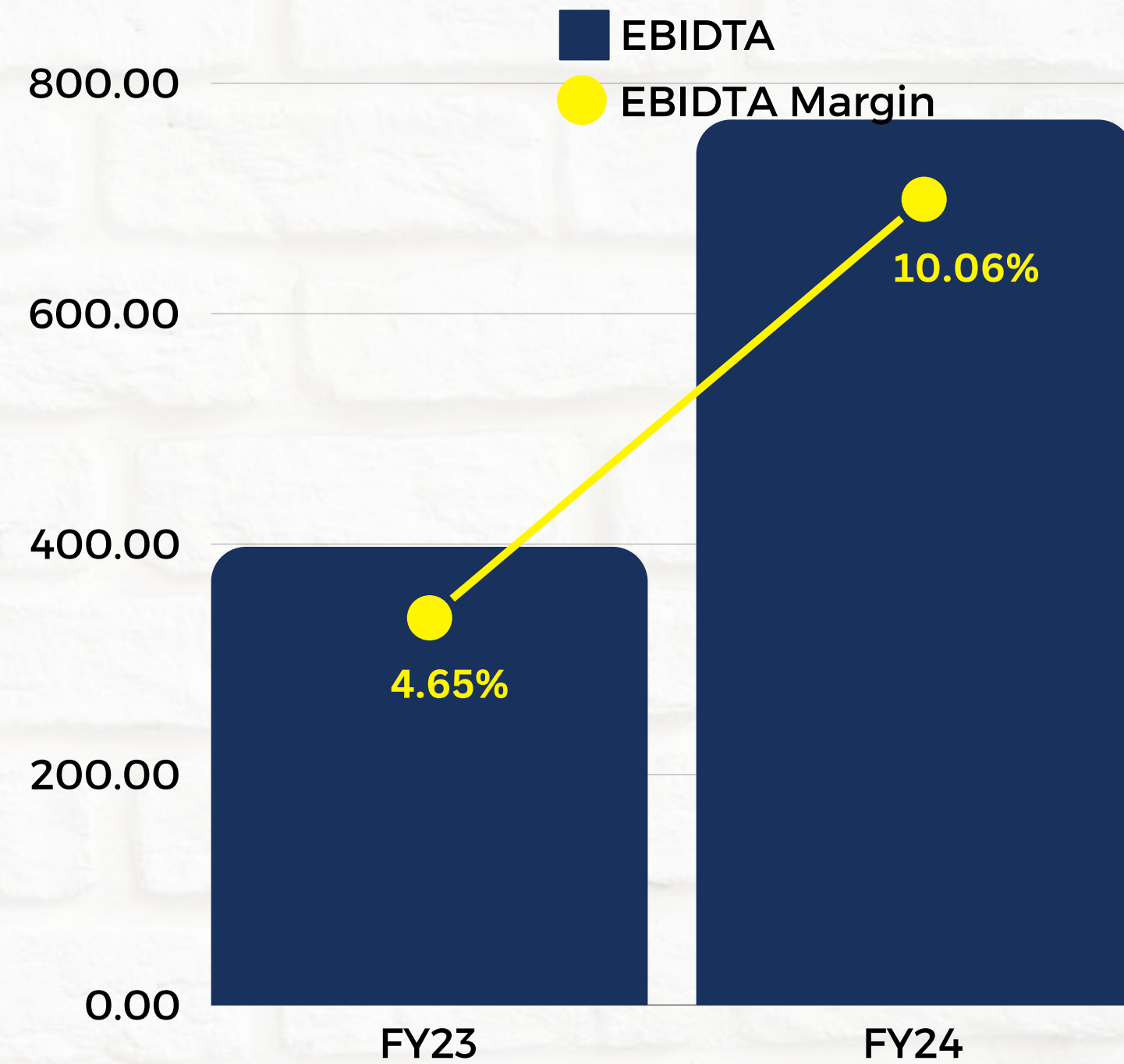
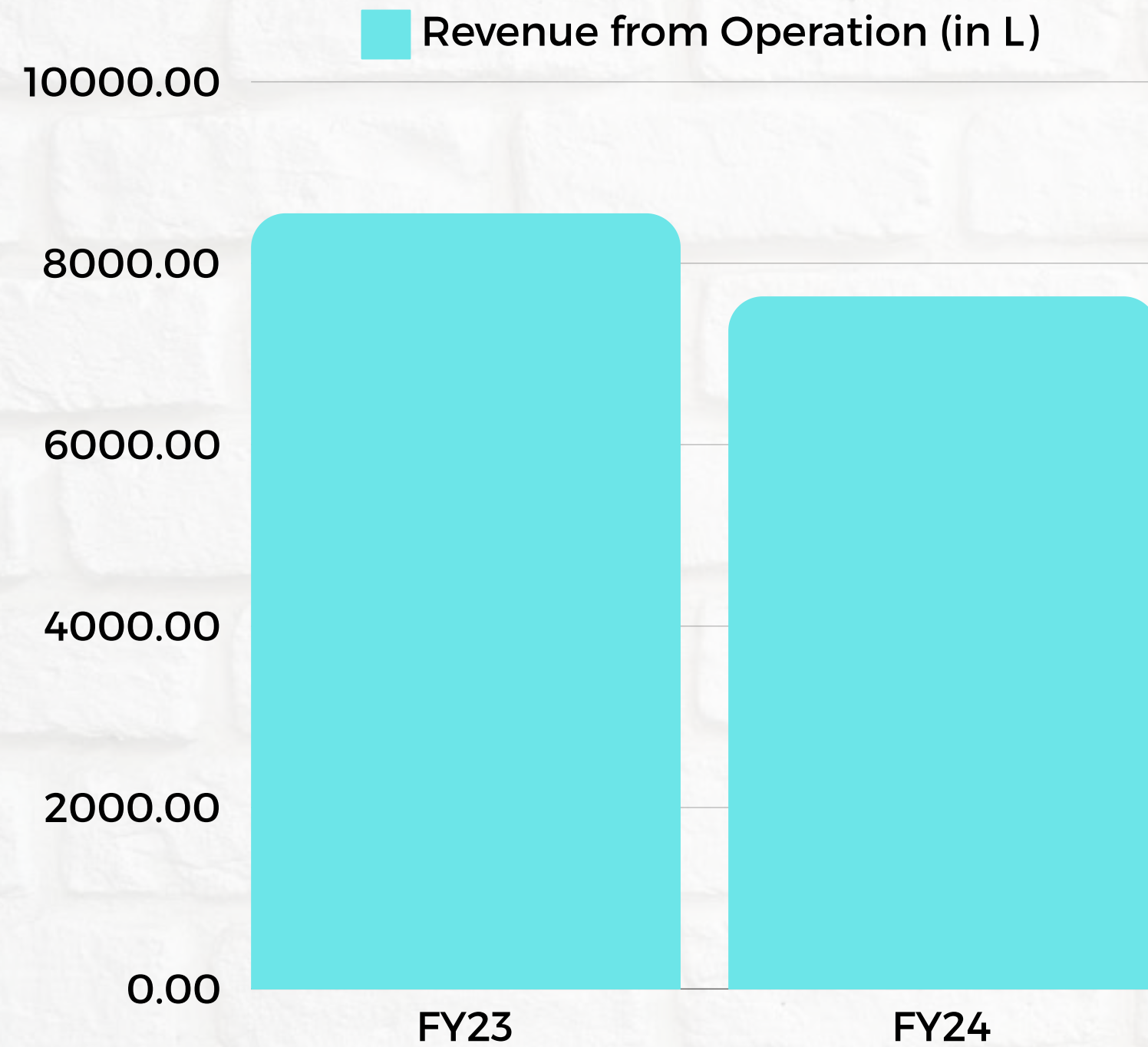

FINANCIAL SUMMARY (FY24)

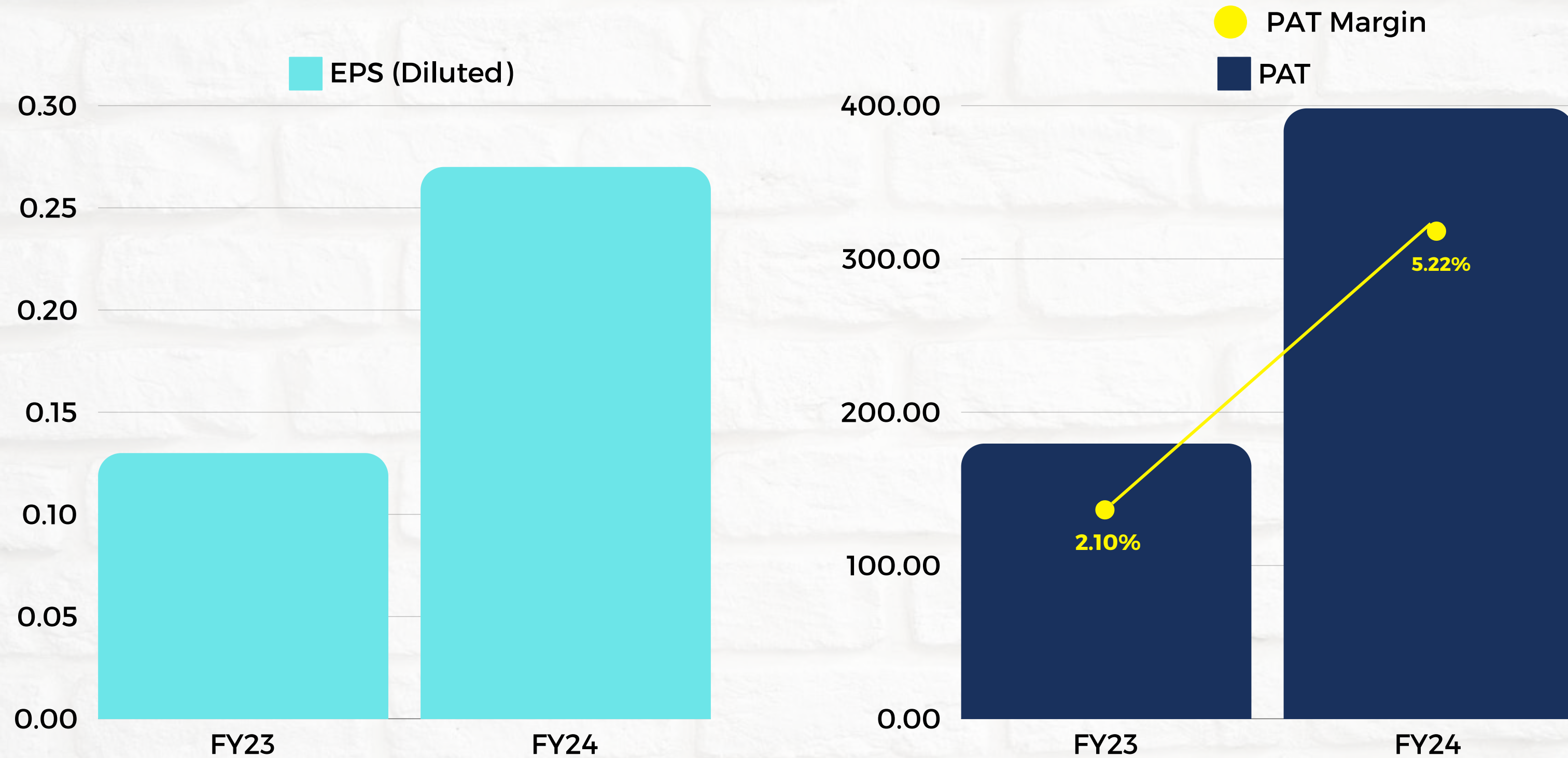

MANAGEMENT COMMENTS



After releasing our FY24 earnings, we recognize the nuanced dynamics reflected in our performance metrics. Although Revenue from Operations declined by 10.7% from Rs. 8550 lakhs in FY23 to Rs. 7635 lakhs in FY24, we have made encouraging progress in other areas. Our EBITDA surged impressively by 93%, soaring from Rs. 398 Lakhs in FY23 to Rs. 768 Lakhs in FY24.

This notable ascent in EBITDA is complemented by a remarkable enhancement in EBITDA margins, escalating from 4.65% in FY23 to 10.06% in FY24, marking an uptick of 541 basis points. As a result, we are committed to enhancing margins and cutting costs, and we have shifted our product mix to be more profitable, featuring higher-margin products.

Further, our Profit After Tax (PAT) experienced a significant spike, leaping by 121% from Rs. 179 Lakhs in FY23 to Rs. 398 Lakhs in FY24, underscoring our sustained commitment to operational excellence and fiscal prudence. In addition to our financial performance, we are pleased to inform you that construction on our new plant near Ahmedabad is underway, as previously communicated.

As our efforts progress as planned, we anticipate launching commercial production in FY25, a milestone that demonstrates our commitment to growing our business footprint and strengthening our market position. As we navigate the evolving landscape of our industry, we remain resolutely focused on leveraging our strengths, optimizing efficiencies, and capitalizing on growth opportunities to drive sustained value for our stakeholders.

MANAGEMENT GUIDANCE

1

Volume Target
CAGR (3 Years) - **20%**

2

Product Mix Expansion to raise
margins to **Double Digits**

3

PVC Price Stabilization to drive
**Predictable & Consistent
Growth**



CAPITAL MARKET DATA



FROM 10 MAY 2023 TO 10 MAY 2024

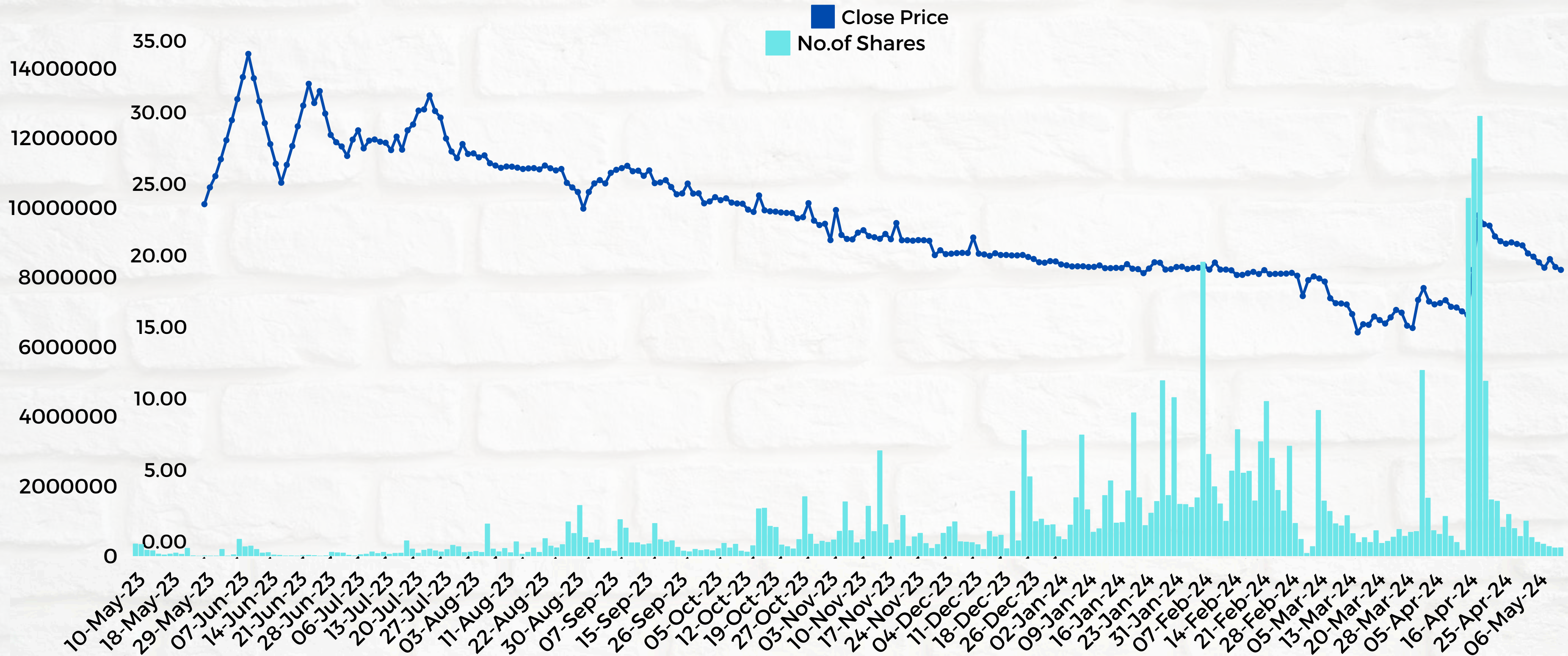

Data as per BSE, stock price adjusted for stock split & bonus

CAPITAL MARKET DATA

Price Data (As on close 15th May 2024)	
Face Value (INR)	1.0
52 Week H/L (INR)	35.79/14.10
Market Cap (INR Cr)	292.61
Average Daily Trading Volume (Last Year)	951375

Data as per BSE, stock price adjusted for stock split & bonus

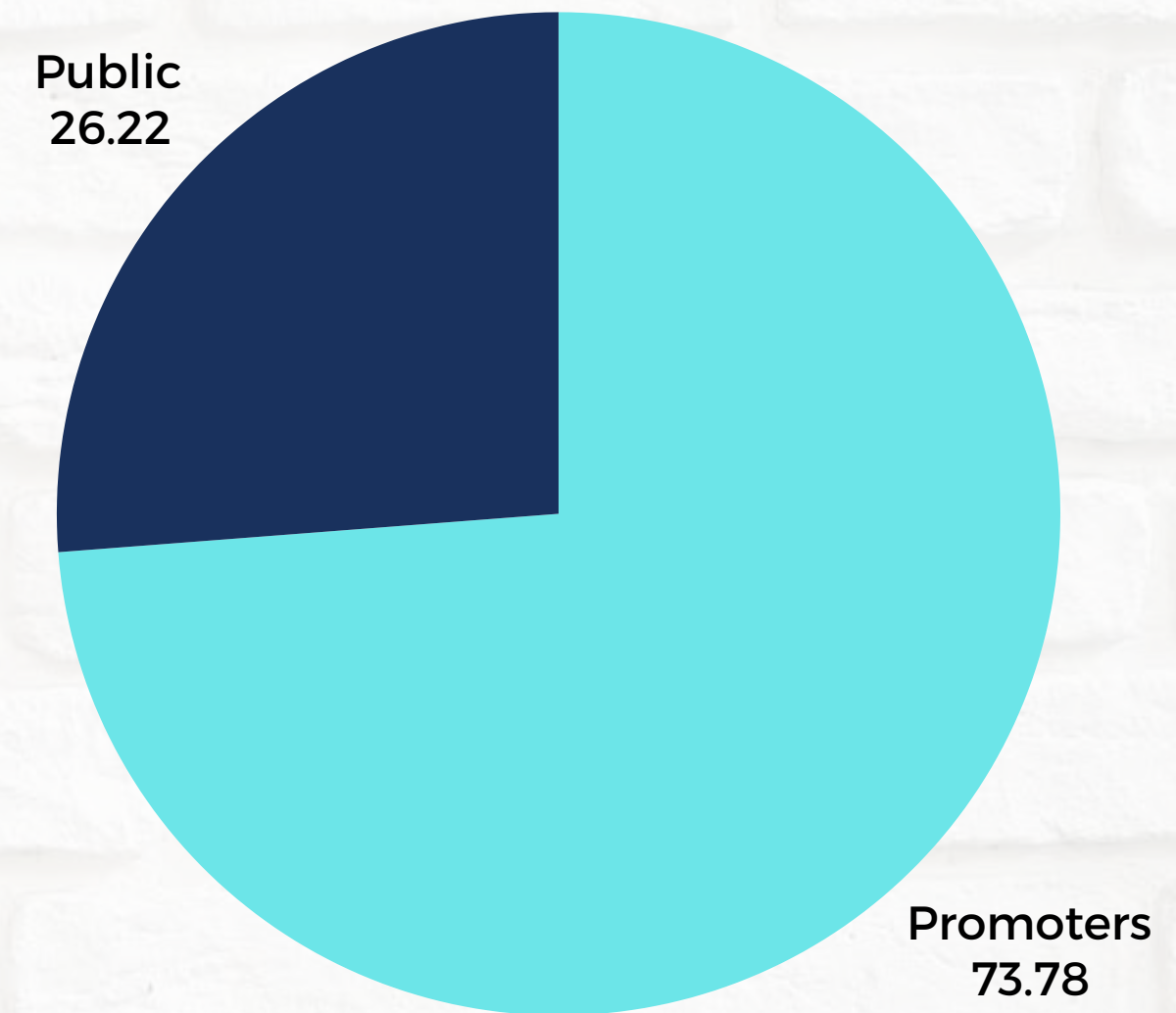

Shareholding Pattern (As of 31 Mar 2024)

CAUTION: FORWARD LOOKING STATEMENTS

The information in this presentation has been prepared for use in presentations by Captain Pipes Limited (the “Company”) for information purposes only and does not constitute, or should be regarded as, or form part of any offer, invitation, inducement or advertisement to sell or issue, or any solicitation or initiation of any offer to purchase or subscribe for, any securities of the Company in any jurisdiction, nor shall it, or the fact of its distribution form the basis of, or be relied on in connection with, any investment decision or any contract or commitment to purchase or subscribe for any securities of the Company in any jurisdiction.

No representation or warranty, express or implied, is made as to, and no reliance should be placed on, the fairness, accuracy, completeness or correctness of the information or opinions contained in this presentation. Neither the Company nor any of its affiliates, advisors or representatives shall have any responsibility or liability whatsoever (for negligence or otherwise) for any loss howsoever arising from any use of this presentation or its contents or otherwise arising in connection with this presentation. The information set out herein may be subject to updating, completion, revision, verification and amendment and such information may change materially. This presentation is based on the economic, regulatory, market and other conditions as in effect on the date hereof. It should be understood that subsequent developments may affect the information contained in this presentation, which neither the Company nor its affiliates, advisors or representatives are under an obligation to update, revise or affirm.

This presentation contains forward-looking statements based on the currently held beliefs and assumptions of the management of the Company, which are expressed in good faith and, in their opinion, reasonable. Forward-looking statements involve known and unknown risks, uncertainties and other factors, which may cause the actual results, financial condition, performance, or achievements of the Company or industry results, to differ materially from the results, financial condition, performance or achievements expressed or implied by such forward-looking statements. Unless otherwise indicated, the information contained herein is preliminary and indicative and is based on management information, current plans and estimates. Industry and market-related information is obtained or derived from industry publications and other sources and has not been independently verified by us. Given these risks, uncertainties and other factors, recipients of this document are cautioned not to place undue reliance on these forward-looking statements. The Company disclaims any obligation to update these forward-looking statements to reflect future events or developments.

Impress Strategic Communications Pvt Ltd. (Impress IR) is an Independent Investor Relations Management Service company. This Presentation has been prepared by Impress IR based on information and data which the Company considers reliable, but Impress IR and the Company makes no representation or warranty, express or implied, whatsoever, and no reliance shall be placed on, the truth, accuracy, completeness, fairness and reasonableness of the contents of this Presentation. This Presentation may not be all inclusive and may not contain all of the information that you may consider material. Any liability in respect of the contents of, or any omission from, this Presentation is expressly excluded. Impress IR also hereby certifies that the directors or employees of Impress IR do not own any stock in personal or company capacity of the Company under review.

THANK YOU



Investor Relations Advisor:

Brijesh K

Impress Strategic Communications Pvt Ltd

info@impressir.com