



Jamna Auto Industries Ltd.

January 31, 2019

To,
BSE Limited
Phiroze Jeejeebhoy Towers, Dalal Street,
Mumbai- 400001 Maharashtra

BSE Code: 520051

To,
National Stock Exchange of India Limited
Exchange Plaza, Plot no. C/1, G Block,
Bandra-Kurla Complex, Bandra (E)
Mumbai - 400 051, Maharashtra
NSE Code: JAMNAAUTO

Subject–Presentation on the financial results of third quarter of Financial Year 2018-19

Dear Sir,

Pursuant to the requirements of Regulation 30 and Regulation 46 of SEBI (Listing Obligations & Disclosure Requirements) Regulations, 2015, we are enclosing herewith the presentation by the Company pertaining to the financial results of third quarter of Financial Year 2018-19.

Kindly take the above information on record.

Thanking you,

Yours faithfully,

For Jamna Auto Industries Limited

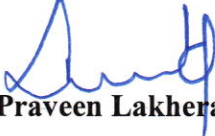
Praveen Lakhera

Company Secretary & Head-Legal



Encl: As above

Investors' Presentation Q3 FY'19



Future Ready for Growth...

Company Overview



JAI TODAY

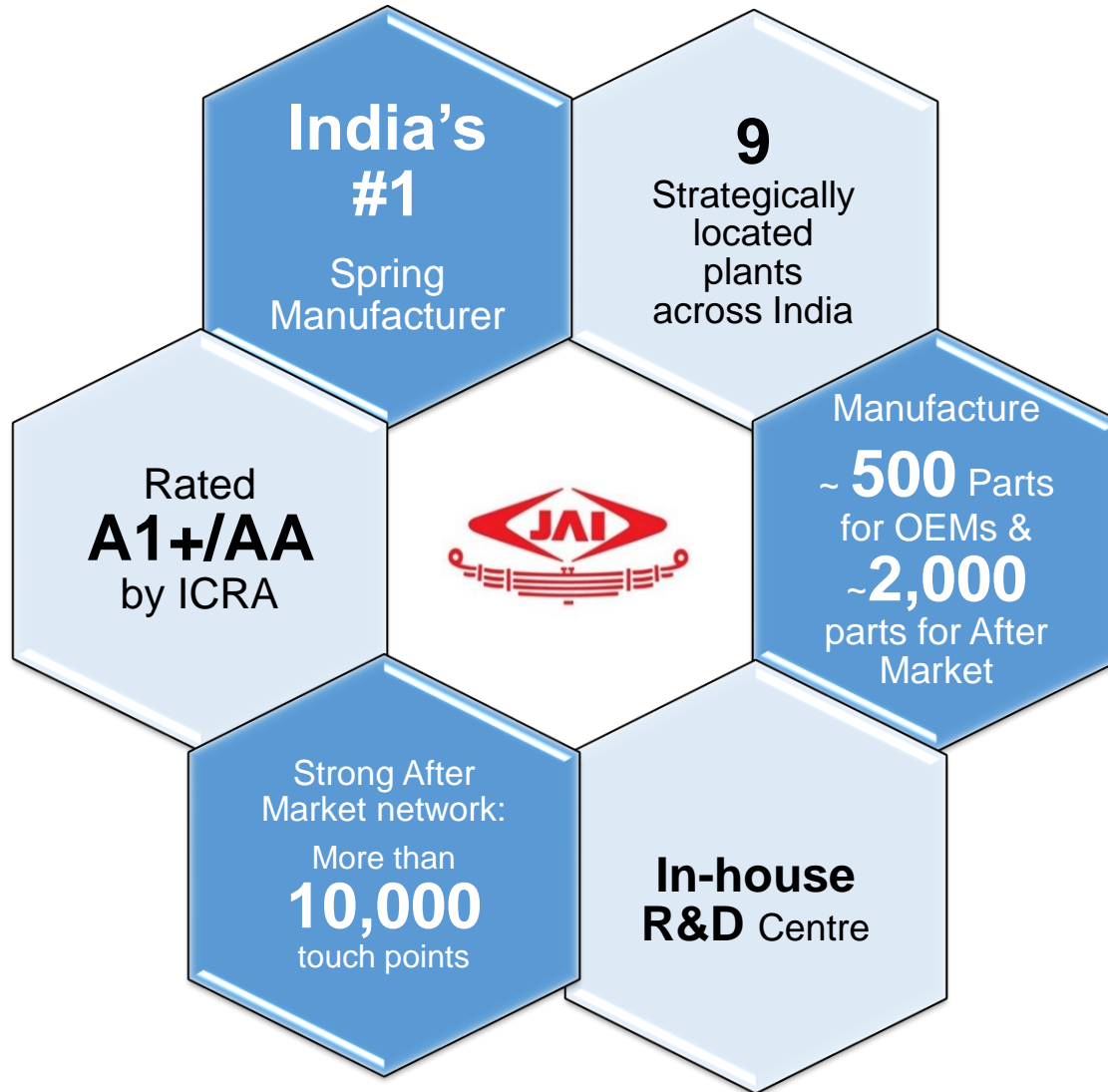

Jamna Auto Industries Limited is referred to as "JAI" hereafter

JAI's Transformational Journey

	FY 2014	FY 2018
Locations	5	9
Capacity	180,000 MTPA*	240,000 MTPA*
Products	Conventional Leaf Spring Parabolic Spring Lift Axle	Conventional Leaf Spring Parabolic Spring Lift Axle Air Suspension
Revenue	₹833 crore	₹1,738 crore
Market Capitalization	₹350 crore	₹3,500 crore
ROCE	12%	51%
Dividend	33%	33%

* MTPA refers to Metric Tons per Annum

JAI's Corporate Strategy : Growth and Diversification

Expand Locations

Manufacturing Plants

- Yamuna Nagar
- Malanpur
- Chennai 1- Leaf Spring
- Chennai 2- Suspension
- Jamshedpur
- Pune
- Hosur

Assembly Plants

- Lucknow*
- Pant Nagar*

Upcoming Plants

- Indore
- Adityapur*

*Under subsidiaries of Jamna

Diversify Products

Existing Products

- Leaf Spring
- Parabolic Spring
- Lift Axle
- Air Suspension

Products in the pipeline

- Stabilizer Bar
- U Bolt
- Z Springs
- Trailer Suspension

De-risk Markets

Existing Markets

- OE India
- AM India
- AM Exports
- OE Exports

Key Strengths

Team of expert, innovative, self driven people

Best in class manufacturing facilities

Largest Supplier to Tata, Leyland & Daimler

Prudent financial management policies

JAI's Corporate Strategy : Lakshya

Operational Goals

Financial Goals

GOALS

Product De-risking

Diversifying Markets

Maximizing Returns

Value Creation

33%

Revenue from
New Products

33%

Revenue from
New Market

33%

ROCE

33%

Dividend
Payout

ACHIEVED
FY'18

37%

Revenue from
New Products

15%

Revenue from
New Market

51%

ROCE

33%

Dividend*
Payout

**9th consecutive year of dividend payout*

JAI's Product Portfolio

Existing Products

1) Conventional Leaf Spring



2) Parabolic Leaf Spring



3) Lift Axle

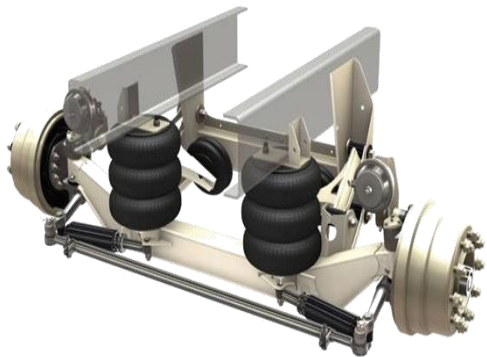

4) Air Suspension

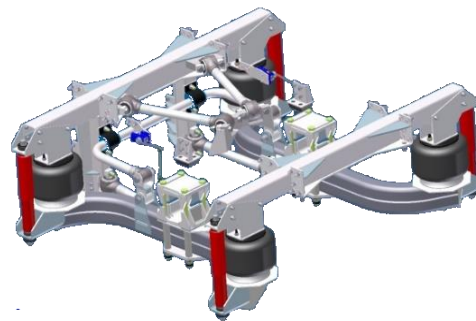

Upcoming Products

Stabilizer Bar



U Bolt



Z Spring



Trailer Suspension

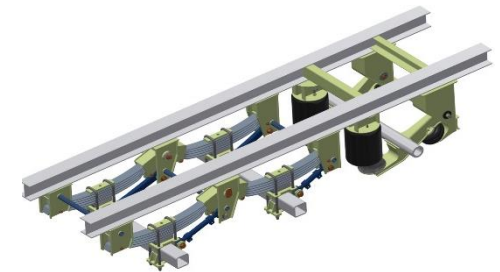

JAI's Plants: Strategically located across CV hubs

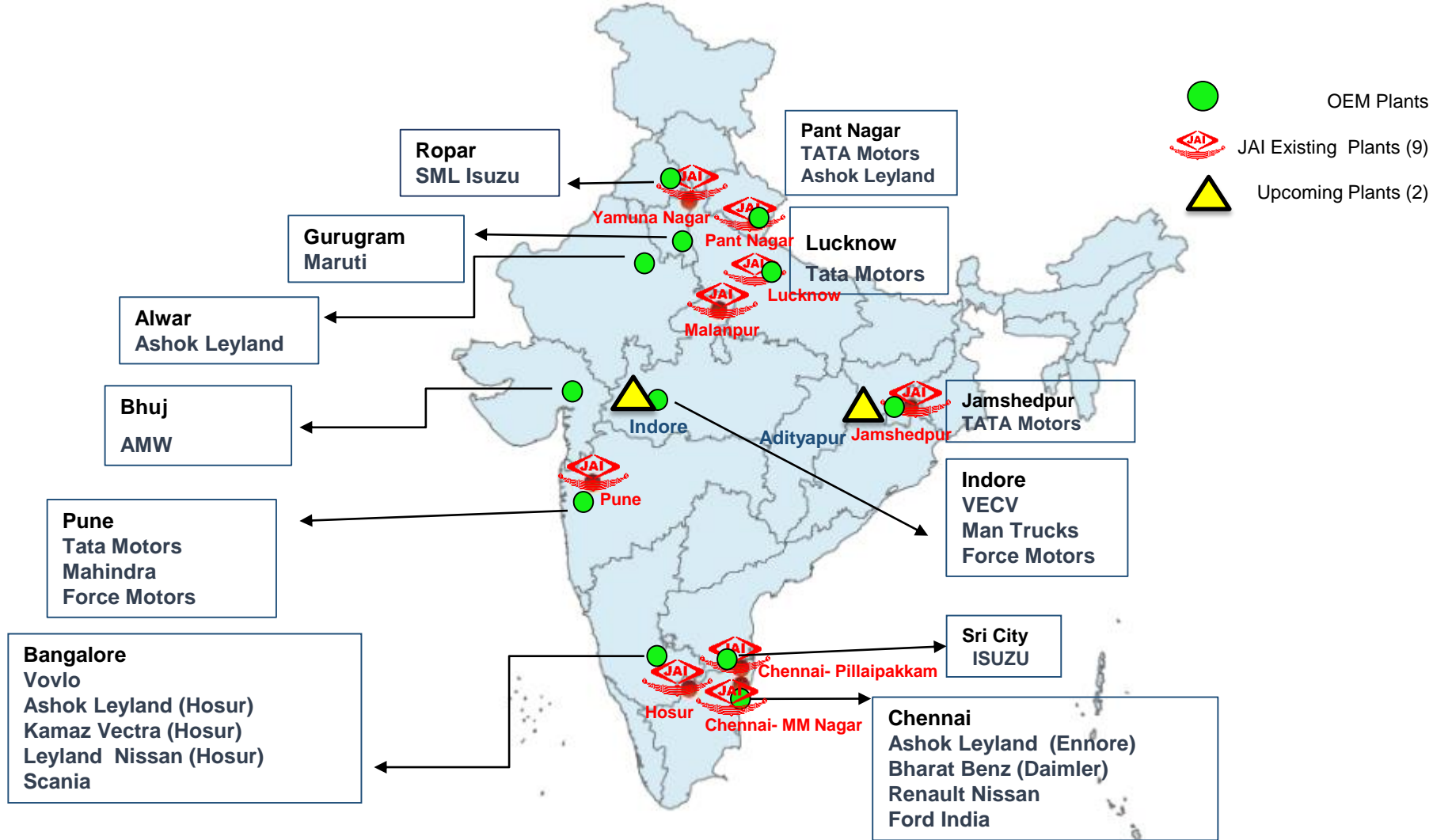

Map Source: as available on www.surveyofindia.gov.in dated 17.02.2017
The Map is for illustrative purpose only

JAI's OEM Customers



Shareholding Pattern as on Dec 31, 2018

Category-wise break-up

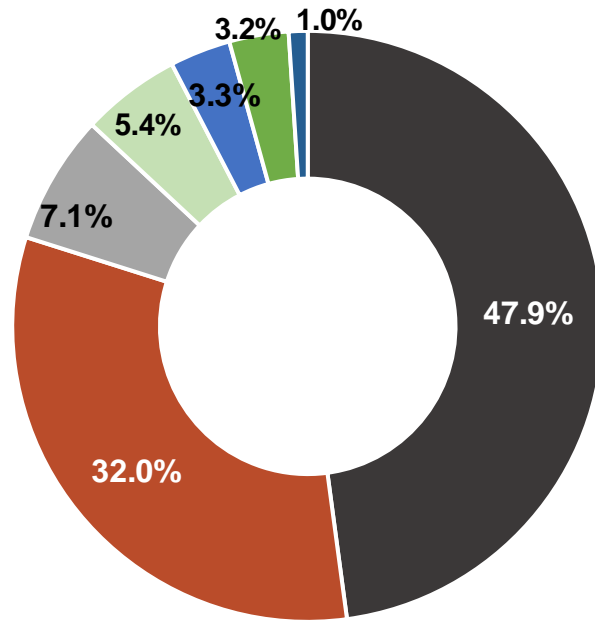

- Promoters
- Individuals
- Mutual Funds
- Foreign Portfolio Investors
- Bodies Corporate
- Financial Institutions & Others
Banks / Others

Category	No of shares	in %
Promoters	190,773,150	47.9
Individuals	127,528,821	32.0
Mutual Funds	28,201,367	7.1
Foreign Portfolio Investors	21,636,380	5.4
Bodies Corporate	13,281,985	3.3
Financial Institutions & Others	12,925,890	3.2
NRIs	4,116,292	1.0
Total	398,463,885	100

Industry Highlights



Industry Highlights

Fine quarter for the CV Industry

- Total CV production grew by 13% YoY
- M&HCV production saw a jump of 13% YoY

CV Production: Q3 FY'18 vs. Q3 FY'19

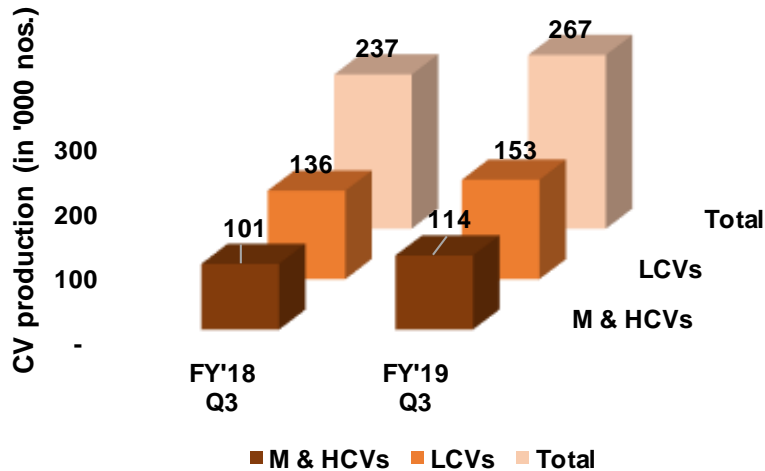

Data Source- SIAM + Internal

Market Share- OEM India

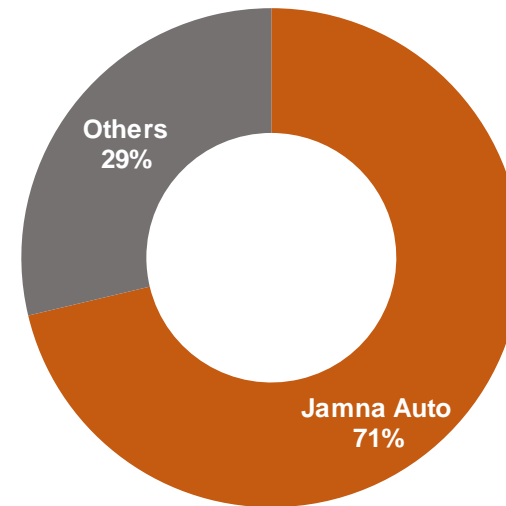

Data Source- Internal

Shift in Global Leaf Spring Market

1980's

Leaf Spring Manufacturer	Base Country	Capacity
NHK Spring Co. Ltd	Japan	200,000
Delphi	USA	100,000
Eaton/Oxford	Canada	100,000
Krupp	Germany	40,000
Hendrickson	USA	40,000
DSP	USA	40,000
Rejna	Europe	40,000
Hoesh	Germany	30,000
Sarfedern	Germany	20,000
Johns Woodhead	UK	10,000

Current

Leaf Spring Manufacturer	Base Country	Capacity
Rassini	Mexico	250,000
Jamna Auto Industries Ltd.	India	240,000
Hendrickson	Canada & Mexico	216,000
NHK Springs Co. Ltd.	Japan & Thailand	150,000
Dong Feng	China	105,000
FAW	China	100,000
MBHA	Spain	60,000
Olgen	Turkey	40,000
LPDN	Europe	26,500

Capacity in Tons per Annum

Financial Updates



Key Financial Trend : Q3 FY'18 Vs. Q3 FY'19

All Figures in Rupees Crore

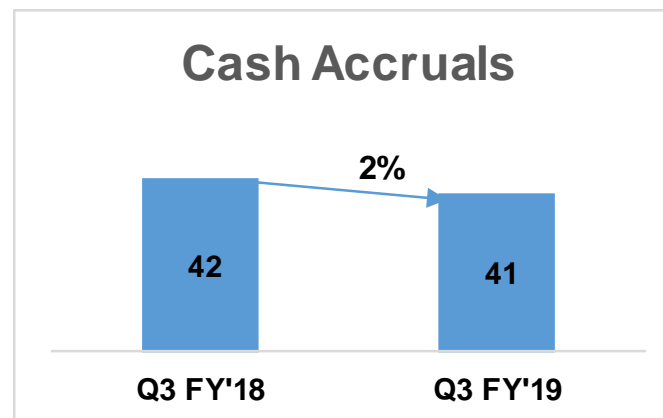
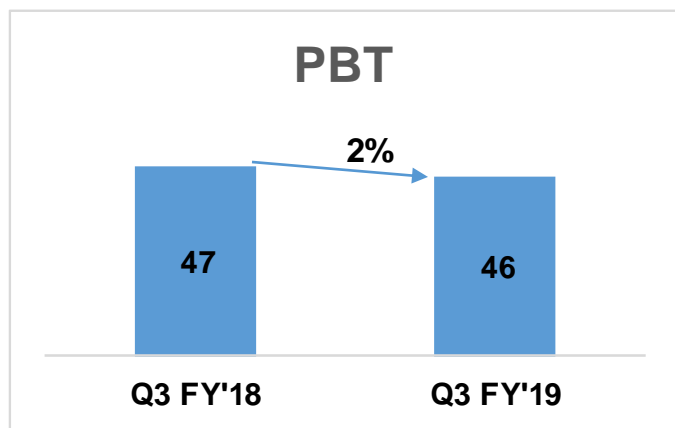
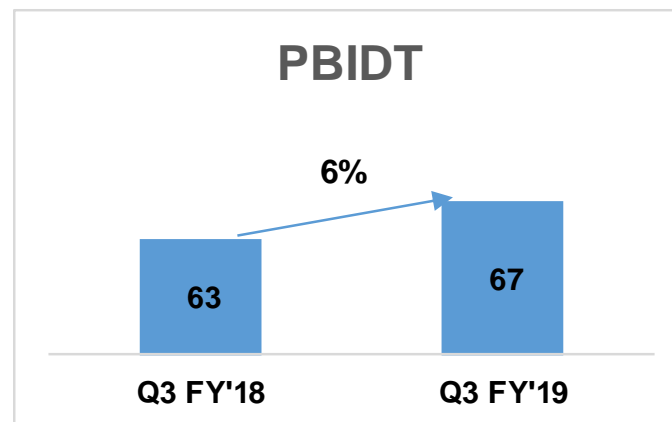
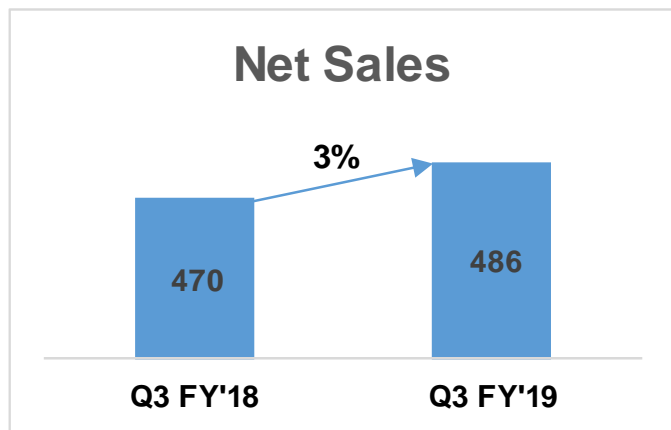

Cash Accruals: PAT+ Depreciation

Financial Results – Q3 FY'19

All Figures in Rupees Crore

Particulars	2017-18	2018-19	2017-18	2018-19	% Growth	% Growth
	12M	Q3	Q3	Q2	Q3 FY'19 Vs Q3 FY'18	Q3 FY'19 Vs Q2 FY'19
Net Sales	1,738.1	486.3	470.3	548.4	3.4%	-11.3%
PBIDTA	245.7	67.1	63.0	71.2	6.5%	-5.7%
Operating Margin	204.3	54.8	53.0	60.7	3.6%	-9.6%
PBT	186.1	46.2	47.1	54.4	-2.0%	-15.1%
PAT	125.3	28.6	31.7	35.5	-10.0%	-19.6%
Cash Accruals	166.7	40.8	41.8	46.0	-2.3%	-11.3%
PBDITA Margin (%)	14.1%	13.8%	13.4%	13.0%	0.4%	0.8%
Operating Margin (%)	11.8%	11.3%	11.3%	11.1%	0.0%	0.2%
PBT (%)	10.7%	9.5%	10.0%	9.9%	-0.5%	-0.4%
PAT (%)	7.2%	5.9%	6.7%	6.5%	-0.9%	-0.6%
Cash Accruals (%)	9.6%	8.4%	8.9%	8.4%	-0.5%	0.0%

Cash Accruals: PAT+ Depreciation

Contributing to Society



Provided **sponsorship** to 63 outstanding sports persons in **Olympic Games**



Adopted ten **Aanganwadi** centers in the collaboration with Women & child department, **Yamunanagar**



Started three new "**Jamna Stitching & Tailoring Centers**" in **Yamuna Nagar & Malanpur**



Distributed woolen to 235 Sr. citizens, widow & PWD"s at **Jamshedpur & Delhi**

Other Achievements made in Q3 FY'19:

Environment: Gifted 800 saplings among employees, community people & truck drivers in Malanpur, Madhya Pradesh

Education: Collaborated with NIIT Foundation for assessment & certification of computer course. Total 58 trainees have been completed their basic CCMO course in 1st quarter & got certificates for NIIT Foundation in Delhi NCR

Sports: Distributed sports equipment to Govt. schools, and Fulwari Centers in Jamshedpur, Yamunanagar, Delhi & District Prison, Gurgaon

Community Outreach: Organized "Food for All" for more than 12000 poor people in Delhi & Yamunanagar; Organized a multispecialty health camp, eye camps in 3 states where more than 200 patients were screened, 44 patients got spectacles, one got cataract surgery

Forward Looking Statement

This presentation is made to enable investors to comprehend our prospects and take informed investment decisions. This presentation may contain certain forward looking statements within the meaning of applicable laws and regulations. We cannot guarantee that these forward-looking statements will be realized, although we believe we have been prudent in assumptions. The achievement of results is subject to risks, uncertainties and even inaccurate assumptions. Should known or unknown risks or uncertainties materialize, or should underlying assumptions prove inaccurate, actual results could vary materially from those anticipated, estimated or projected. Readers should bear this in mind. We undertake no obligation to publicly update any forward-looking statements, whether as a result of new information, future events or otherwise.

Thank You