



Jamna Auto Industries Ltd.

August 13, 2016

BSE Limited
Phiroze Jeejeebhoy Towers,
Dalal Street,
Mumbai – 400 051

Company's Listing Code: 520051

Subject: Presentation on financial results

Dear Sir/Madam,

Pursuant to Clause 30 (2) read with Schedule III Part A of the Securities and Exchange Board of India (Listing Obligations and Disclosure Requirements) Regulations, 2015, please find attached herewith Presentation on financial results for Q1 FY 2016-17.

This is for your information and record.

Thanking you

Yours faithfully,

For Jamna Auto Industries Limited

Praveen Lakhera

Company Secretary & Head-Legal

Corporate Office: 2 Park Lane, Kishan Garh, Vasant Kunj, New Delhi - 110070.

Tele: 91-11-26893331, 26896960, 32648668 | **Fax:** 91-11-26893192 | www.jaispring.com | **CIN:** L35911HR1965PLC004485

Regd Office: Jai Spring Road, Yamuna Nagar (Haryana) - 135 001, India | **Tel:** 91-1732-251810 | **Fax:** 91-1732-251820

YAMUNA NAGAR | MALANPUR | CHENNAI | JAMSHEDPUR | PANTNAGAR | HOSUR | PUNE

Jamna Auto Industries Ltd.

Company Profile

2016-17



Jamna Auto Industries Ltd

Sales

FY 2015-16 = INR 1,256 Cr
Q-1 2016-17 = INR 335 Cr

Market Capitalization

INR 1,400 Cr Approx.
(Share Price INR 174.2/- as on 30.06.16)

Production Spring Capacity

Existing – 180,000 MT

3rd in the World

Alliance

Ridewell (USA) – Air Suspension & Lift Axle

Manufacturing Plants

8 Plants in 6 States

Listed on Stock Exchanges

BSE – 520051
NSE – JAMNAAUTO

Global Spring Manufacturers

Indian Market Scenario

SOB*

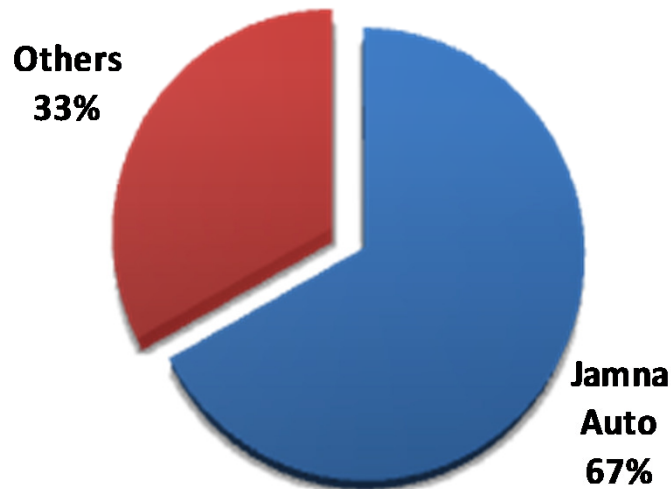

Global Leaf Market Scale

1980's

Leaf Spring Manufacturer	Base Country	Capacity
NHK Spring Co. Ltd.	Japan	2,00,000
Delphi	USA	1,00,000
Eaton/Oxford	Canada	1,00,000
Krupp	Germany	40,000
Hendrickson	USA	40,000
DSP	USA	40,000
Rejna	Europe	40,000
Hoesh	Germany	30,000
Sarfedern	Germany	20,000
Johns Woodhead	UK	10,000

Current

Leaf Spring Manufacturer	Base Country	Capacity
Rassini	Mexico	2,50,000
Hendrickson	Canada & Mexico	1,90,000
Jamna Auto Industries Ltd.	India	1,80,000
NHK Springs Co. Ltd.	Japan & Thailand	1,50,000
Ventanna	Europe	1,10,000
Dong Feng	China	1,05,000
FAW	China	1,00,000
MBHA	Spain	36,000
Olgin	Turkey	28,000
LPDN	Europe	24,000

Note-The data as shown above is for Q1- 2016-17

Data Source- Internal

* SOB-Share of business

Capacity in Tons per Annum

3/17



Shareholding Pattern

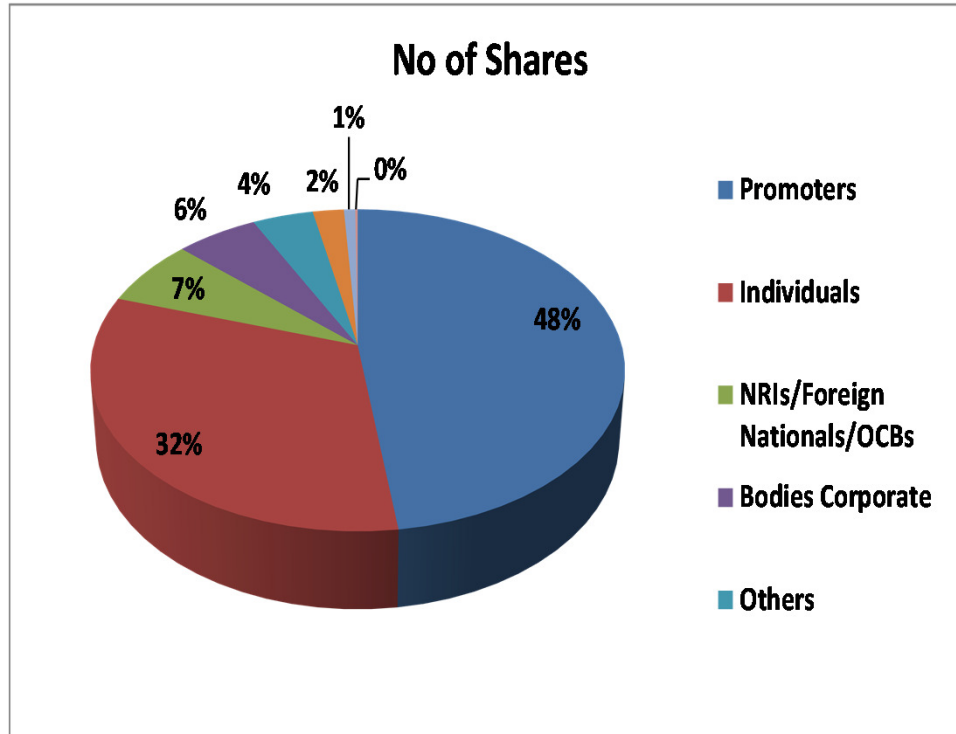

Category	No of shares	Percentage
Promoters	3,81,54,630	48%
Individuals	2,55,60,668	32%
NRIs/Foreign Nationals/OCBs	54,30,415	7%
Bodies Corporate	45,72,360	6%
Others	34,05,757	4%
FIIs	17,43,269	2%
Mutual Funds/UTI	6,34,100	0.8%
Financial Institutions/Banks	1,35,177	0.2%
Total	7,96,36,376	100%

Note- The Shareholding Pattern shown above is as on June 30,,2016

Our Strengths

OEM Market Share 67%

Manufacturing more than 460 Parts for OEMs

Industry Leader in India - nearest competitor with little Market Share

Strategically located all over India

Q-1 FY17 Sales INR 335 Cr & Installed Capacity 180,000 MT p.a.

Products

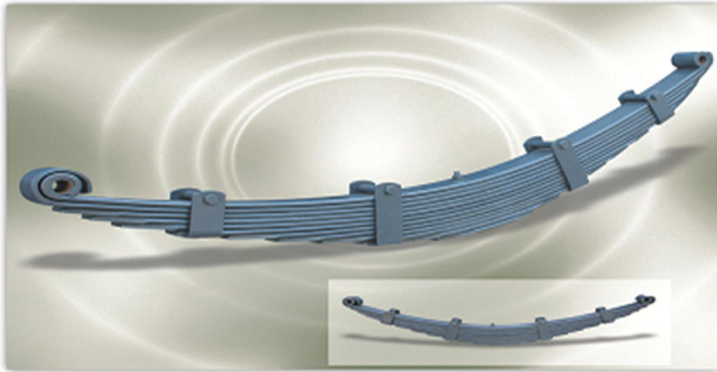

Conventional Leaf spring

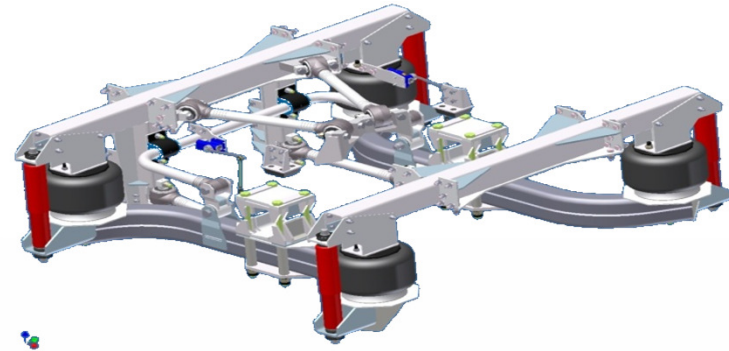

Air Suspension

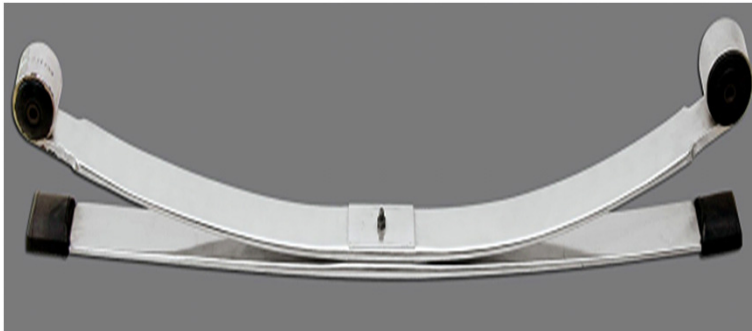

Parabolic Leaf Spring

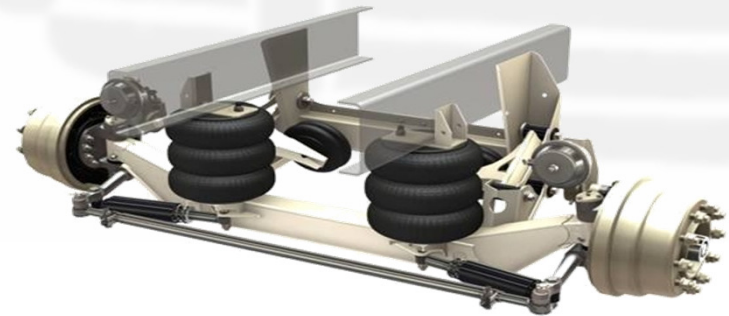

Lift Axle

Presence

Locations

Main Plants

- ❖ Yamuna Nagar
- ❖ Malanpur
- ❖ Chennai:
 - Maraimalai Nagar (Leaf Spring)
 - Pillaipakkam (Lift Axle)
- ❖ Jamshedpur
- ❖ Pune (Plant & R&D Centre)

Assembly Plants

- ❖ Pant Nagar
- ❖ Hosur

8 Locations

Products

- ❖ Leaf Spring
- ❖ Parabolic Spring
- ❖ Lift Axle
- ❖ Air Suspension

4 Products

Markets

- ❖ OE India
- ❖ AM India
- ❖ OE – Exports
- ❖ AM – Exports

4 Markets

* OE India- Original Equipment Manufacturer

* AM India – After Market India

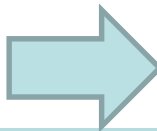

Serving more than 20 OEM Customer Locations in India



7/17



Customers



JAI & OEMs Presence in India

 OEM Plants
 JAI Existing Plants

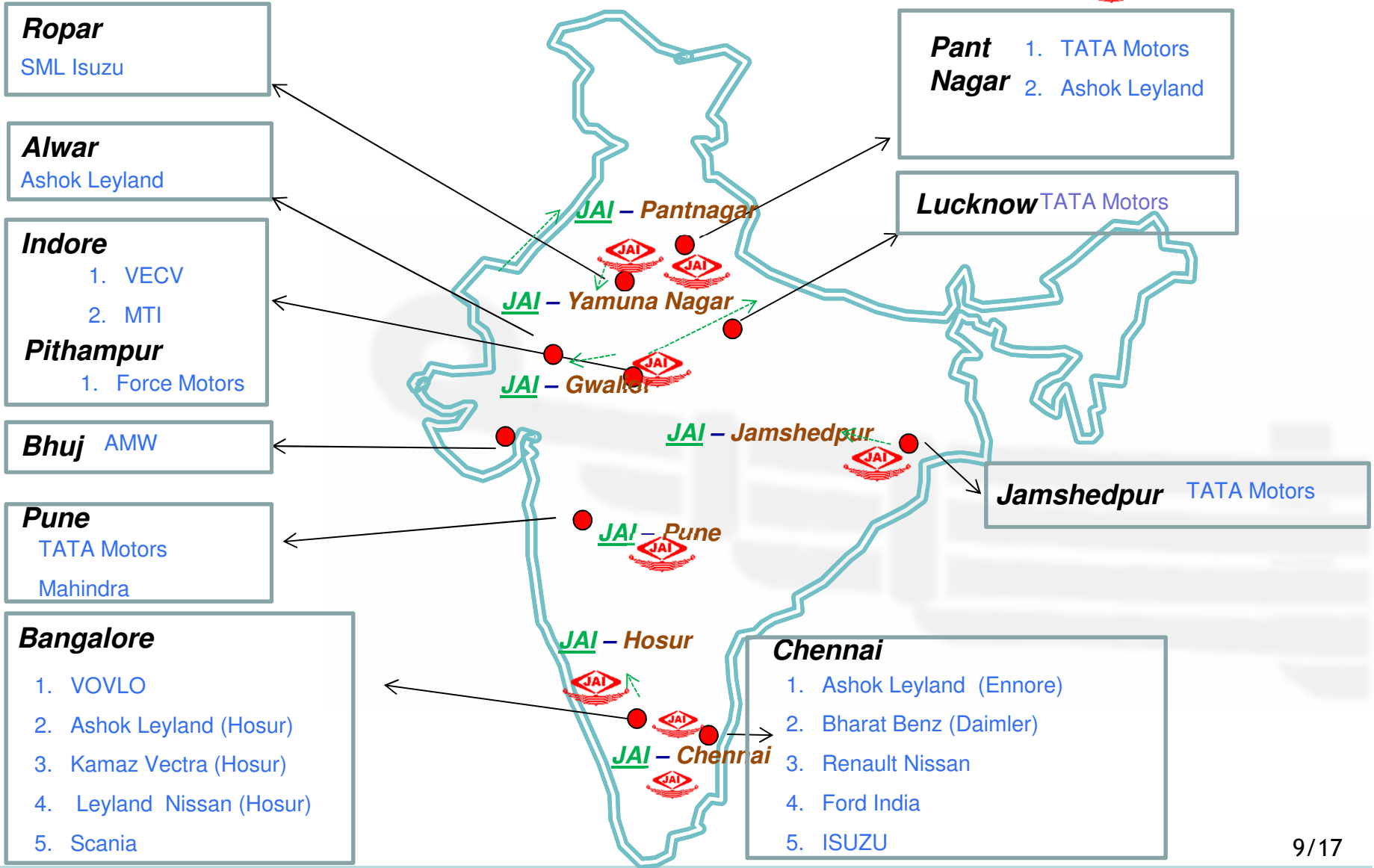

Project Lakshya

Jai's medium term strategy focused on value creation

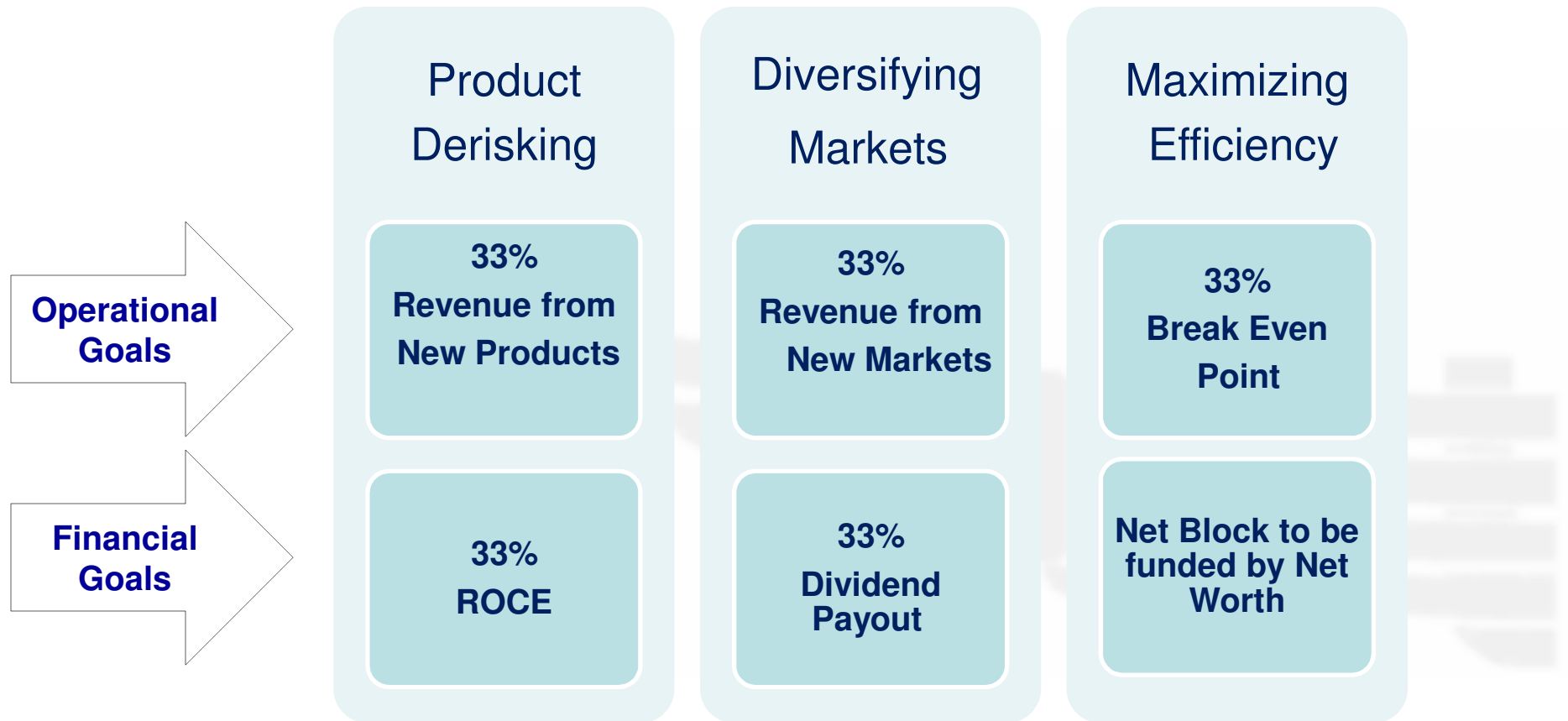

Jamna Auto Industries Ltd

Q1 Update

2016-17

11/17



Financial Results – Q1 FY'17

	<i>INR in Cr</i>			
	2015-16 12m	2015-16 Q1	2016-17 Q1	Growth* in %
Net Sales	1,255.8	290.1	335.1	16%
Export Sales	10.8	2.7	2.5	-8%
EBITDA	164.9	30.2	58.3	93%
Operating Margin	119.7	21.9	40.9	87%
PBT	105.0	18.7	39.4	110%
PAT	71.5	12.8	27.4	114%
Cash Accruals	116.7	21.1	44.8	112%
EBITDA Margin (%)	13.1%	10.4%	17.4%	67%
Operating Margin (%)	9.5%	7.5%	12.2%	62%
PBT (%)	8.4%	6.5%	11.8%	82%
PAT (%)	5.7%	4.4%	8.2%	85%
Cash Accruals	9.3%	7.3%	13.4%	83%

Cash Accruals- PAT + Depreciation

* Growth over Q1 of 2015-16

12/17



Financial Results – Q1 FY'17

- **Sales** Increased by **16%**

- **EBIDTA** **17%** in the quarter

- **ROCE** Improved ROCE to **61%** -maintaining LAKSHAY target as announced in FY14

- **Debt** Maintaining the status of virtual **debt-free**

- **NW=NB** Capital expenditure met out of **internal** cash generation

- **Expansion** Commercial production in third quarter at **Hosur** plant
To set up a plant in **Lucknow**



Financial Highlights – Q1 FY'17

❑ Credit Ratings by ICRA:

- Long Term Rating **AA-**
- Short Term Rating **A1+**

❑ Healthy Liquidity:

As on 30.06.16	* INR in Cr
Unutilized Working Capital Limits (PO Finance & Cash Credit)	50
Unutilized VFS Limits	70
Cash Balance	10
Total available	130



CV Industry & JAI's Journey

	Q-1 2015-16	Q-1 2016-17	Growth in Q-1	Growth in 2015-16
OEMs - Commercial Vehicle Production (Nos.)	1,75,960	2,11,599	20%	12%
JAI 's Net Sale (INR in Crore)	290	335	16%	15%
JAI's Market Share (%)	64	67	5%	3%

Vehicle Production information source : SIAM (i.e adjusted for Diangler India Commercial Vehicles Ltd-DICV)

15/17



Borrowing Trend

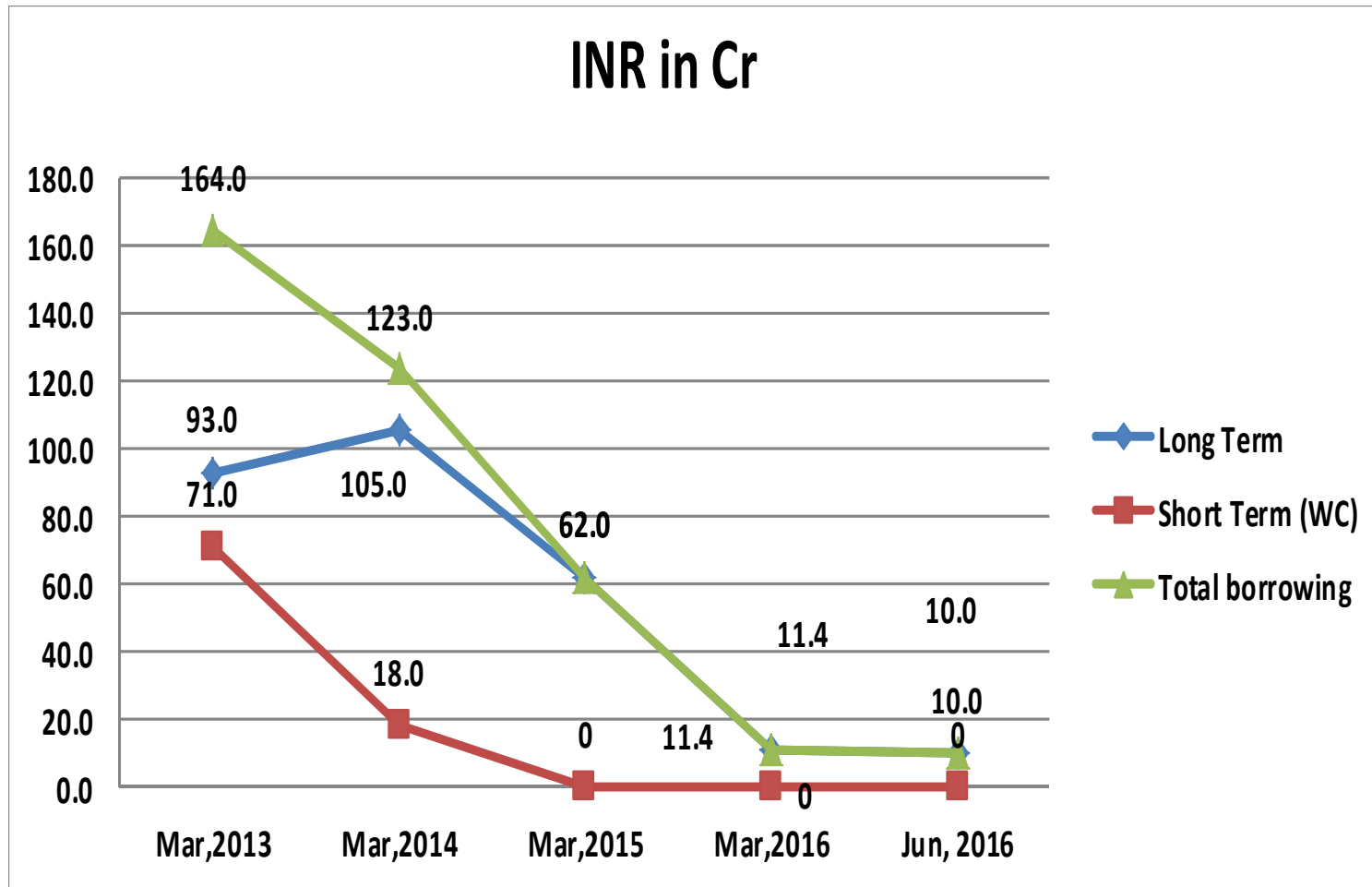

Note: Figures shown above are excluding Vendor Financing Facility.





Thank You