



Jamna Auto Industries Ltd.

14th November, 2017

To,
BSE Limited
Phiroze Jeejeebhoy Towers, Dalal Street,
Mumbai- 400001 Maharashtra

BSE Code: 520051

To,
National Stock Exchange of India Limited
Exchange Plaza, Plot no. C/1, G Block,
Bandra-Kurla Complex, Bandra (E)
Mumbai - 400 051, Maharashtra
NSE Code: JAMNAAUTO

Subject–Presentation on the financial results of second quarter of Financial Year 2017-18

Dear Sir,

Pursuant to the requirements of Regulation 30 and Regulation 46 of SEBI (Listing Obligations & Disclosure Requirements) Regulations, 2015, we are enclosing herewith the presentation by the Company pertaining to the financial results of second quarter of Financial Year 2017-18.

Kindly take the above information on record.

Thanking you,

Yours faithfully,

For Jamna Auto Industries Limited

Praveen Lakhera

Company Secretary & Head-Legal

Encl: As above

Corporate Office: 2 Park Lane, Kishan Garh, Vasant Kunj, New Delhi - 110070.

Tele: 91-11-26893331, 26896960, 32648668 | Fax: 91-11-26893192 | www.jaispring.com | CIN: L35911HR1965PLC004485

Regd Office: Jai Spring Road, Yamuna Nagar (Haryana) - 135-001, India | Tel: 91-1732-251810 | Fax: 91-1732-251820

YAMUNA NAGAR | MALANPUR | CHENNAI | JAMSHEDPUR | PANTNAGAR | HOSUR | PUNE

Staying ahead of the curve...

INVESTOR PRESENTATION Q2 FY 18

Malanpur

Company Overview



**WORLD'S LEADING
PLAYERS IN LEAF SPRING**

Key Highlights

Sales

Q2 FY'18 = INR 385 Crores (~US\$ 60Mn)

Q2 FY'17 = INR 273 Crores (~US\$ 43Mn)

Q-1 2017-18 = INR 271 Crores (~ US\$ 42Mn)

Market Capitalization

~INR 2,100 crores (~ US\$ 325Mn)

(Share Price INR 260* as on 30th Sept.)

Production Capacity - Springs

2,10,000 Tons per annum

Among World's Top 3

Alliance

Ridewell (USA) – Air Suspension & Lift Axle

Plants

9 Plants in 7 States

Listed on Stock Exchange

**BSE – 520051
NSE – JAMNAAUTO**

1\$=~INR 64.29

* Face value INR 5/- per share

Global Spring Manufacturing

Global Leaf Market Scale

Indian Market Scenario

Market Share- OEM India

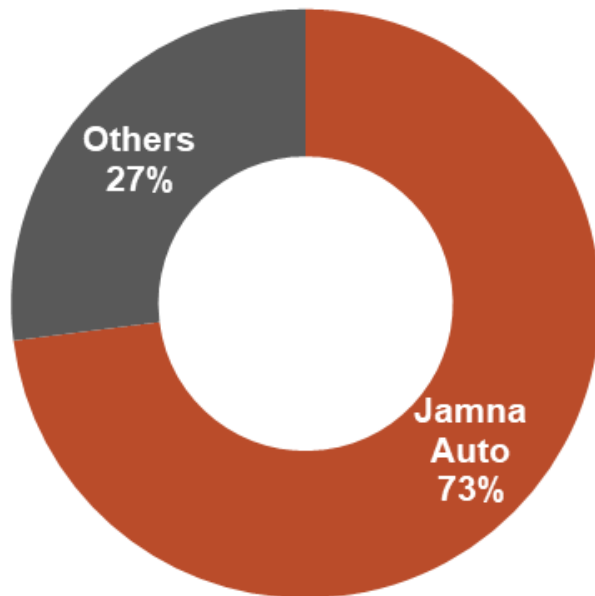

1980's

Leaf Spring Manufacturer	Base Country	Capacity
NHK Spring Co. Ltd	Japan	200,000
Delphi	USA	100,000
Eaton/Oxford	Canada	100,000
Krupp	Germany	40,000
Hendrickson	USA	40,000
DSP	USA	40,000
Rejna	Europe	40,000
Hoesh	Germany	30,000
Sarfedern	Germany	20,000
Johns Woodhead	UK	10,000

Current

Leaf Spring Manufacturer	Base Country	Capacity
Rassini	Mexico	250,000
Hendrickson	Canada & Mexico	216,000
Jamna Auto Industries Ltd.	India	210,000
NHK Springs Co. Ltd.	Japan & Thailand	150,000
Dong Feng	China	105,000
FAW	China	100,000
MBHA	Spain	60,000
Olgen	Turkey	40,000
LPDN	Europe	26,500

Data Source- Internal, Q2 Market Share in terms of Tons

Capacity in Tons per Annum

Shareholding Pattern

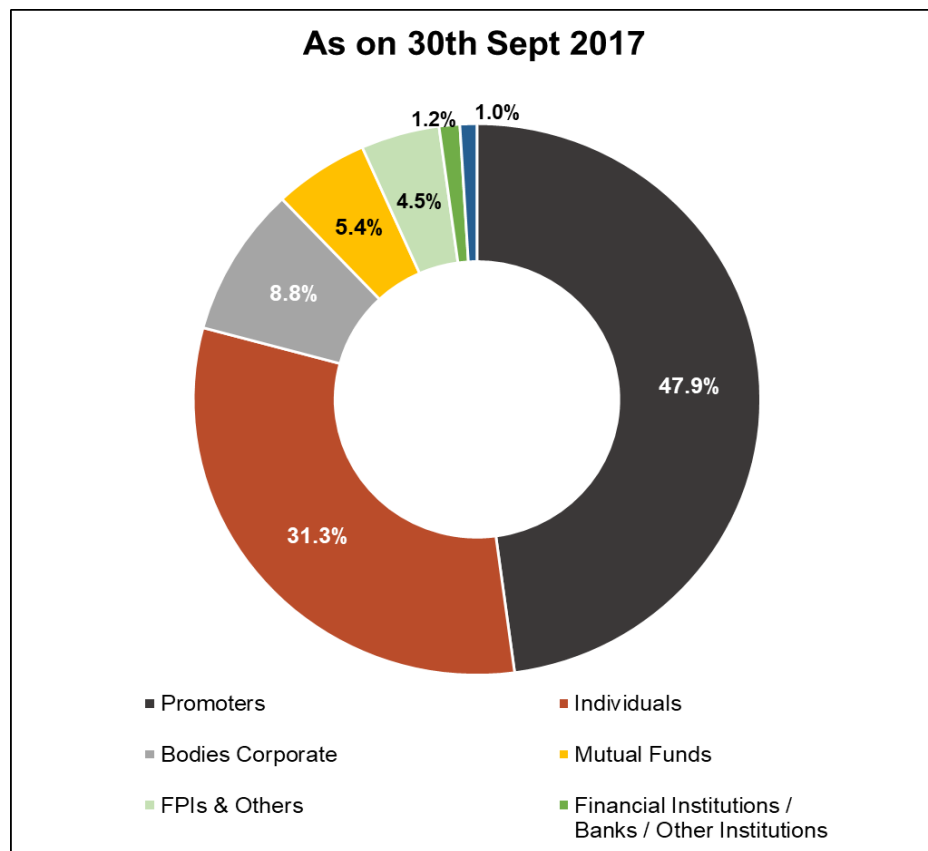

Category	No of shares	In %
Promoters	38,154,630	47.9
Individuals	24,947,035	31.3
Bodies Corporate	6,980,619	8.8
Mutual Funds	4,324,592	5.4
FPIs & Others	3,574,064	4.5
Financial Institutions / Banks / Others	936,358	1.2
NRIs	770,174	1.0
Total	79,687,472	100

Our Strengths

Manufacturing ~ 500 Parts for OEMs & ~2000 parts for After Market

OEM Market Share 73% *(Q2- weighted average)*

Pan India Manufacturing Facilities

Only Company with Spring R & D Centre in India

Strong Credit Rating : Short Term A1+ & Long Term AA- *(ICRA)*

Low Leveraged with Strong Liquidity Position

Diversification Strategy

Locations

MAIN PLANTS

- Yamuna Nagar
- Malanpur
- Chennai:
 - Maraimalai Nagar (Leaf Spring)
 - Pillaipakkam (Lift Axle)
- Jamshedpur
- Pune (Lift Axle & R&D Centre)
- Hosur

ASSEMBLY PLANTS*

- Lucknow
- Pant Nagar

9 Locations

**Under subsidiary entity of Jamna*

Products

- Leaf Spring
- Parabolic Spring
- Lift Axle
- Air Suspension

4 Products

** OE - Original Equipment Manufacturer*

Markets

- OE India
- AM India
- OE – Exports
- AM – Exports

4 Markets

** AM – After Market*

Products

Diversifying Products

1) Conventional Leaf Spring

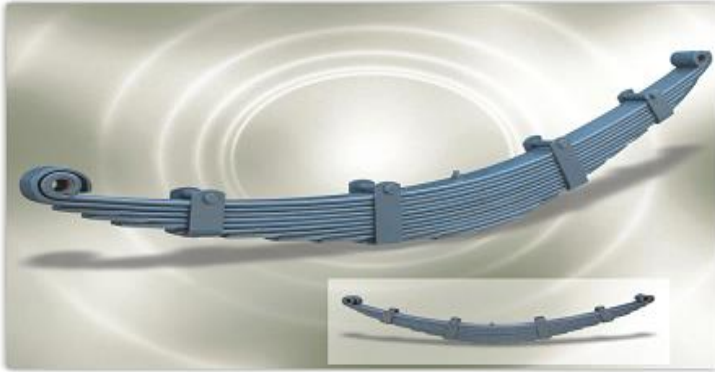

3) Air Suspension

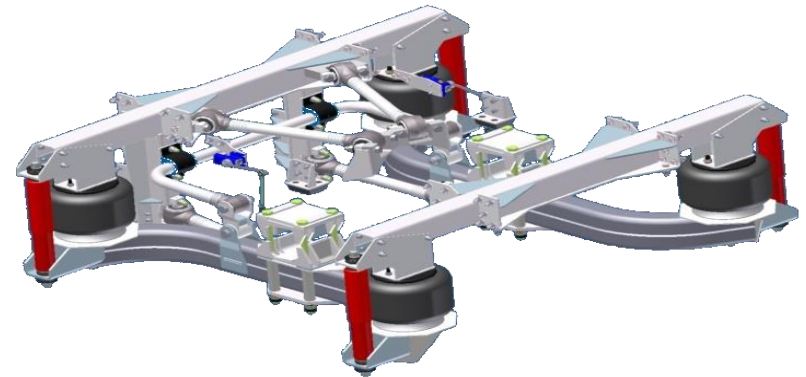

2) Parabolic Leaf Spring



4) Lift Axle



Customers



PAN India Presence

● OEM Plants
● JAI Existing Plants

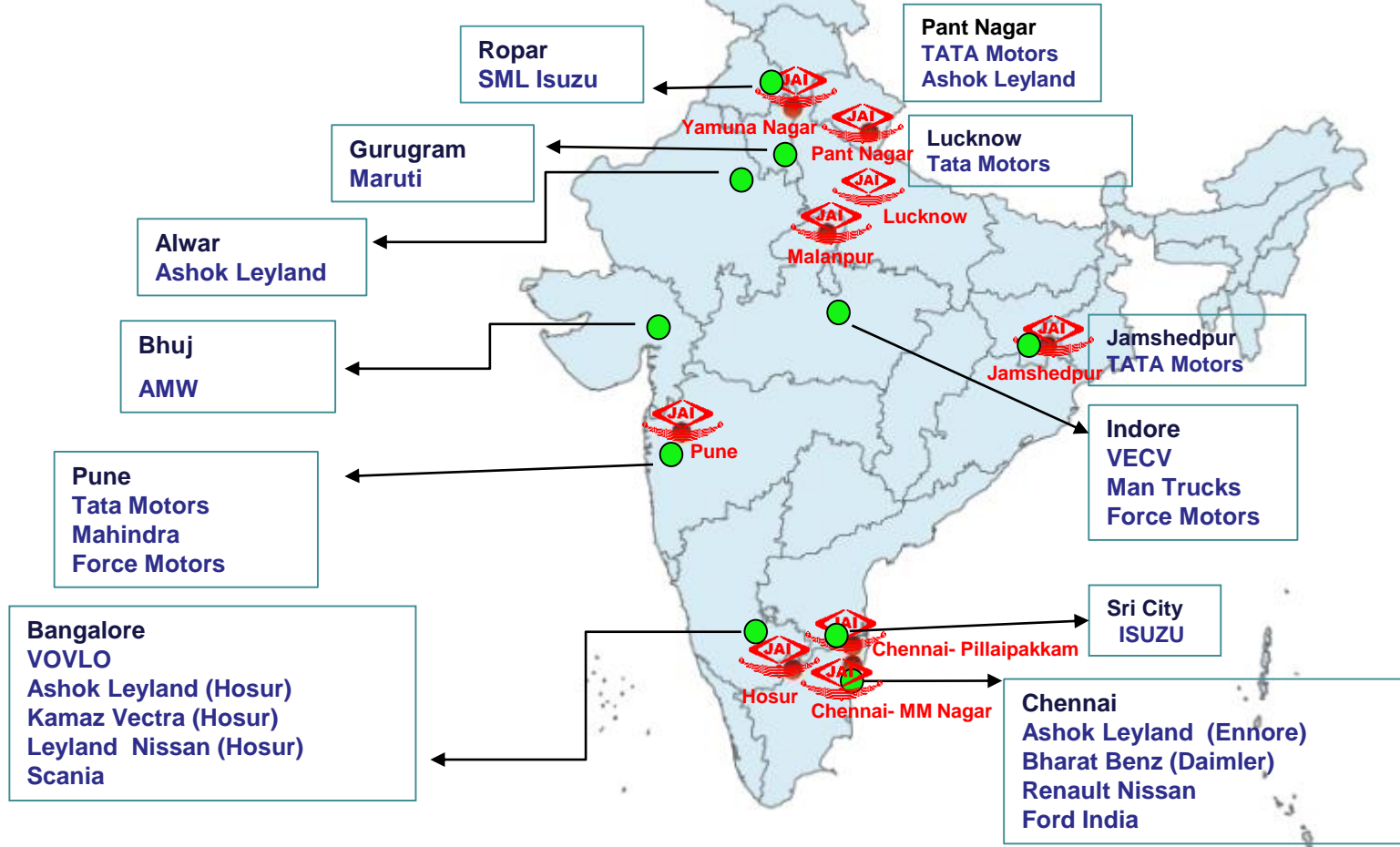

Map Source: as available on www.surveyofindia.gov.in dated 17.02.2017
 The Map is for illustrative purpose only



Project Lakshya

OPERATIONAL GOALS



FINANCIAL GOALS



Lakshya - JAI's Medium Term Strategy focused on **Value Creation**

Q2 FY'18 Updates



FOCUS - INTERNAL EFFICIENCY & PRODUCTIVITY

Jamshedpur

Key Financial Trend

Net Sales

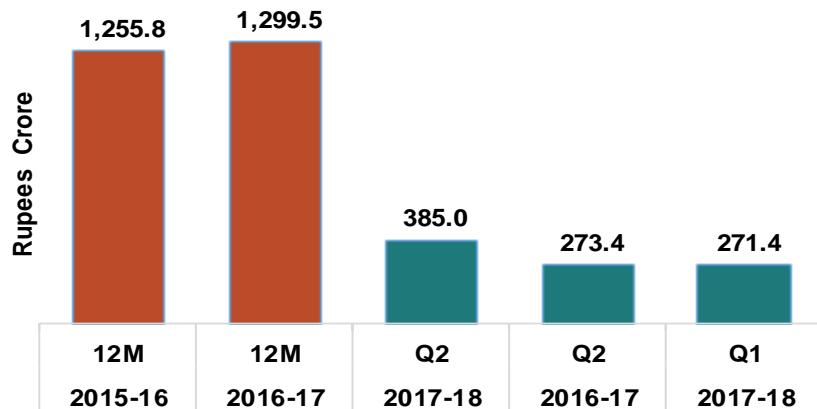

PBT

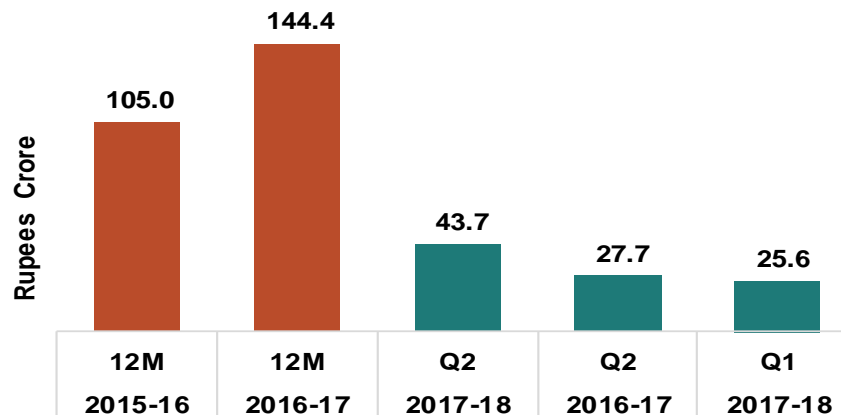

EBDITA

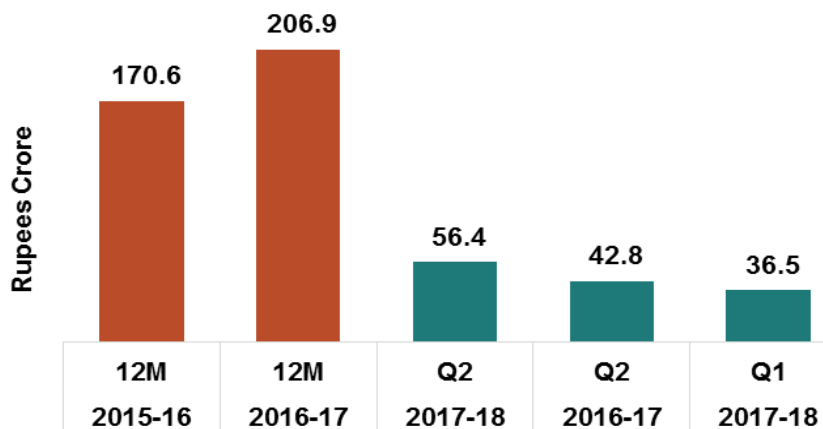

Cash Accruals

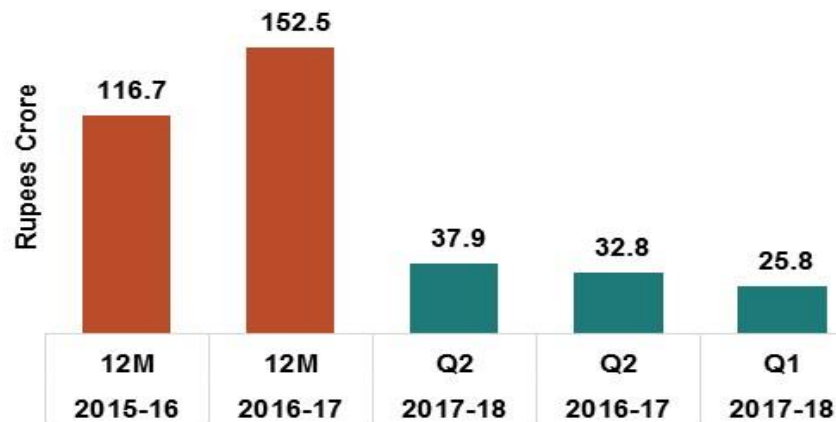

Conversion Rupees 1 Crore = Rupees 10 Million

Financial Results – Q2 FY'18

INR in Crores

Particulars	2015-16	2016-17	2017-18	2016-17	2017-18	% Growth	% Growth
	12M	12M	Q2	Q2	Q1	Q2 FY'18 Vs Q2 FY'17	Q2 FY'18 Vs Q1 FY'18
Total Net Sales	1,255.8	1,299.5	385.0	273.4	271.4	40.8%	41.9%
Export out of above	9.2	9.6	3.2	1.7	2.6	90.0%	24.2%
EBDITA	170.6	206.9	56.4	42.8	36.5	31.8%	54.8%
Operating Margin	125.3	159.1	48.0	31.7	28.1	51.5%	70.9%
PBT	105.0	144.4	43.7	27.7	25.6	57.6%	70.9%
PAT	71.5	104.7	29.4	21.6	17.4	36.1%	69.1%
Cash Accruals	116.7	152.5	37.9	32.8	25.8	15.6%	46.9%
EBDITA Margin (%)	13.6%	15.9%	14.7%	15.7%	13.4%	-1.0%	1.2%
Operating Margin (%)	10.0%	12.2%	12.5%	11.6%	10.3%	0.9%	2.1%
PBT (%)	8.4%	11.1%	11.3%	10.1%	9.4%	1.2%	1.9%
PAT (%)	5.7%	8.1%	7.6%	7.9%	6.4%	-0.3%	1.2%
Cash Accruals (%)	9.3%	11.7%	9.8%	12.0%	9.5%	-2.1%	0.3%

Cash Accruals= PAT + Depreciation

CSR Initiatives



Eye Check-up Camp, Yamunanagar



Sensitized almost 1150 students on oral hygiene in Govt. schools, Jamshedpur



Tree Planation Drive



Gifted Computers, Furniture, Lab Equipment to schools



Distributed Sports Equipment to Students in Govt. Schools & Colleges



Sponsored Sports Person- Mr. Parveen Kumar who participated in Fencing Championship in World University Games in China



Scholarship to 73 sports person to support their diet, coaching, equipment & boarding & lodging at national & International Level



Promoted personal hygiene among rural girls by gifting Sanitary Napkin vending machine and incinerator in GNK Institute, Yamunanagar



Conducted "Art of Thinking" sessions for Senior Citizens, Gurugram



Sensitized beneficiaries on waste management & cleanliness issue by organizing Nukkad Natak in Malanpur



Distributing Pension to Needy



Gifted Books to School Children.

Forward Looking Statement



This presentation is made to enable investors to comprehend our prospects and take informed investment decisions. This presentation may contain certain forward looking statements within the meaning of applicable laws and regulations. We cannot guarantee that these forward-looking statements will be realized, although we believe we have been prudent in assumptions. The achievement of results is subject to risks, uncertainties and even inaccurate assumptions. Should known or unknown risks or uncertainties materialize, or should underlying assumptions prove inaccurate, actual results could vary materially from those anticipated, estimated or projected. Readers should bear this in mind. We undertake no obligation to publicly update any forward-looking statements, whether as a result of new information, future events or otherwise.

Thank You