

BEDMUTHA INDUSTRIES LIMITED



CIN - L 31200MH1990PLC057863
MANUFACTURER & EXPORTER OF



★ ALL TYPES OF GALVANISED WIRES & BLACK WIRES

- | | | |
|---------------------------------|---------------------------------|-----------------------|
| ★ ACSR CORE WIRES | ★ SPRING STEEL WIRES | ★ BARBED WIRE |
| ★ CABLE ARMOURING WIRE & STRIPS | ★ ROLLING QUALITY WIRES | ★ CHAIN LINK FENCINGS |
| ★ STAY WIRES & EARTH WIRES | ★ P.C. WIRE & P.C. STRAND WIRES | ★ WIRE NAILS |
| ★ M.S. & H.B. WIRES | ★ ROPE WIRES | ★ BINDING WIRES |

Date: 25/09/2018

To
Department of Corporate Services,
BSE Ltd
Phiroj Jeejibhoy Towers, Dalal Street,
Mumbai – 400 001

To
Listing Department,
National Stock Exchange of India Limited
C-1, G-Block, Bandra-Kurla Complex,
Bandra (E), Mumbai – 400 0051

Scrip Code: 533270, Scrip Symbol: BEDMUTHA

Dear Sir / Madam,

Sub: Disclosure pursuant to Regulation 30 of the SEBI (Listing Obligations and Disclosure Requirements) Regulations, 2015

Please find enclosed herewith the Presentation given by Mr. Ajay Vedmutha, Managing Director of the Company, at the Annual General Meeting held on 25th September 2018.

Kindly take the same on your record.

Thanking you.

For and on behalf of
BEDMUTHA INDUSTRIES LIMITED

AJAY TOPALE

Company Secretary & Compliance Officer
Membership No. A26935



Place: Sinnar

Date: 25th September, 2018



Welcome To
BEDMUTHA INDUSTRIES LIMITED
AGM



PROJECT BASIC INFO: The Master Plan

BEDMUTHA INDUSTRIES LIMITED



QUALITY ASSURED



THE LAND DEVELOPMENT : AT PLOT E-1



THE JOURNEY: STATUS 2017



BUSINESS EXCELLENCE PLAN

NARDANA COMPLEX

QUALITY ASSURED

2021

2018



2017



2015

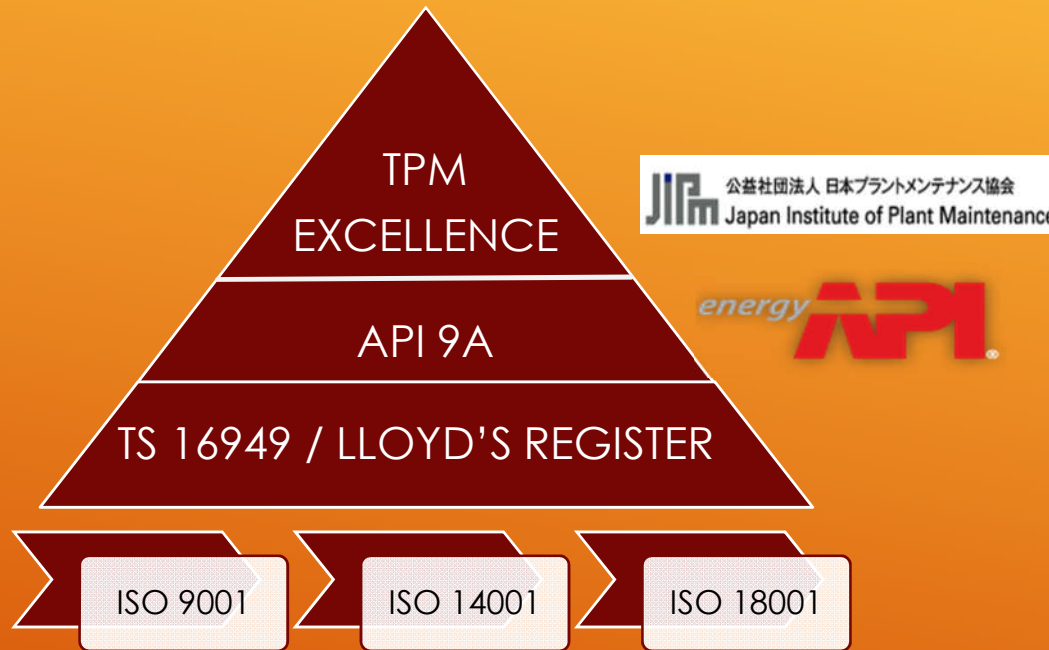

ISO 9001 / 14001 / BS OHSAS 18001 : TUV NORD

BEDMUTHA INDUSTRIES LIMITED

QS: IMS ACCREDITATION 2015



QUALITY ASSURED



QS ACCREDITATIONS

LLOYD'S REGISTER FOR WIRE ROPES

QUALITY ASSURED



Certificate No : MD00/4678/0001/11

BEDMUTHA INDUSTRIES LTD
Plot No. B-1, Nardana MIDC, Phase-2
Waghadi Khurd, Taluka-Sindekheda,
Dist-Dhule
India

has been approved as a manufacturer in accordance with the requirements of Lloyd's Register for :-

Steel Wire Rope
(maximum 40 mm diameter)

This approval is subject to compliance with the Rules for the Manufacture, Testing and Certification of Materials.

Lloyd's Register is to be notified of any change that may affect the validity of this Certificate.

This Certificate is issued to the above manufacturer and is valid until the date given below.

Valid Until : 30 April 2020
Date of Issue : 01 May 2017

Lili Hou
Senior Specialist to Lloyd's Register EMEA
A member of the Lloyd's Register group

A member of the Lloyd's Register group. Lloyd's Register Group Limited, its affiliates and subsidiaries and their respective officers, employees or agents are, individually and collectively, referred to in this clause as 'Lloyd's Register'. Lloyd's Register assumes no responsibility and shall not be liable to any person for any loss, damage or expense caused by reliance on the information or advice in this document or howsoever provided, unless that person has signed a contract with the relevant Lloyd's Register entity for the provision of this information or advice and in that case any responsibility or liability is exclusively on the terms and conditions set out in that contract.



ISO / TS : 16949 : 2009 : TUV NORD

BEDMUTHA INDUSTRIES LIMITED

QS: IMS ACCREDITATIONS 2017



QUALITY ASSURED



PRODUCTION CAPACITY :

BEDMUTHA INDUSTRIES LIMITED

**NARDANA COMPLEX
INSTALLED CAPACITY**

88,200 MTPA (NARDANA COMPLEX)
(1,200 CRORE TURN OVER @ 100% UTILISATION)
(180 MILLION USD)

STEEL: 72,000 MTPA (FERROUS)
62,000 MTPA WIRES
10,000 MTPA ROPE

COPPER: 16,200 MTPA (ROD/FLAT/FOIL/WIRE)
14,700 MTPA : ROD/FLAT/WIRE
1,500 MTPA : FOIL

P

QUALITY ASSURED



PRODUCTION CAPACITY :

BEDMUTHA INDUSTRIES LIMITED

SINNAR COMPLEX
INSTALLED CAPACITY

STEEL: 24,000 MTPA WIRES

P

QUALITY ASSURED



KONFORM : 350 / 400

BEDMUTHA INDUSTRIES LIMITED



QUALITY ASSURED



DRAW BENCH / STRAIGHTENER:

BEDMUTHA INDUSTRIES LIMITED



QUALITY ASSURED



STRIP/ TAPE / FOIL MILL

BEDMUTHA INDUSTRIES LIMITED

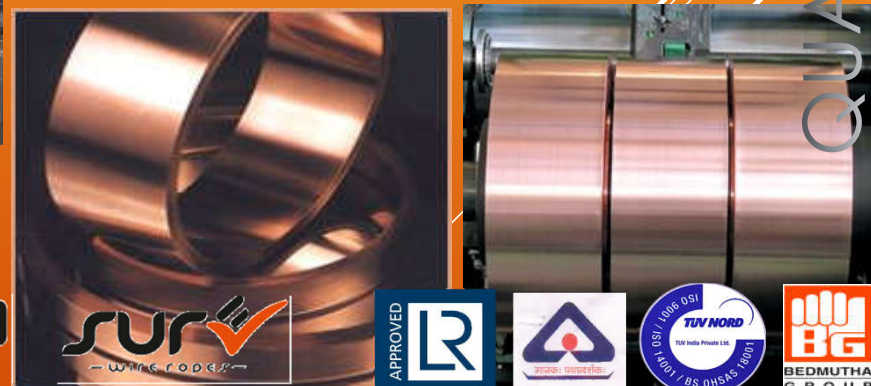

COMMANDO
Wires & Wire Products

SUR
WIRE CODES

APPROVED
LR

WIRE
WIRE

ISO 9001 / 14001
TUV NORD
INDIA PRIVATE LTD.
BS 05454 : 2007

BG
BEDMUTHA
GROUP

QUALITY ASSURANCE

COPPER WIRE : RBD

BEDMUTHA INDUSTRIES LIMITED

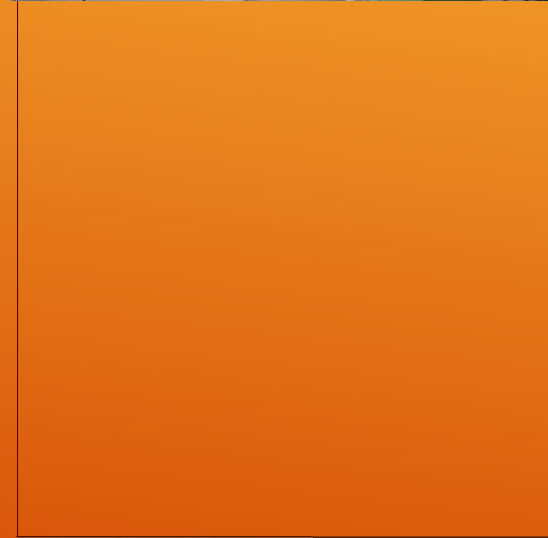

QUALITY ASSURED



COPPER WIRE : MULTI WIRE DRAW / BUNCHING

BEDMUTHA INDUSTRIES LIMITED

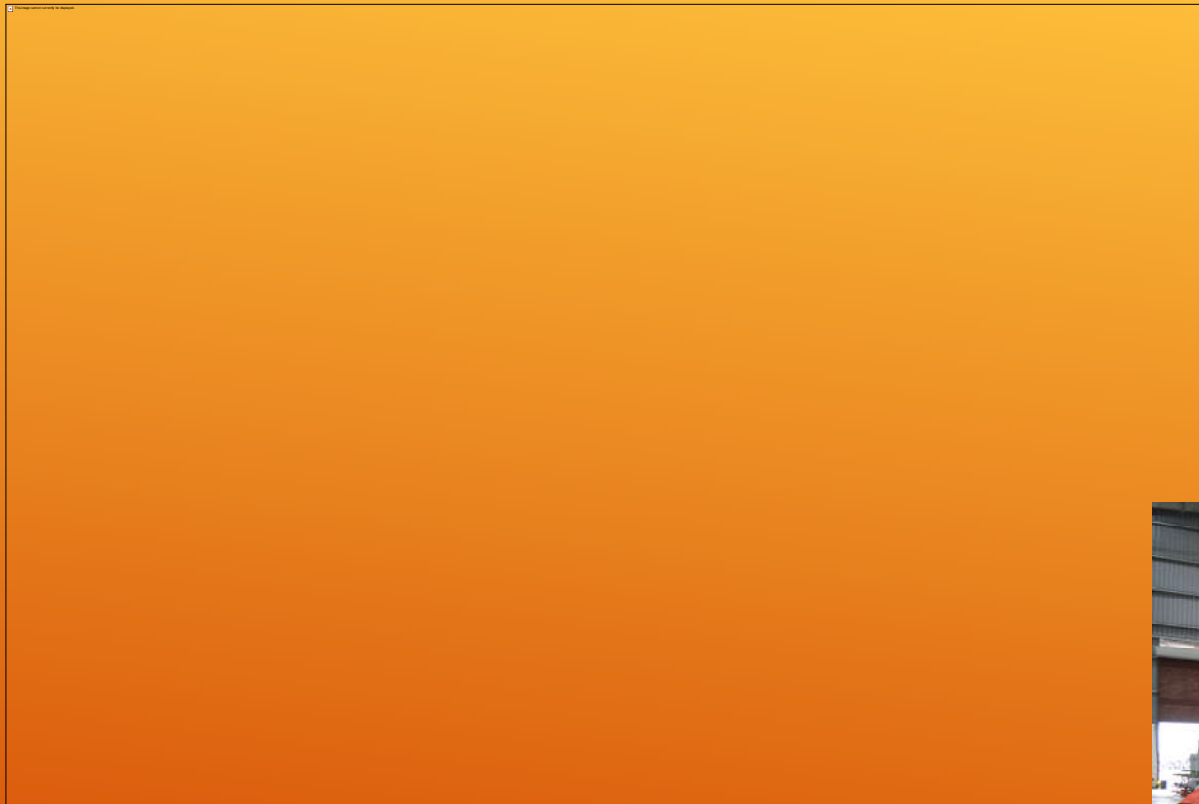

QUALITY ASSURED



COMMANDO
Wires & Wire Products



COPPER WIRE : PLASTICATION LINE

BEDMUTHA INDUSTRIES LIMITED



QUALITY ASSURED





COMMANDO

Wires & Wire Products

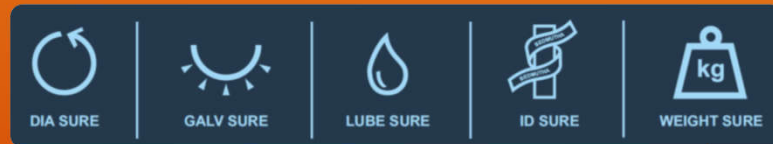

QUALITY ASSURED

BIS CERTIFICATIONS



BEDMUTHA INDUSTRIES LIMITED

QUALITY ASSURED

भारतीय मानक ब्यूरो
BUREAU OF INDIAN STANDARDS

Address: Manak Bhavan, 91, Market Street, Anna Salai, Chennai 600 002
Phone: 022-23232001, 23232002
Fax: 022-2324 8197
E-mail: bis@bis.org.in
Web: http://www.bis.org.in

WESTERN REGIONAL OFFICE
MUMBAI (MUM)

ATTACHMENT TO LICENCE NO. CML- 7700071310

CM.LNO	NAME OF THE LICENSEE WITH ADDRESS	PRODUCT	IS NO.
7700071310	BEDMUTHA INDUSTRIES LIMITED S.I. NARDANA MED. PHASE-2 WALSADI-KHARAD, SHIRDIKINDEGA DIST. CHITRA, 425 504 MAHARASHTRA	STEEL WIRE ROPES FOR GENERAL ENGINEERING PURPOSES	IS 2266:2012

ENDORSEMENT NO. 02 Dated 22-04-2017

The following additional varieties have been included in Column(2) of the first schedule and column (1) of the Second Schedule of the Licence alongwith the Standard Mark in Column (1) of First Schedule with immediate effect.

Size Range - from 8 to 52 mm, Type - Round, Tenile Grade- 1570, 1770, 1960, Core-Steel core IWRC & IWRC Coating - Galvanized and Unplated

Other terms and conditions of Licence remain the same.

(PAWAN KUMAR KANSODI)
Scheme - E & BEAD

भारतीय मानक ब्यूरो
BUREAU OF INDIAN STANDARDS

Address: Manak Bhavan, 91, Market Street, Anna Salai, Chennai 600 002
Phone: 022-23232001, 23232002
Fax: 022-2324 8197
E-mail: bis@bis.org.in
Web: http://www.bis.org.in

WESTERN REGIONAL OFFICE
MUMBAI (MUM)

ATTACHMENT TO LICENCE NO. CML- 7700106412

Our Ref: CML-7700106412

Subject: Grant of BIS Certification Marka Licence No. CML-7700106412 as per IS 4521: 2001

BEDMUTHA INDUSTRIES LTD,
S.I. NARDANA MED. PHASE-2,
WALSADI-KHARAD, SHIRDIKINDEGA
DIST. CHITRA, 425 504
MAHARASHTRA

Dear Sir,

With reference to your application, we are pleased to inform you that it has been decided to grant you a licence to use the Standard Mark in respect of the following:

Product: Wire Ropes Used in Oil Wells and Oil Well Drilling - Specification

IS No: IS 4521: 2001

Type/Size/Grade/Variety covered under licence:
Tenile designation - 1770 Nxtent & 1770 Nxtent, size - 13mm to 40mm, Steel core, Unplated/Uncoated.

2. The number assigned to this licence is CML- 7700106412 which has been made operative from 27/02/2017 and is valid upto 26/02/2018. The licence number should invariably be referred to in your future correspondence.

3. According to sub-regulation (2) of Regulation 6 of Bureau of Indian Standards (Certification) Regulation, 1988, the licence fee of Rs. 1000/- and the marking fee of Rs. 4000.00 as stipulated in the Second Schedule of the licence is payable by you with effect from 27/02/2017 for the period of validity of the licence. Service fee as applicable shall also be charged.

4. Minimum marking for stipulated items is payable by you regardless of the whether you actually mark your product or not with the Standard Mark. Our Receipt No. 7722589 dated 27/02/2017 for the marking fee shall be valid for the period of validity of the licence. The marking fee shall be payable by you with effect from 27/02/2017 for the period of validity of the licence. Service fee as applicable shall also be charged.

5. This licence entitles marking the well be carried over to the next year on every renewal. The actual marking fee as stipulated in the Second Schedule of the licence shall be payable by you with effect from 27/02/2017 for the period of validity of the licence. Service fee as applicable shall also be charged.

भारतीय मानक ब्यूरो
BUREAU OF INDIAN STANDARDS

Address: Manak Bhavan, 91, Market Street, Anna Salai, Chennai 600 002
Phone: 022-23232001, 23232002
Fax: 022-2324 8197
E-mail: bis@bis.org.in
Web: http://www.bis.org.in

WESTERN REGIONAL OFFICE
MUMBAI (MUM)

ATTACHMENT TO LICENCE NO. CML- 7700071310

Our Ref: CML-7700071310

Subject: Grant of BIS Certification Marka Licence No. CML-7700071310 as per IS 2266: 2012

BEDMUTHA INDUSTRIES LTD,
S.I. NARDANA MED. PHASE-2,
WALSADI-KHARAD, SHIRDIKINDEGA
DIST. CHITRA, 425 504
MAHARASHTRA

Dear Sir,

With reference to your application, we are pleased to inform you that it has been decided to grant you a licence to use the Standard Mark in respect of the following:

Product: Steel Wire Suspension Ropes for Lifts, Elevators and Hoists

IS No: IS 2266: 2012

Type/Size/Grade/Variety covered under licence:
Tenile designation upto 1770 Nxtent, size from 20 mm, fibre core/steel and 3rd Nxtent Fibres, Unplated/Uncoated.

2. The number assigned to this licence is CML- 7700071310 which has been made operative from 27/02/2017 and is valid upto 26/02/2018. The licence number should invariably be referred to in your future correspondence.

3. According to sub-regulation (2) of Regulation 6 of Bureau of Indian Standards (Certification) Regulation, 1988, the licence fee of Rs. 1000/- and the marking fee of Rs. 4000.00 as stipulated in the Second Schedule of the licence is payable by you with effect from 27/02/2017 for the period of validity of the licence. Service fee as applicable shall also be charged.

4. Minimum marking for stipulated items is payable by you regardless of the whether you actually mark your product or not with the Standard Mark. Our Receipt No. 7722589 dated 27/02/2017 for the marking fee shall be valid for the period of validity of the licence. The marking fee shall be payable by you with effect from 27/02/2017 for the period of validity of the licence. Service fee as applicable shall also be charged.

5. This licence entitles marking the well be carried over to the next year on every renewal. The actual marking fee as stipulated in the Second Schedule of the licence shall be payable by you with effect from 27/02/2017 for the period of validity of the licence. Service fee as applicable shall also be charged.

IS: 2266
(ROPE IWRC UPTO
52 MM)



IS: 2365
(ELEVATOR ROPE
UPTO 20 MM)



IS: 4521
(OIL WELL ROPE
IWRC UPTO 40 MM)



PRODUCT DESIGN

Our product is well designed with design software from renowned source, experience of best rope manufacturers technical heads and our own team, which is highly experienced in field of steel wire ropes. Thus, design parameters are tested with comprehensive testing in quality laboratory, which supports the ultimate rope performance parameters like breaking force, rotation resistance, fatigue, MOE etc. This makes our ropes world class product with guaranteed performance.

Dura FORM® and Dura FLEX® are our brand for compacted and higher flexibility rope products in various segments. Fatigue and Bend test of ropes: We are testing all wire for bending and SPC techniques are used for validating designs and practical values of wire, strand, rope. Further, all batches are tested for fatigue and since fatigue plays vital role in wire ropes the testing is comprehensive and monitored with strict controls. PRE-STRETCHING FACILITY: We produce best ropes with inline pre-stretching arrangement in line with our closing machine. This can pre-stretch the ropes up to 24 mm diameter in line. Pre-stretching is a specialized process opted for removing the constructional stretch from the rope. This stretch is permanent in nature. The inline method of removing stretch is reliable and efficient as rope is not handled multiple times, as it is done in off-line PS beds. Thus, we offer better rope to our customers!! In effective way.

QUALITY ASSURED



THE QUALITY APPROACH :

QUALITY ASSURANCE FACILITY



We have a fully equipped laboratory to monitor and maintain a well-defined quality assurance system, which tracks and tests steel at every stage right from rod stage tests like physical testing, metallurgical testing and chemical testing, the Lab is well equipped with spectrometer for checking the rod composition. Lab is manned by professionally qualified highly experienced technical team comprising of metallurgists and chemical graduates. The team is always guided by some of the world's best technical experts and developments/process are accordingly validated with all test records. Besides this, all equipment are selected from world's best makers like:

1. Spectrometer from Shimadzu, Japan
2. Tensile testing machine from Shimadzu, Japan
3. Tensile testing machine from Zwick, Germany
4. Wire bend test machine from Zwick, Germany
5. Rope testing machine 300Tf South Asia

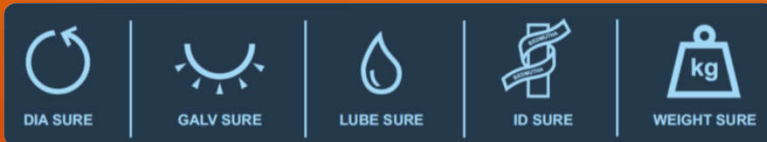

BEDMUTHA INDUSTRIES LIMITED



Q
QUALITY ASSURED

QUALITY LAB



BEDMUTHA INDUSTRIES LIMITED

TYRE BEAD WIRE LINE

TYRE BEAD WIRE LINE:
(2200 MTPM CAPACITY)
Phase-1: 800 MTPM
Start Of Production: 01/08/2017



COMMANDO
Wires & Wire Products

SUR
WIRE ROPE



P
QUALITY ASSURED

BEDMUTHA INDUSTRIES LIMITED

TYRE BEAD WIRE LINE



P

QUALITY ASSURED



COMMANDO
Wires & Wire Products

SUR
WIRE ROPE





P
QUALITY ASSURED

COMMANDO
Wires & Wire Products

SUR
-wire ropes-

APPROVED
LR

ASIAN
INDUSTRIES

ISO 9001 / 10000 PSI
TUV NORD
TUV India Private Ltd.
BS 04581 / BS 04585 / 18001

BG
BEDMUTHA
GROUP

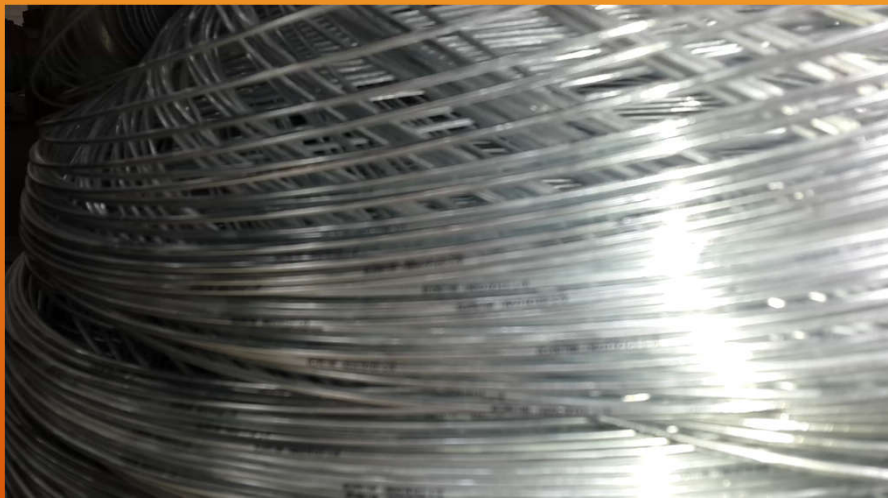

QUALITY ASSURED





P

QUALITY ASSURED





P

QUALITY ASSURED





QUALITY ASSURED



BEDMUTHA INDUSTRIES LIMITED

WIRE ROPE

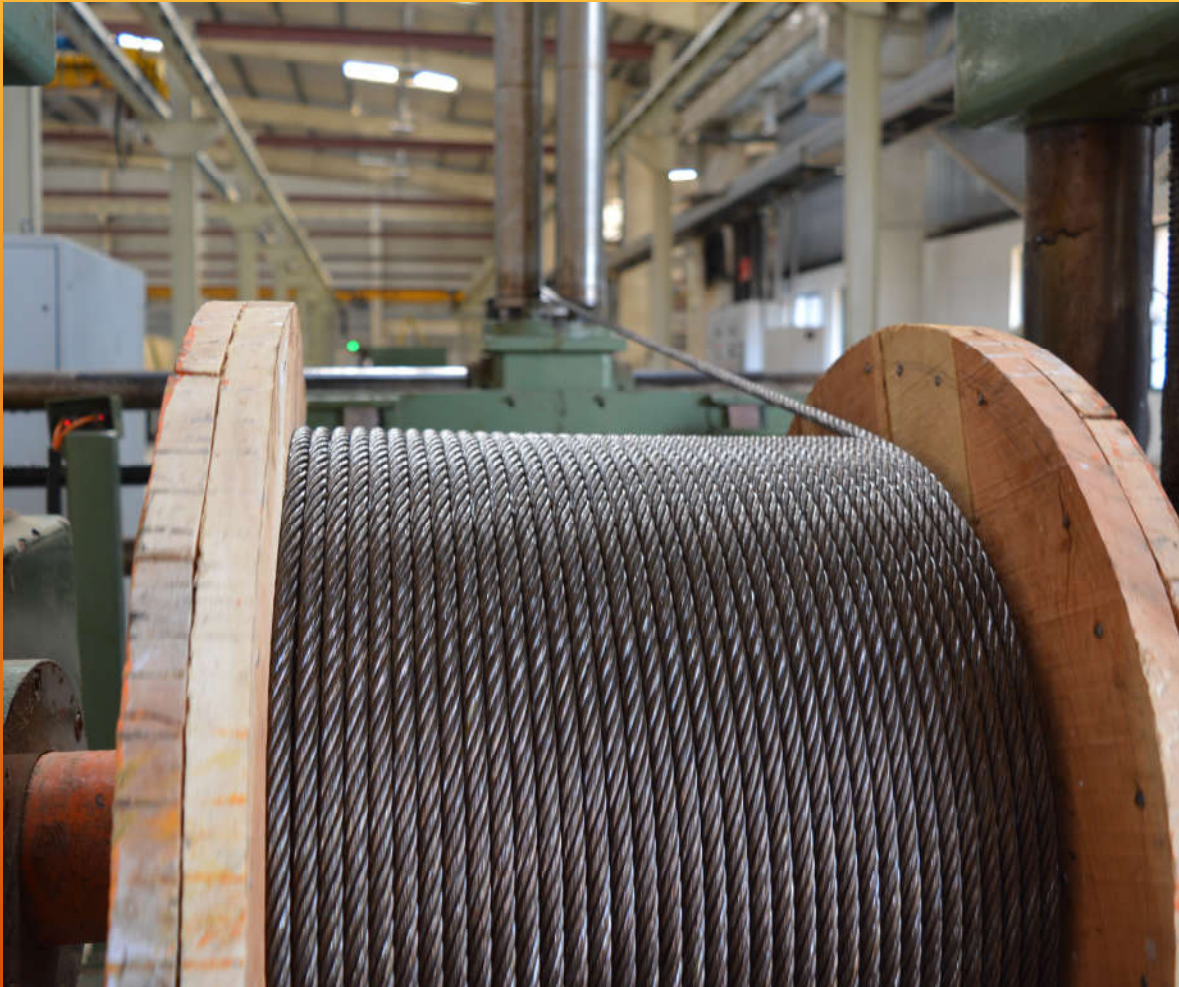

QUALITY ASSURED

COMMANDO
Wires & Wire Products

sur
-wire ropes-

APPROVED
LR

sur
-wire ropes-

TUV NORD
ISO 9001 / 14001 / BS OHSAS 18001

BG
BEDMUTHA
GROUP

ETP : ZERO LIQUID DISCHARGE APPROACH

BEDMUTHA INDUSTRIES LIMITED

ENVIRONMENT



QUALITY ASSURED



ZLD : ZERO LIQUID DISCHARGE APPROACH

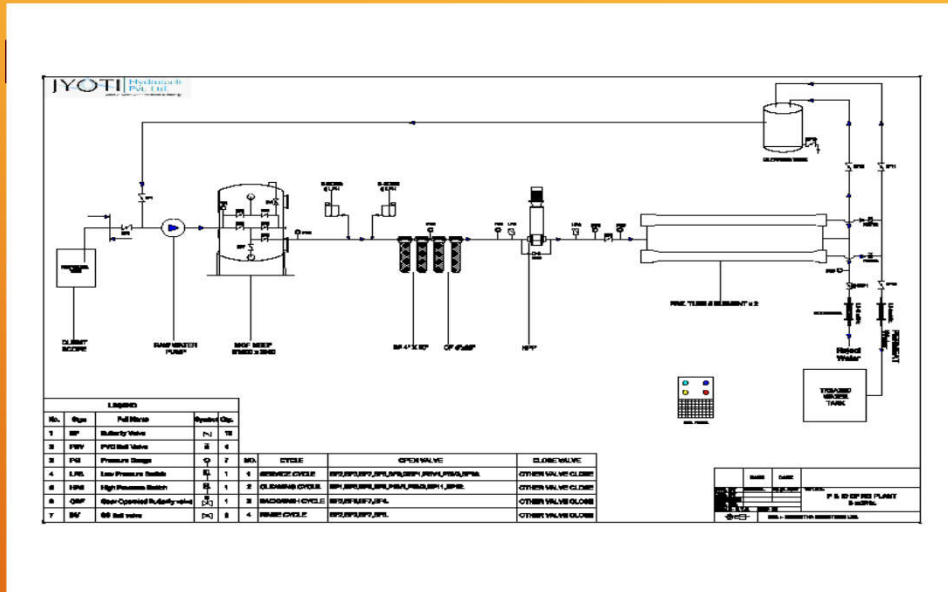

QUALITY ASSURED

ZLD : ZERO LIQUID DISCHARGE APPROACH

MEE : MULTI EFFECT EVAPORATOR

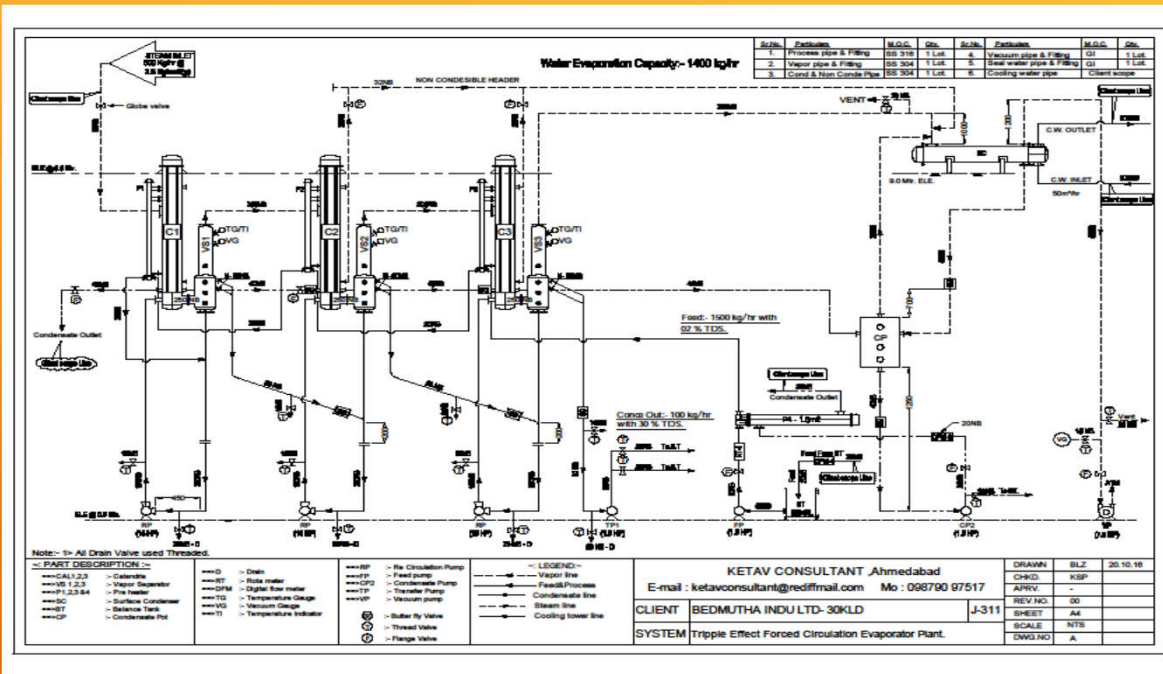

QUALITY ASSURED



EHS APPROACH: Health Checkup for ALL

▶ EHS (BIL Plant-6), have taken various steps towards plant, machine and man safety, given as –

- ✓ Work permit
- ✓ Safety Signage's
- ✓ Emergency Door
- ✓ First aid box
- ✓ RO Water for drinking
- ✓ HIRA

**ENVIRONMENT
HEALTH
SAFETY**



QUALITY ASSURED



EHS APPROACH: PLANTATION 2000 TREES



BEDMUTHA INDUSTRIES LIMITED

ENVIRONMENT
HEALTH
SAFETY



QUALITY ASSURED



BEDMUTHA INDUSTRIES LIMITED

EHS APPROACH: 100% PLANTATION PLAN ADHERANCE

ENVIRONMENT



**EHS APPROACH: 100% PLANTATION PLAN
ADHERENCE**



Tree Plantation for the year 2017-18

Sr. No.	Total Factory area (in Hectors) [In case of local body total area]	Total nos. of tree planted up to 31.03.2017	Total Nos. of trees survived so far	Target of the tree plantation in the year 2017-18	Avenue plantation/Road side plantation to be carried out in 2017-18	Rain water harvesting program done in 2016-17 with details	Rain water harvesting program proposed in 2017-18 with details	Corporate social responsibility (CSR) undertaken last year: its details with expenditure	Corporate social responsibility (CSR) proposed in year 2017-18 & its details with expenditure
1	2	3	4	5	6	7	8	9	10
1	52.0 Acres	3200	2950	2000	200	-	-	-	-



QUALITY ASSURED



EHS APPROACH: BLOOD DONATION CAMP / FIRE FIGHTING TRAINING / MOCK DRILLS / FIRST AID / PLANTATION



QUALITY APPROVED

EXPORT

- => GERMANY
 - => NETHERLAND
 - => USA
 - => DENMARK
 - => FRANCE
 - => AUSTRIA
 - => POLAND
 - => ITALY
 - => BELGIUM
 - => DUBAI
- 



**PRODUCT BRANDING
EXHIBITION PARTICIPATION**



QUALITY ASSURED

WIRE & CABLE,
DUSSELDORF,
GERMANY 2014

WIRE & CABLE,
MUMBAI, INDIA
2014

WIRE & CABLE,
DUSSELDORF,
GERMANY 2016

WIRE & CABLE,
MUMBAI, INDIA
2016

ELEVATORS,
AHMADABAD,
MAY 2017, INDIA

KRISHI/FARMING
, NASIK, INDIA
2017

ELEVATORS,
COIMBATOOR,
AUG 2017, INDIA



IMPORTANT MEETS:



QUALITY ASSURED



IMPORTANT VISITS: CUSTOMERS / DEALERS



QUALITY ASSURED

IMPORTANT TRAININGS:



COMMANDO
Wines & Wine Products

SUP
SPECIALIZED
ULTRA SPECIAL

BG
BEDMUTHA
GROUP

QUALITY ASSURED

EHS APPROACH: LNG

ENVIRONMENT
HEALTH
SAFETY



GOVERNMENT OF INDIA
MINISTRY OF COMMERCE & INDUSTRY
PETROLEUM AND EXPLOSIVES SAFETY ORGANISATION (PESO)
WEST CIRCLE

Tel: 27575946, 27573881
 Fax: 22-27575947
 Email: jccemumbai@explosives.gov.in

A1 & A2 wing, 5th Floor,
 C.G.O. complex, CBD Belapur,
 Navi Mumbai (M.S.)-400614

L.C. No. : SHOMH/03/1777 (851655) Date : 23 Feb. 2016
 To, 22 MAR 2016
 M/s. Bedmutha Industries Limited,
 E-1, MIDC Nardana, Phase II, Waghadhi Khurd,
 Taluk Shindkheda,
 Chhat District : DHULE,
 State : Maharashtra

Sub: Storage of LNG, gas in pressure vessels at Village E-1, MIDC Nardana Phase II, Waghadhi Khurd
 Taluk Shindkheda-Dist: DHULE, State: Maharashtra L.C. No. SHOMH/03/1777 (851655)
 Renewal Granted under SMP(VI) Rules, 1981

Sir/s,
 Reference: Your letter No. SIG/EXP dated: 8/2/2016
 Licence Number: SHOMH/03/1777 is renewed and is valid upto to 31/03/2019 is forwarded herewith.
 The provisions of the Rule 55 of the above said rules shall be followed for further renewal of the licence beyond 31/03/2019. The renewal application along with fees, Original licence and other documents shall reach in the Office of West Circle, Mumbai latest by 2nd March, 2019 positively to avoid late fees.
 Please acknowledge the receipt of the licence.

Yours faithfully,

 Controller of Explosives
 for J. Chief Controller of Explosives West Circle
 West Circle, Navi Mumbai (M.S.)

GOVERNMENT OF INDIA
MINISTRY OF COMMERCE & INDUSTRY
PETROLEUM AND EXPLOSIVES SAFETY ORGANISATION (PESO)
WEST CIRCLE

Form III
 (See Rules 49 and 50)
Licence to Store Compressed gas in pressure vessel or vessels

Licence Number : SHOMH/03/1777 (851655) Fee Rs : 10000/-

Licence is hereby granted to M/s. Bedmutha Industries Limited E-1, MIDC Nardana, Phase II, Waghadhi Khurd Taluk Shindkheda-Dist: DHULE, State: Maharashtra valid only for the storage of compressed gas in 1 Number of pressure vessels as indicated below in the licensed premises described below and shown in the plan No. SHOMH/03/1777 dated 11 June, 2013 subject to the provisions of the Indian Explosives Act, 1984 (A of 1984) and the rules made thereunder and to the further conditions of this licence.

Vessel No.	Name of Gas	Gas- State	Water Capacity in cubic M	Max working Prc. (kg/cm ²)	Quantity Granted in kgs (Liquified gases)
0011211751	LNG	Liquified	191.67	10	44332
Total Water Capacity			191.67		

The licence shall remain in force upto 31st day of March, 2014.

The 11, June, 2013.  Chief Controller of Explosives

DESCRIPTION AND LOCATION OF THE LICENSED PREMISES
 The licensed premises, the layout boundaries and other particulars of which are shown in the attached approved plan No. SHOMH/03/1777 dated 11 June, 2013 and consists of 1 vessel for storage of :
 a) Flammable/Corrosive/Toxic Gases: LNG
 b) Non-toxic Gases :

SPACE FOR ENDORSEMENT OF RENEWALS

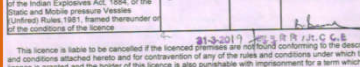
Date of renewal	Date of expiry	Signature and stamp of the licensing authority
11-3-2019	31-3-2019	

This licence shall be renewable without any concession in fee for three years in the absence of contravention of the provision of the Indian Explosives Act, 1984, or the Licenced Rules, 1981, framed thereunder or of the conditions of the licence.

This licence is liable to be cancelled if the licensed premises are not found conforming to the description and conditions attached hereto and for contravention of any of the rules and conditions under which this licence is granted and the holder of this licence is also punishable with imprisonment for a term which may extend to two years or with fine which may extend to three thousand rupees or with both.

QUALITY ASSURED



EHS APPROACH: NITROGEN PLANT

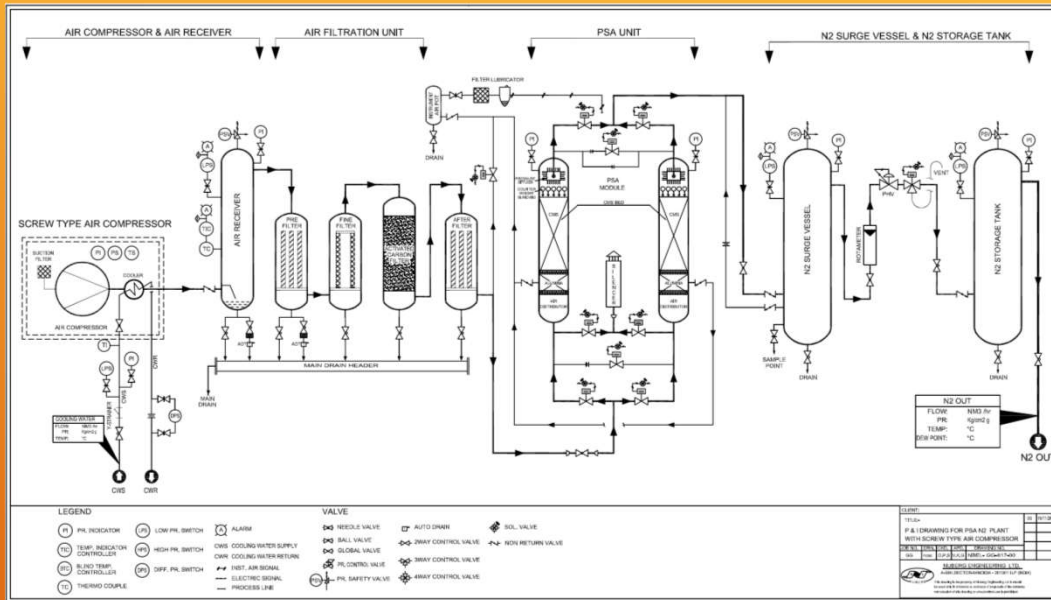

COMMANDO
Wires & Wire Products

SUR
-wire ropes-

APPROVED
LR

swachh bharat

TUV NORD
TUV India Private Ltd.
ISO 9001 / 14001 / BS OHSAS 18001

BG
BEDMUTHA GROUP

QUALITY ASSURED

BEDMUTHA INDUSTRIES LIMITED

BEDMUTHA INDUSTRIES LIMITED

OUR CUSTOMERS

A large grid of logos for various companies, including Interkabel, Hendrik Veder Group, Santhi Funi, Reliance Jio Infocomm, Larsen & Toubro, Gabaswire, JWC, Jumbo Wire & Cable Co. Ltd., Sterlite, jsk, GALAXY, Jainex Group, JDS GROUP, HINDUSTHAN URBAN INFRASTRUCTURE LIMITED, IBEX, GALLAGHER, usha martin, BWR, UNICOB, Uniflex Cables Ltd., FinOptic, Suprajit, INDORE, MACCAFERRI, LEONI, PHOENIX, Cabion Technologies, GOMA PROTECT PVT. LTD., MET global protection Industries, Astratech Steels, A-1 FENCI, Apollo screens, BILFINGER, WATER TECHNOLOGIES, FLSMIDTH, DBIND WIRE PRODUCTS PVT. LTD., Supreme, TECHFAB INDIA, KISHORE FARM EQUIPMENTS PVT. LTD., Laxmi Wire Products, Panchsheel ENTERPRISES, AAHIL FENCE PRODUCTS, GREEN STAR, SUPREME EQUIPMENTS PVT. LTD., STELLAR, Sheela Group, Nilkamal, Kurl-on, Peps INDUSTRIES PVT. LTD., Restolex rise & shine, AS, PAWAN ENTERPRISES, Vishal WIRES & CABLES, Repose making better beds, duroflex mattresses, Centuary India ka Sleep Specialist, skyfoam, RADCOFLEX INDIA PVT. LTD., U TECH Your Reliable Partner, U TECH FASTEN PVT. LTD., Apt Technologies, METPLAST, Maimoon Razor Wire, Kataria, SP ENGINEERING, BSY, Crescent Steel & Allied Products Ltd., APPROVED R, and TUV NORD certifications.

COMMANDO
Wires & Wire Products
sur
- wire ropes -

QUALITY ASSURED





Govt Registrations



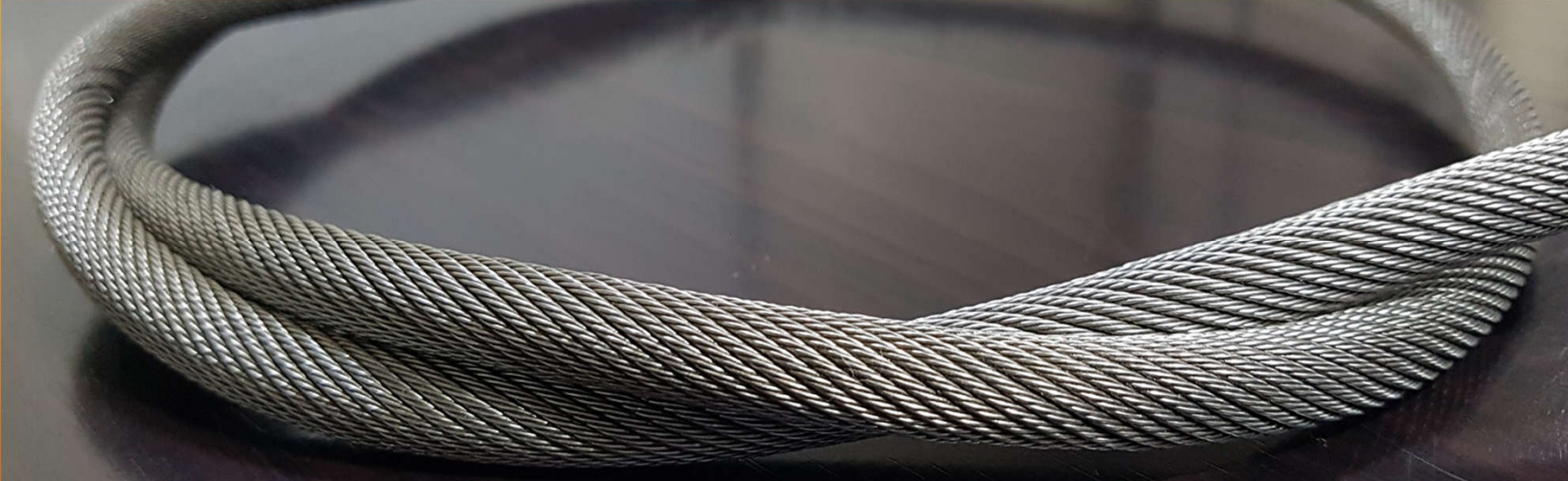

**BEDMUTHA
GROUP**

THANK YOU

